



RUBBER METAL

Anti vibration mounts
AMC MECANOCAUCHO®

MORE THAN 55 YEARS OF EXPERIENCE ENDORSE US

Since 1969 **AMC MECANOCAUCHO®** has pioneered the manufacture and design of articles for the reduction of integral vibrations from structures and air-borne noise.





24 h.

48 h.

72 h.

San Sebastián
Asteasu



Our stock is at your service.

VIBRATION ISOLATION GRAPH

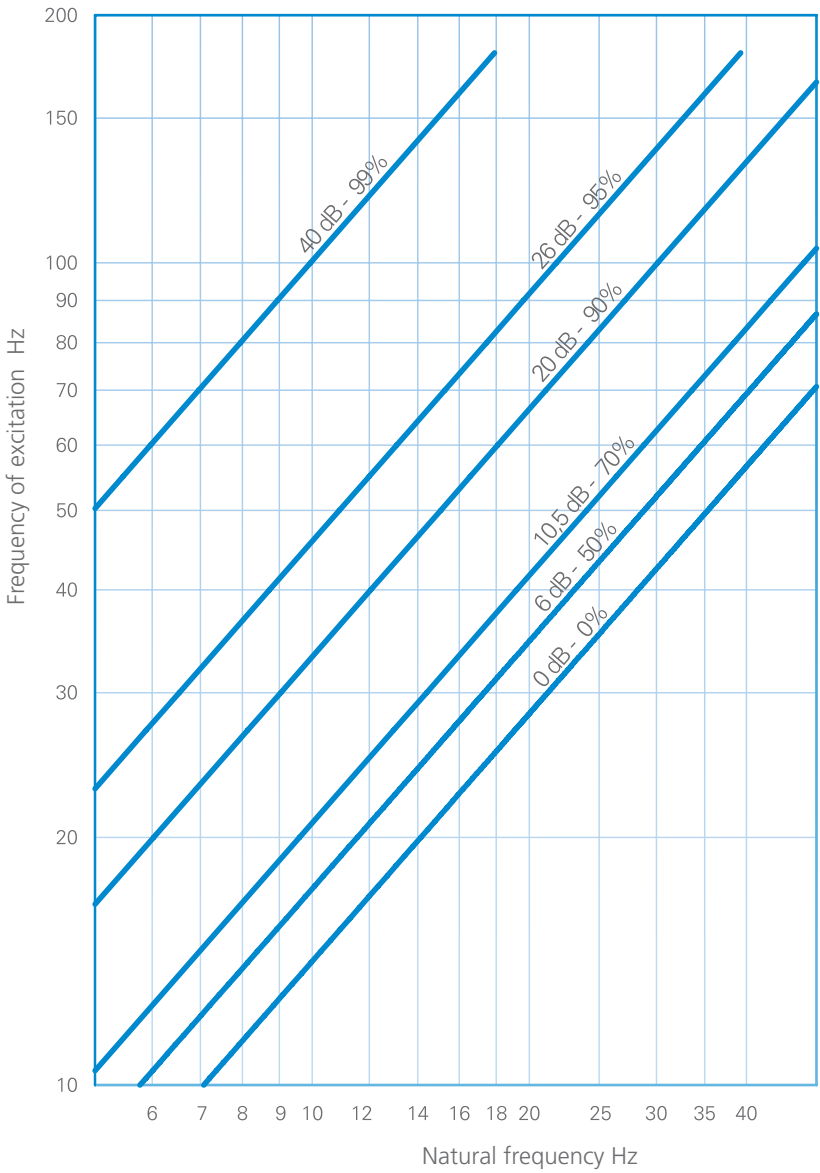

QUALITY COMMITMENT

The products commercialised by AMC are all made in-house.

The stiffness and levels of adhesion of all these products have been controlled so that they may be identified as "AMC MECANOCAUCHO®" products, whereby they can be traced. AMC MECANOCAUCHO® is officially approved by the NATO under the ID no. NCAGE 0230 B-compliant supplier.

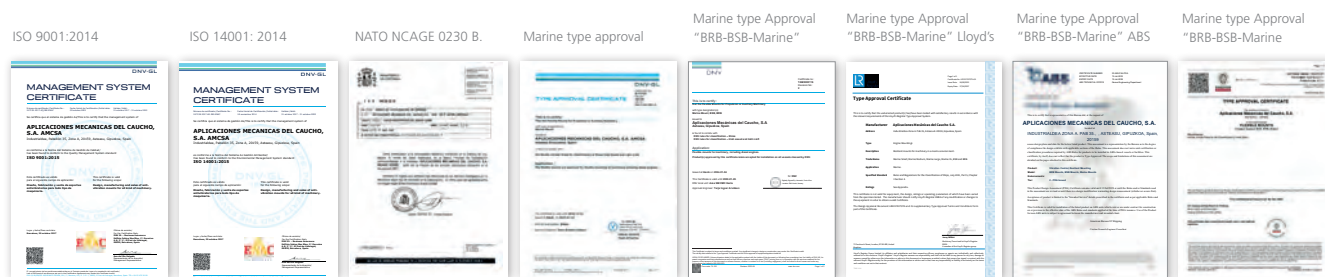

Adhesion Test

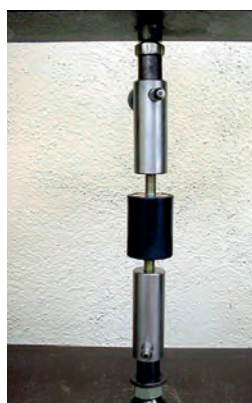

Extensometer

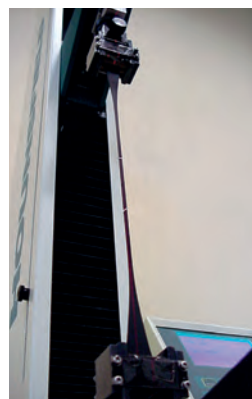

Rheometer

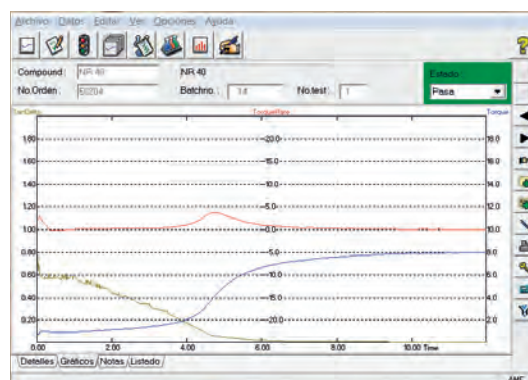
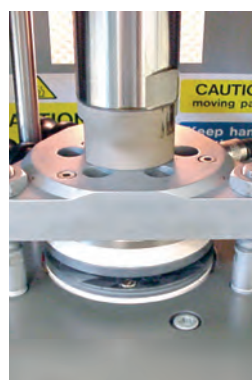
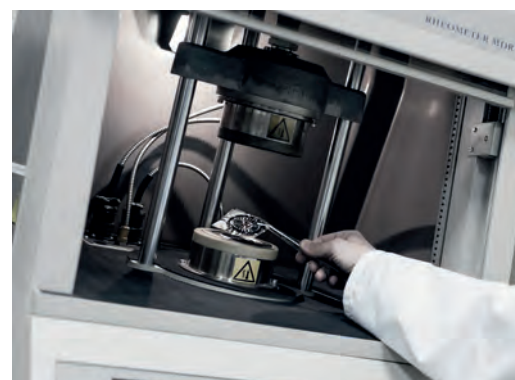

THE SOLUTION

Machinery, which by virtue of its design has reciprocating or rotating parts, creates vibration to some degree through imbalance of the moving parts.

This vibration produced by a machine leads to different problems, such as a reduction in the machine's useful life through part wear, plus the transmission of this vibration to other non-insulated adjacent structures, giving rise to problems of noise and vibration transmission.

FFT analysis of orders for a diesel engine

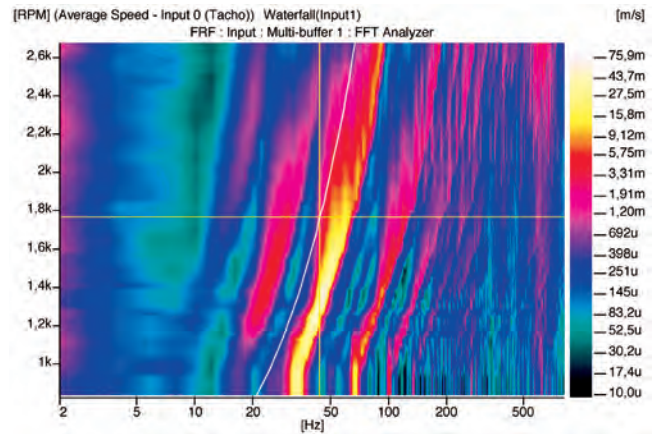

For more than 45 years, AMC MECANOCAUCHO® has been developing the "AMC MECANOCAUCHO®" range of rubber-metal anti-vibration supports which can solve problems like the ones described above in all types of machinery, mobile or static, thus protecting people and the environment from the harmful effects of noise and vibrations.

Engine FFT

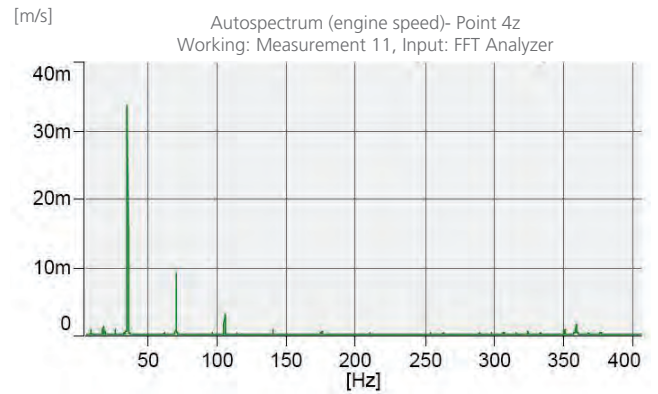

Chassis FFT

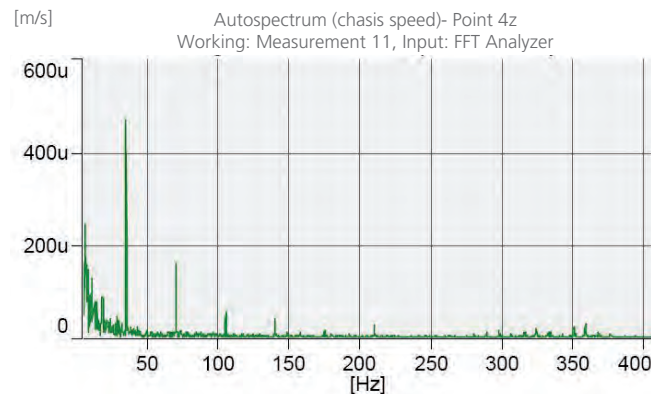

APPLICATIONS

Our products are used in sectors such as:

- Generation of electrical energy
- Air compression
- Pumping of liquids
- Industrial vehicles
- Machine Tools
- Marine propulsion and auxiliary equipment
- Agricultural and construction equipment machinery
- Acoustic isolation of premises and sites
- Vibrating screens, Hoppers, Silos, Feeder screens

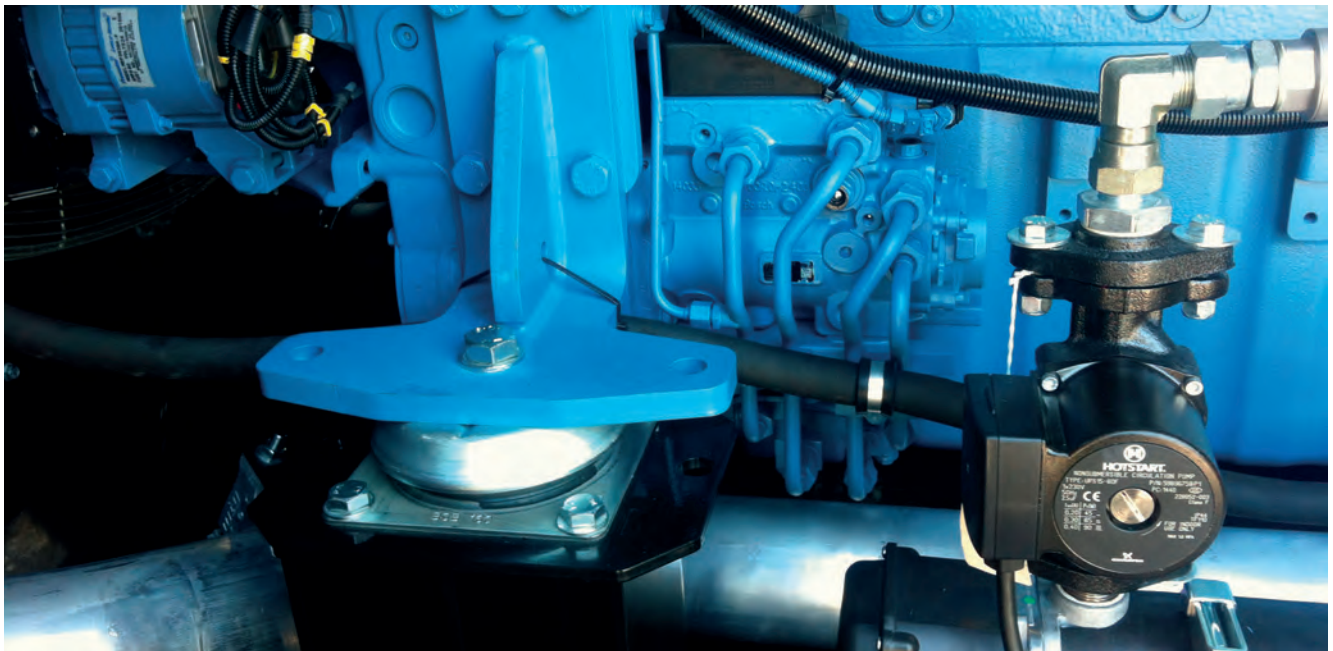

2. Design

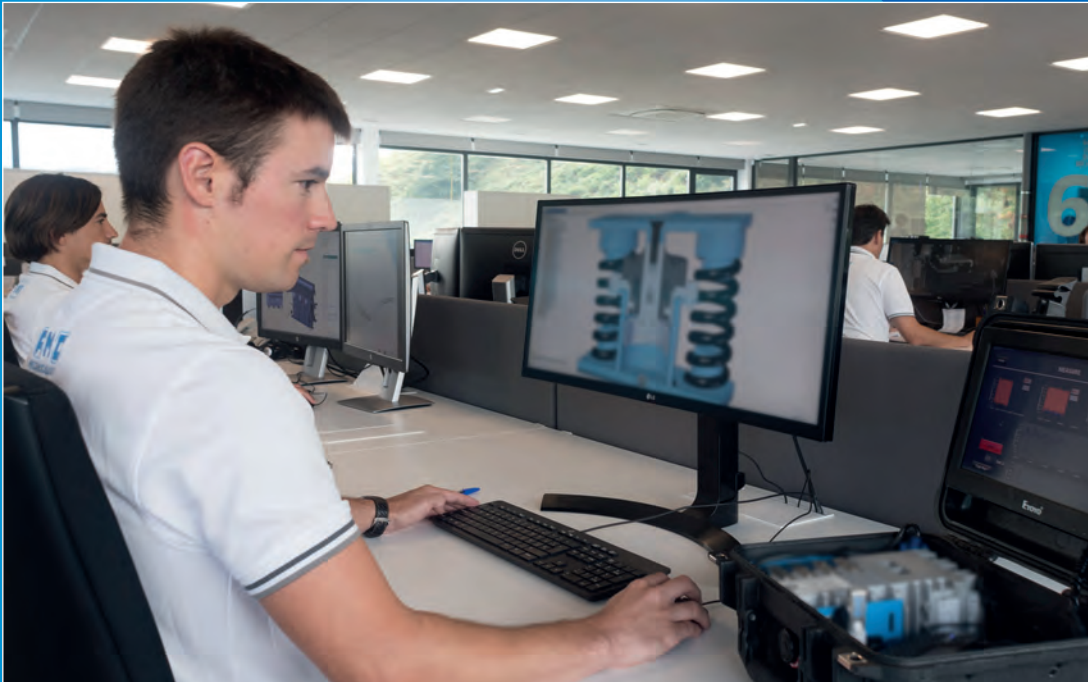

After studying client specific needs for the application and the isolation performance required, **AMC MECANOCAUCHO®** can produce a new design if standard products are not suitable.

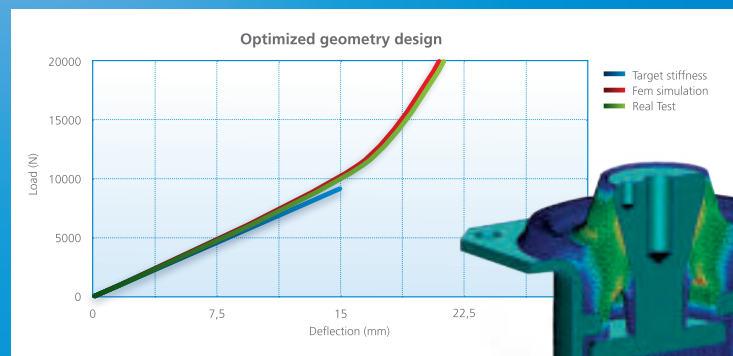

Stress analysis by nonlinear FEM.

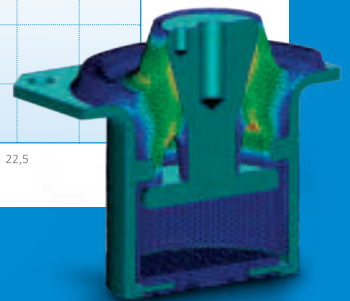

FEM Simulation

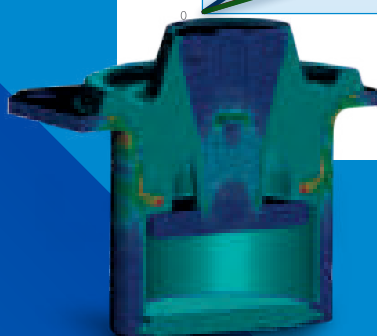
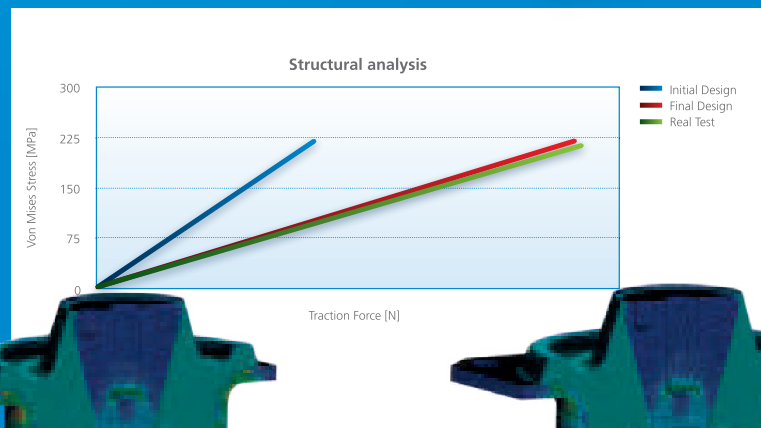

Initial concept



Final Concept

3. Test and dynamic characterisation

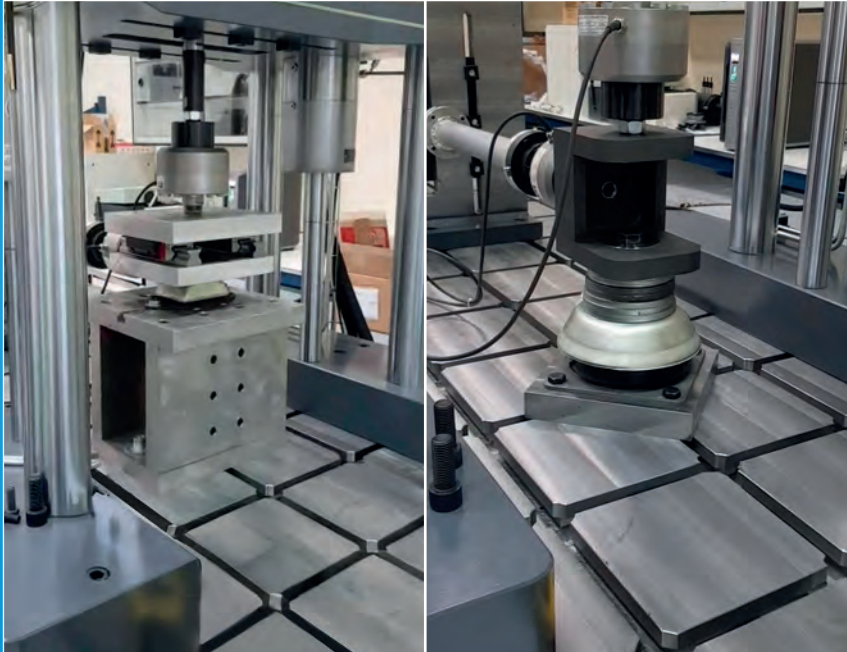

AMC MECANOCAUCHO® can offer customers a wealth of experience and know how in measuring noise and vibration to effect optimun solutions to those problems.

4. Measurements



AMC MECANOCAUCHO® provides its customers with all its experience and know-how in measuring vibrations and noise in the field so as to reduce machine-produced emissions of noise and vibrations.



ANTI-VIBRATION TECHNIQUES

1.-ABC AT A GLANCE

MASS SPRING SYSTEM

A mass spring system may be represented by a mass "M", excited by a force "F" and supported on an elastic stiffness element "K" with a damping factor "C".

The frequency of the mass spring system is equal to:

$$f_o = \frac{1}{2 \cdot \pi} \sqrt{\frac{k}{M}}$$

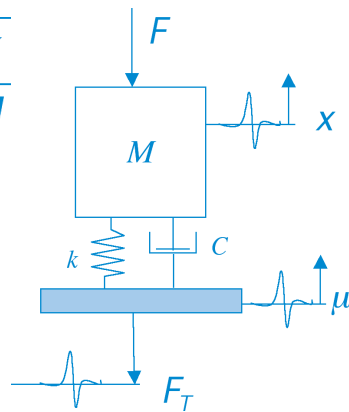

figure 3

- K (N/m)
- M (kg)
- F_o (Hz)
- C (Ns/m)

The effectiveness of the suspension may be measured by transmissibility, i.e. by the force which is transmitted by the machine to the ground or floor. It is defined as the ratio between the force transmitted to the ground, F_{OT}, and the original force produced by the vibration F_o.

Another practical term is often used to describe the efficacy of an anti-vibration mount, namely the degree of insulation, which is:

$$\text{Transmissibility equation: } E = (1 - T) \times 100\%$$

Taking the following parameters into account:

Excitation

$$x = x_o \sin(\omega t + \vartheta)$$

$$F = F_{T_o} \sin(\omega t + \vartheta)$$

Response

$$\mu = \mu_o \sin \omega t$$

$$F = F_o \sin \omega t$$

Own Pulsation: $\omega_o = \sqrt{\frac{k}{M}}$ $C \cong 0$

and natural frequency of $f_o = \frac{1}{2 \cdot \pi} \sqrt{\frac{k}{M}}$

The damping parameters are: $C_c = 2 \cdot \sqrt{kM}$

Where C_c is the critical damping and ξ

the damping coefficient. $\xi = \frac{C}{C_c}$

For this system we obtain a transmissibility T and a magnification factor A:

$$T = \frac{x_o}{\mu_o} = \frac{F_{T_o}}{F_o} = \sqrt{\frac{1 + \left(2 \cdot \xi \cdot \frac{\omega}{\omega_o}\right)^2}{\left(1 - \frac{\omega^2}{\omega_o^2}\right)^2 + \left(2 \cdot \xi \cdot \frac{\omega}{\omega_o}\right)^2}}$$

For the case of active $T = \frac{F_{T_o}}{F_o}$ and

passive isolations, we will have to $T = \frac{x_o}{\mu_o}$

Figure 5 represents the transmissibility curve of the schematic mass spring system of figure 3.

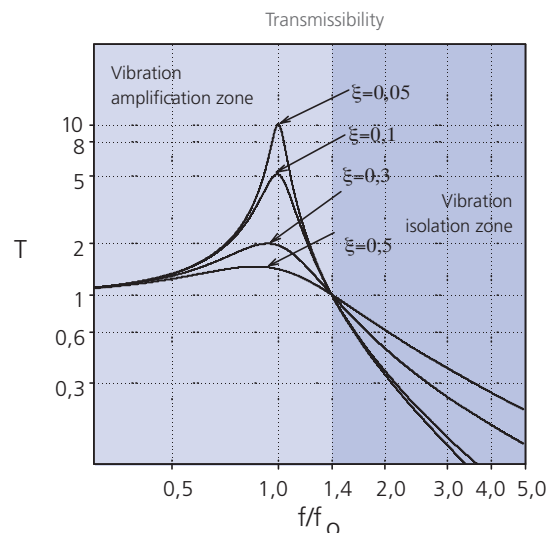

Examining this curve allows us to reach basic conclusions for an effective isolation.

If the frequency of excitation is $\sqrt{2}$ times less the natural frequency, transmissibility is greater than one, then the force transmitted is greater than the excitation force, there is magnification of the vibrations. When we work in this area, the existing damping in the system is important. The greater the latter, the smaller the magnification of the vibrations will be.

If the frequency of excitation is $\sqrt{2}$ times greater than the natural frequency, transmissibility is less than one, or in other words the force transmitted is less than the force originated in the system, then we are in the damping area.

In order to achieve the greatest isolation, the lowest possible natural frequencies should be sought. There are two ways of doing this:

- By increasing the system mass.
- By reducing the stiffness of the anti-vibration mount.

To increase the efficacy of the isolation in the damping area, it is advisable to have low damping, although weak damping generates greater displacement when passing through the resonance, it is advisable to use a damping coefficient T so that passage through the resonance does not give rise to inadmissible displacement for the machine.

STATIC AND DYNAMIC STIFFNESS

The stiffness of a rubber anti-vibration mount changes when a dynamic force is applied to it. This parameter depends on architecture, the compound used and even the frequency of excitation.

Generally speaking, dynamic stiffness is always greater than static stiffness, so calculations based on static stiffness may lead to wrong conclusions. In some cases it is possible to reach limits of dynamic stiffness which are two and even three times greater than the static stiffnesses.

DAMPING

The damping coefficient depends basically on the compound used in manufacturing of the anti-vibration mount. It is a crucial parameter that must be addressed when designing anti-vibration suspensions.

CREEPING AND LONG-TERM BEHAVIOUR

If an elastomeric element is under a static load, this load produces a progressive increase in deformation.

This phenomenon may be important in a wide variety of applications, from mounts for buildings to engine mounts.

Creeping at a given time t is calculated as:

$$t = \frac{x_1 - x_0}{x_0} \times 100\%$$

And is expressed as a percentage (%) of the initial deformation. This value depends on the geometry of the mount, and above all on the way the rubber is worked.

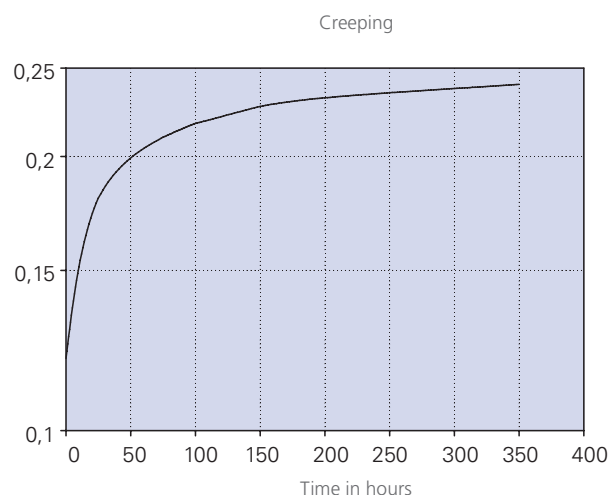

Designs that use rubber in shear are more conducive to "Creep" than designs which use rubber in compression or shear and compression.

ANTI-VIBRATION TECHNIQUES

1.-DYNAMIC TESTING MACHINE

Dynamic stiffness can only be established by measurement on a dynamic test bench. Similarly, the damping coefficients of compounds are further values that can be measured with this type of machines.

One concept that must be taken into account when designing an anti-vibration mount is its durability. A dynamic testing machine allows us to conduct fatigue tests that reproduce the real working conditions of the part so that its useful life can thus be predicted accurately.

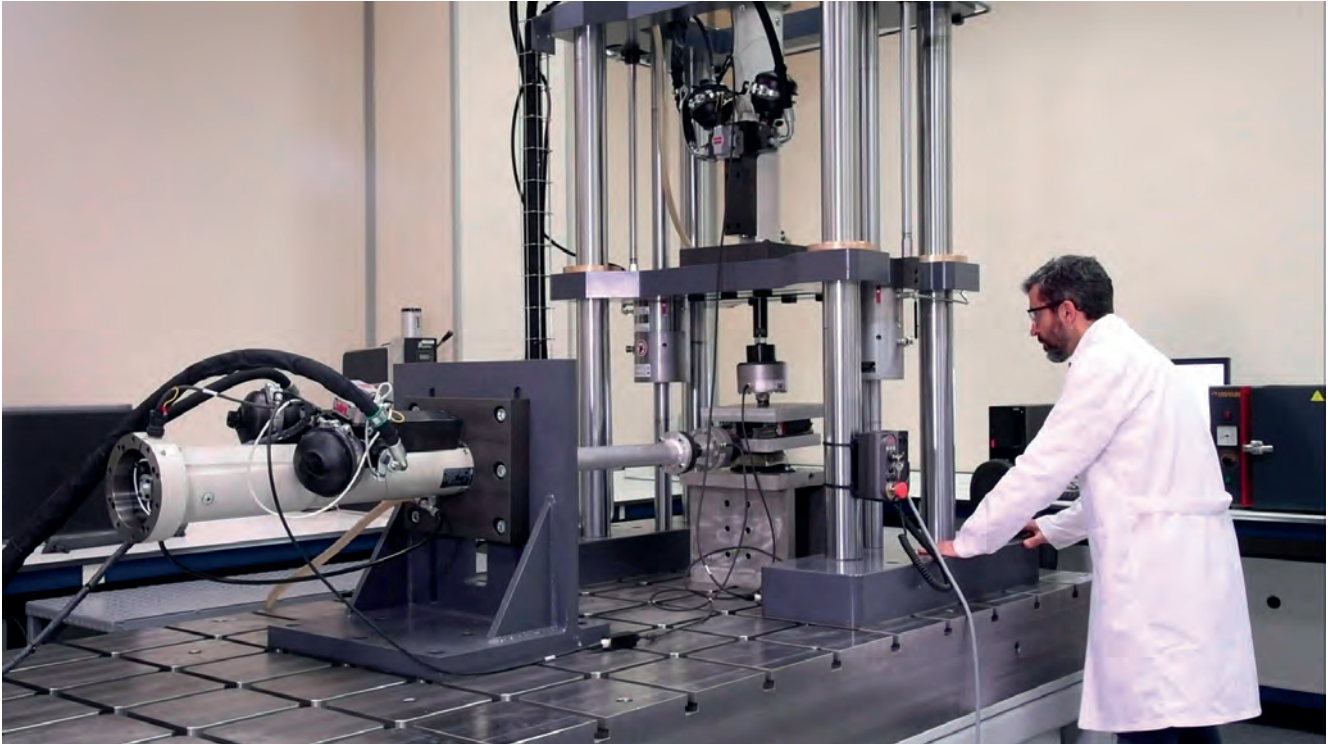

2.- ANALYSIS OF SYSTEMS OF MORE THAN ONE DEGREE OF FREEDOM

In actual fact, there are cases where the model of 1 degree of freedom cannot correctly define the behaviour of the equipment to be isolated. In such cases AMC MECANOCAUCHO® have analysis tools that enable more elaborate models to be made taking into account the 6 Degrees of Freedom rules.

The latest computing tools can also generate virtual models of solid rigid multiples and study how they interact with each other and with the environment.

As a result, we can ascertain the natural frequencies of the system which are really important to prevent them from coinciding with the excitation frequencies so as not to have resonance problems.

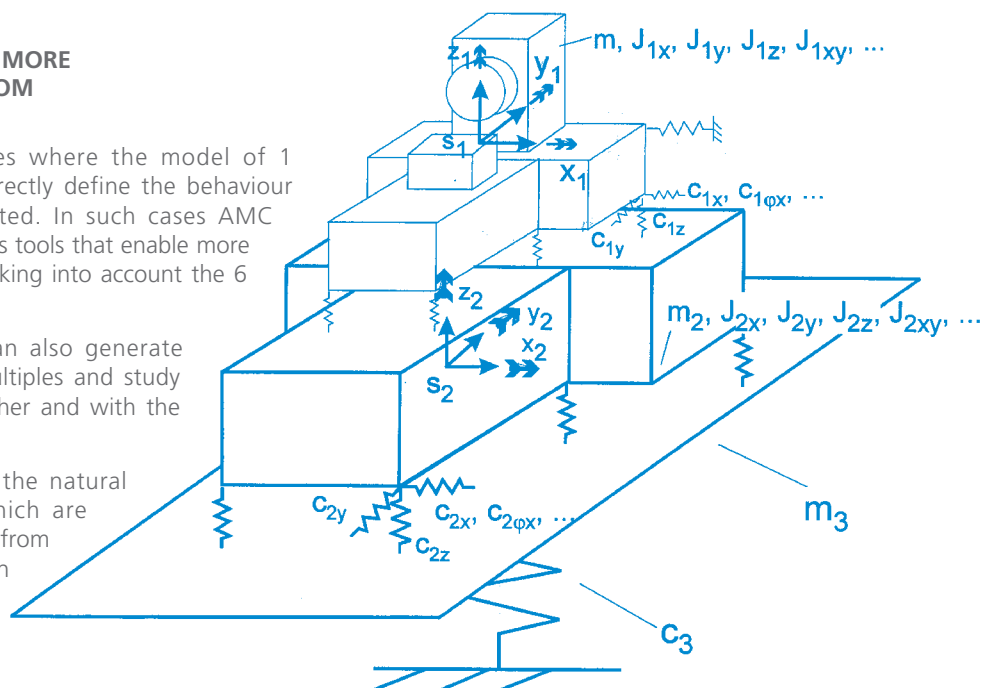

GENERAL CHARACTERISTICS OF ELASTOMERS



NATURAL RUBBER

Natural rubber is used in the manufacture of elastomers with high elasticity and tear strength. It is a strong material with excellent abrasion resistance. Among all the rubber families, natural rubber offers the best resistance to mechanical and dynamic loads. Natural rubber is not stable versus non-polar liquids such as mineral oils, lubricants, fuels and aliphatic and aromatic and hydrocarbons and chlorides. Its moderate ozone stability can be improved with additives.



OZONE RESISTANCE

This characteristic is important for measuring an elastomer's weather stability. The speed at which it may deteriorate depends on the prevailing environment conditions and the formulation of the compound.

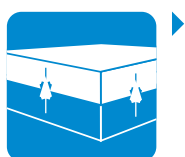

ADHESION

The bond between elastomers and metals is made by adhesives which are applied to the metal parts which leverage the process of vulcanisation to create a firm bond between elastomer and metal.



SYNTHETIC RUBBERS

Synthetic rubbers are conceived using raw materials such as petroleum or natural gas. At the moment they have found their own fields of application where natural rubber does not meet the required technical specifications, such as heat resistance (silicones and EPDM), oils (nitrils) or weather (neoprene).



CREEPING AND PERMANENT DEFORMATION

The creeping and permanent deformation of elastomers subjected to continuous stress is unavoidable. The material presents a creep which in the case of permanent deformation is expressed as a percentage of the static load. Values of of 25% are usual in anti-vibration mounts.



COMPOUNDS

An elastomer is not composed of a single material, but rather contains very varied substances. Mixes can be made with different formulations to obtain different stabilities and different mechanical characteristics.

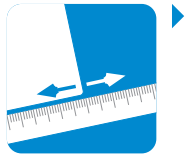

TOLERANCES

No part can be manufactured with absolute precision, the dimensional tolerances of rubber articles are established in the ISO 3302 standard. As for physical properties, hardness may vary by ± 5 shore, and stiffness "K" admits a margin of $\pm 20\%$. In cases of highly demanding requirements, this margin can be reduced to $\pm 10\%$ thanks to a highly-sophisticated process.



HARDNESS

The hardness of the elastomer depends on its formulation and is measured by means of practical units established by different standards such as shore (A) or IRH. AMC Mecanocaucho uses the shore scale (A), and manufactures anti-vibration mounts with hardnesses of between 40 and 75 shore.

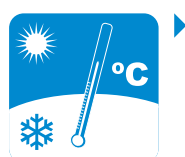

THERMAL STABILITY

Natural rubber based vulcanised materials are stable within the limits of -40°C to $+80^{\circ}\text{C}$, if the action of the temperature in question is permanent.

If the temperature acts sporadically, these elastomers can act from -50°C to $+120^{\circ}\text{C}$, although these limits may be varied by using specific formulations.

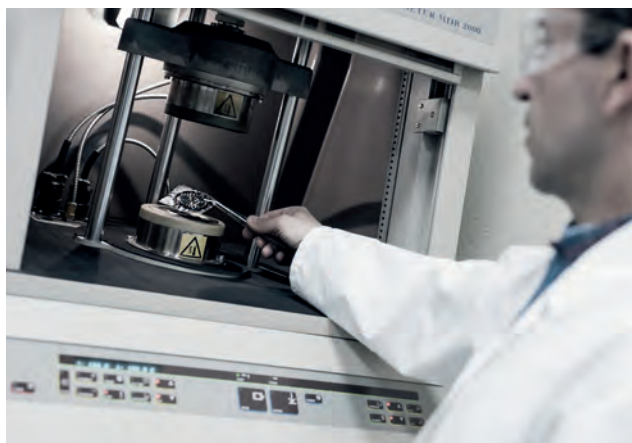

VIBRATION ISOLATION EFFICIENCY GRAPH

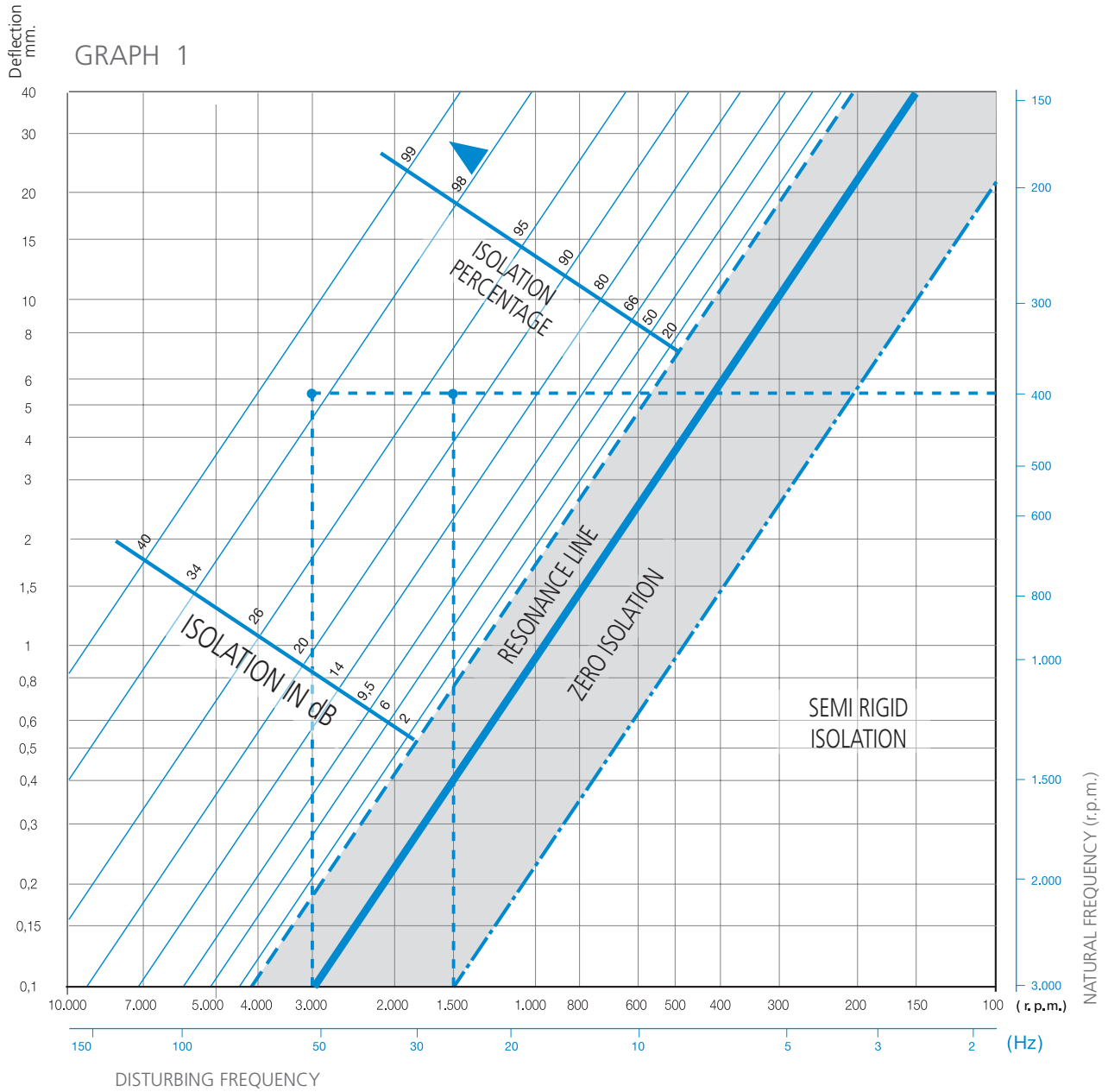

INDEX DEPENDING ON THE APPLICATION

MOBILE APPLICATIONS: ENGINES, GENERATORS, COMPRESSOR PUMPS

 BRB Page 16	 BSB Page 18	 BRBX Page 20	 BRT Page 21	 MD Page 22	 MARINE MOUNTS Page 24	 MARINE X MOUNT Page 25	 MARINE MOUNTS TYPE XD Page 26	 MARINE MOUNTS TYPE XT Page 27
 HYDRAULIC MOUNTS Page 28	 HYDRAULIC CONES Page 34	 CONES Page 38	 DSM Page 46	 CONES WITH FIXATION FLANGE Page 48	 CABIN MOUNTS Page 50	 CB Page 52	 TF Page 54	 SCH Page 56
 SCHR Page 58	 SCB Page 60	 SCBR Page 62	 VD Page 63	 MARINE V-TYPE Page 64	 AN 60 Page 66	 NP MOUNTS Page 68	 SN Page 69	 TFS Page 69
 AT Page 70	 SPS Page 72	 AKUSTIK PIPE / OMEGA Page 73	 WF Page 74	 FZ SYLOMER® Page 76	 SFC, SFT, ST Page 78	 WIRE ROPE ANTI VIBRATION MOUNT Page 79	 HELICAL WIRE ROPE SOLUTION Page 80	 FZM Page 81
 SVT Page 82								







STATIC APPLICATIONS: ENGINES, GENERATORS, HYDRAULIC PUMPS AND COMPRESSORS

 GENERATOR MOUNT IN V Page 83	 DRD Page 84	 DSD Page 86	 ATP Page 88	 TRANSFORMER MOUNTS Page 89	 ELASTOMERIC SPRINGS Page 90	 REINFORCED ELASTOMERIC SPRINGS Page 91
---	---	---	---	---	---	--

BUSHINGS

 ECCENTRIC BUSHINGS Page 92	 BUSHINGS Page 94
---	--

MOUNTS FOR HEAVY LOADS

 SANDWICH Page 95	 SH Page 96	 ANTI-SKID Page 98	 TYPE B Page 98	 TYPE P Page 98	 ANTI-SKID P Page 98	 TYPE S Page 98
--	--	---	---	--	---	--

MACHINE LEVELLING MOUNTS

 NF-NFR Page 100	 SV Page 101	 SV LOW Page 102
---	---	---

ELASTIC COUPLINGS

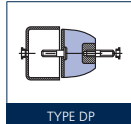
 COUPLING Page 103	 TYPE DP Page 103
---	---

RUBBER BLOCKS AND MATS

 TYPE T Page 104	 TYPE C Page 104	 300X300 Page 104	 400X400 Page 104	 BLOCKS Page 104
---	---	--	--	---

BOBBINS & BUFFERS

 STUD MOUNTS Page 106	 RUBBER BUFFERS Page 114
---	---

OTHERS

 HEIGHT ADJUSTERS Page 116

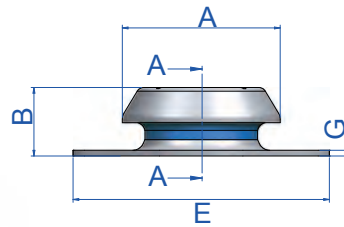

BRB 50
BRB 60
BRB 65
BRB 70
BRB 80
BRB 85
BRB 95
BRB 110
BRB 125
BRB 150

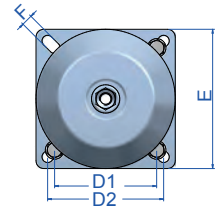
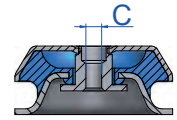
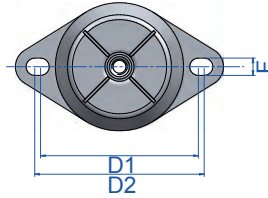

BRB 150 S.B.
BRB 180
BRB 220

BRB

DESCRIPTION

The BRB type AMC MECANOCAUCHO® mounts are antivibration elements which work the rubber in shear and compression. Their tall height section produce large deflections, low natural frequencies, and excellent vibration isolation results. This range of mounts is suitable for applications where high vibration isolation in the 85-95% range is a priority.

TECHNICAL CHARACTERISTICS

- The top metal hood protects the rubber from the Ozone, UV rays, diesel or oils which damage the rubber.
- The metal parts have a suitable anticorrosive treatment for outdoor applications. RoHs compliant.
- They have an interlocking metal component that provides a fail-safe protection for mobile applications. This device limits the ascending vertical movement when the mounting is submitted to shocks at traction.
- The mounts are clearly identified, as the base-plates are engraved with the type and hardness, which makes it possible to easily recognise the part even after several years of use.
- The hood has a cross stamped on the top, which enhances its rigidity on mobile applications and also improves the evacuation of oils or liquids that precipitate onto it.

APPLICATIONS

This mount is suitable for the isolation of mobile rotating machines which are exposed to axial and radial shocks, dripping oil, diesel or exposure to the weather. It is particularly interesting for applications where a high level of vibration isolation is required.

MARINE CERTIFICATES

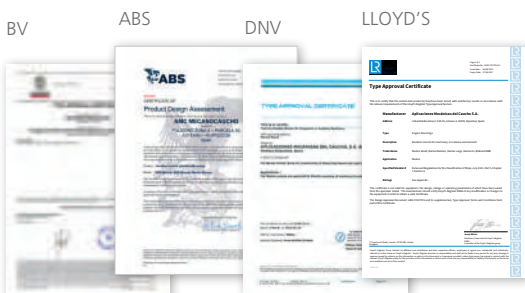

S.B. = Square Base

Type	A (mm)	B (mm)	C (mm)	D1 (Min.)	D2 (Max.)	E (mm)	F (mm)	G (mm)	Weight (gr.)	Code	Load (kg)	Shore
BRB 45	50	32	M-8	61	70	85	6,5	2	131	135137	12	40 Sh
										135138	18	50 Sh
										135139	25	60 Sh
BRB 50	50	25	M-8	61	70	85	6,5	2	117	135451	20	40 Sh
										135453	40	50 Sh
										135455	60	60 Sh
										135457	80	70 Sh
BRB 60	64	35	M-10	76,5	90,5	110	9	2,5	225	135101	30	40 Sh
										135405	45	50 Sh
										135103	65	60 Sh
										135104	75	70 Sh
										135421	50	40 Sh
BRB 65 M10	64	35	M-10	76,5	90,5	110	9	2,5	243	135422	75	50 Sh
										135423	120	60 Sh
										135424	140	70 Sh
										135431	50	40 Sh
BRB 65 M12	64	35	M-12	76,5	90,5	110	9	2,5	243	135432	75	50 Sh
										135433	120	60 Sh
										135434	140	70 Sh
										135251	50	40 Sh
BRB 70	64	35	M-12	100	100	120	11	3	253	135252	75	50 Sh
										135253	120	60 Sh
										135254	140	70 Sh
										135231	80	40 Sh
BRB 80 M10	83	35	M-10	108	112	135	11	3	398	135232	130	50 Sh
										135233	175	60 Sh
										135234	235	70 Sh
										135275	80	40 Sh
										135276	130	50 Sh
BRB 80 M12	83	35	M-12	108	112	135	11	3	398	135277	175	60 Sh
										135278	235	70 Sh
										135771	150	40 Sh
										135772	260	50 Sh
BRB 95 M10	92	39	M-10	122	126,6	150	10	3	657	135773	330	60 Sh
										135774	390	70 Sh
										135761	150	40 Sh
										135762	260	50 Sh
BRB 95 M12	92	39	M-12	122	126,6	150	10	3	657	135763	330	60 Sh
										135764	390	70 Sh
										135241	200	40 Sh
										135242	305	50 Sh
BRB 110 M12	106	41	M-12	137	149	175	13	3	857	135243	420	60 Sh
										135244	450	70 Sh
										135331	200	40 Sh
										135332	305	50 Sh
BRB 110 M16	106	41	M-16	137	149	175	13	3	857	135333	420	60 Sh
										135334	450	70 Sh
										135618	350	40 Sh
										135620	500	50 Sh
BRB 125	123	48	M-16	154	162	190	14	4	1170	135622	700	60 Sh
										135624	900	70 Sh
										135205	450	40 Sh
										135206	570	50 Sh
BRB 150 S.B.	156	53,5	M-16	125	132	164	14,5	4	2030	135207	800	60 Sh
										135208	1000	70 Sh
										135161	450	40 Sh
										135162	570	50 Sh
BRB 150	156	53,5	M-16	176	188	218	14,5	4	1840	135163	800	60 Sh
										135164	1000	70 Sh
										135391	875	40 Sh
										135392	1200	50 Sh
BRB 180	186	84	M-20	146	150	181	14	5	3800	135393	1700	60 Sh
										135394	2400	70 Sh
										135201	1600	40 Sh
										135200	2400	50 Sh
BRB 220	230	105	M-24	180	180	220	19	6	6716	135202	3400	60 Sh
										135203	4200	70 Sh
										135204	4200	70 Sh

NATURAL FREQUENCY
AMC MECANOCAUCHO® BRB 45-95

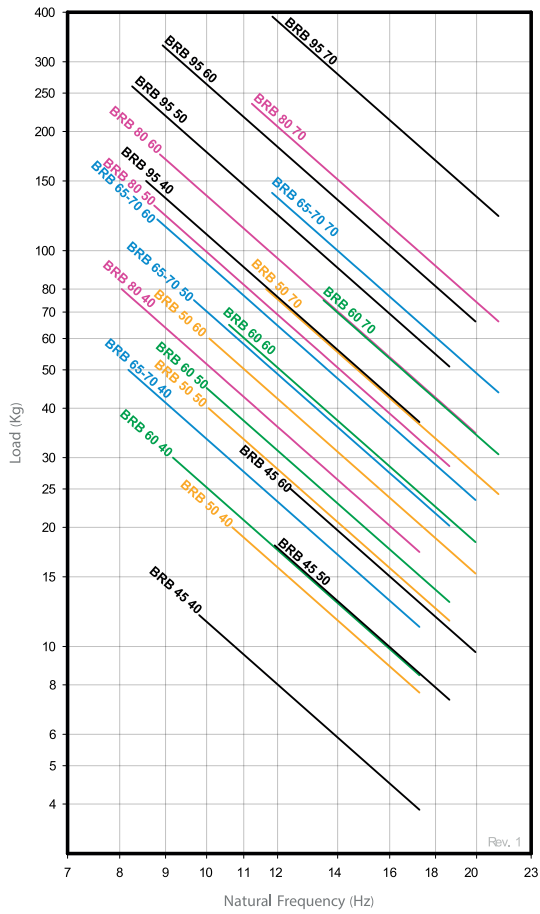

LOAD DEFLECTION GRAPH
AMC MECANOCAUCHO® BRB 45-95

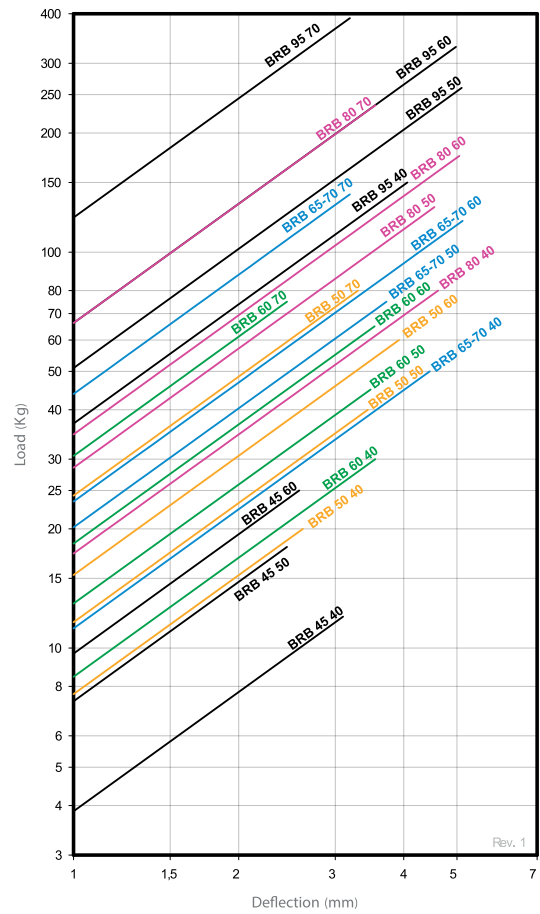

NATURAL FREQUENCY
AMC MECANOCAUCHO® BRB 110-220

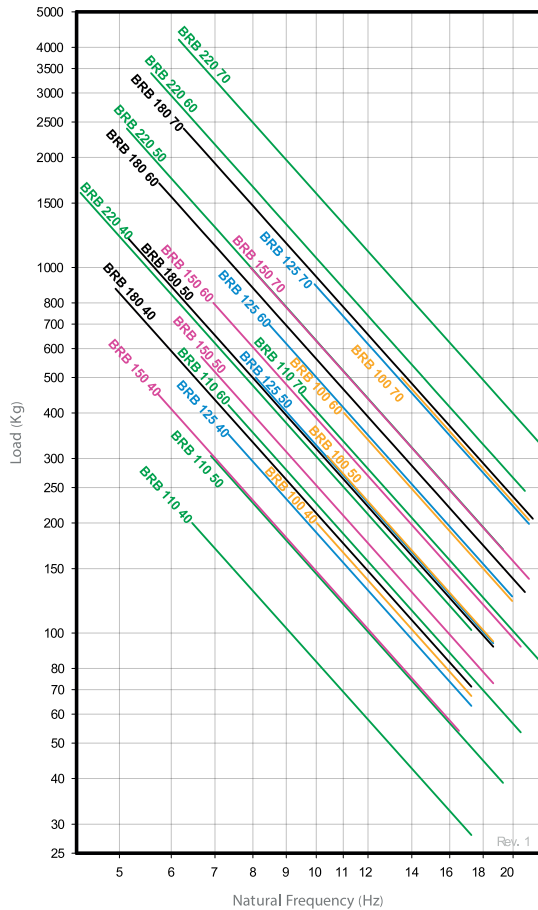

LOAD DEFLECTION GRAPH
AMC MECANOCAUCHO® BRB 110-220

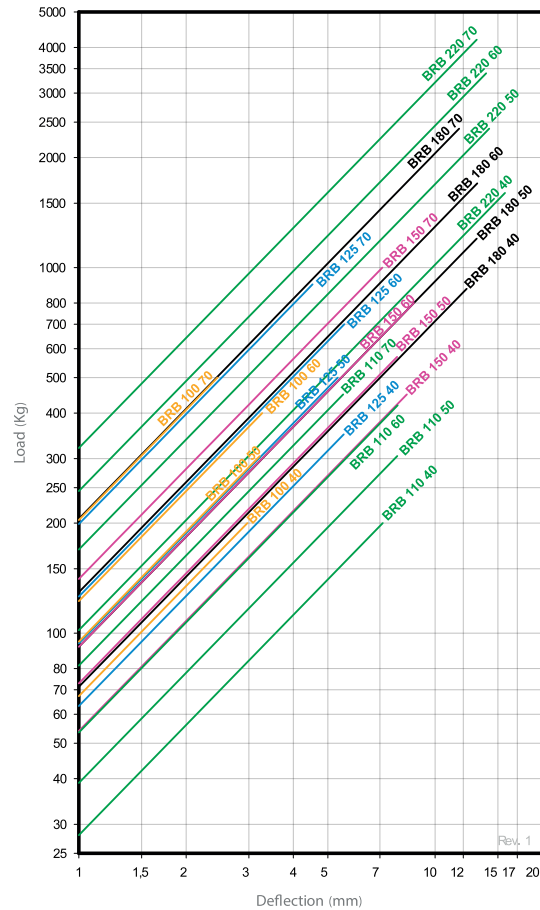



BSB

DESCRIPTION

The BSB type AMC MECANOCAUCHO® mounts are antivibration elements which work the rubber in shear and compression with an optimal ratio of stiffness and horizontal stability. These mounts are really interesting when stability is a priority in an antivibration suspension.

In applications where the degree of isolation is a priority, we must choose the BRB-type range of AMC MECANOCAUCHO® antivibration mounts.

TECHNICAL CHARACTERISTICS

- The top metal hood protects the rubber from the Ozone, UV rays, diesel or oils which may cause major damage to the rubber.
- The metal parts have a suitable anticorrosive treatment for outdoor applications. RoHs compliant.
- They have an interlocking metal component that provides a fail-safe protection for mobile applications. This device limits the ascending vertical movement when the mounting is submitted to shocks at traction.
- The mounts are clearly identified, as the baseplates are engraved with the type and hardness, which makes it possible to easily recognise the part even after several years of use.
- The hood has a cross stamped on the top, which enhances its stiffness on mobile applications and also improves the evacuation of oils or liquids that splash onto it.

APPLICATIONS

In mobile rotating machines that require control of movements and reasonable values of vibrations and noise, such as:

Pumps, Marine-Land auxiliary units, Industrial Vehicles, Compressors, Ventilators...

This mount is suitable for the isolation of mobile rotating machines which are exposed to axial and radial shocks, dripping oil or diesel or exposure to the weather.



Type	A (mm)	B (mm)	C (mm)	D1 (Min.)	D2 (Max.)	E (mm)	F (mm)	G (mm)	Weight (gr.)	Code	Load (kg)	Shore
BSB 60	64	34	M-10	76,5	90,5	110	9	2,5	235	135106	70	40 Sh
										135109	130	50 Sh
										135107	170	60 Sh
										135108	245	70 Sh
BSB 80 M10	78	31	M-10	108,2	111,2	130	9,2	3	355	135261	110	40 Sh
										135262	160	50 Sh
										135263	230	60 Sh
										135264	300	70 Sh
BSB 80 M12	78	31	M-12	108,2	111,2	130	9,2	3	351	135265	110	40 Sh
										135266	160	50 Sh
										135267	230	60 Sh
										135268	300	70 Sh
BSB 95 M10	92	34	M-10	122	126,4	150	10	3	488	135311	180	40 Sh
										135312	230	50 Sh
										135313	270	60 Sh
										135314	330	70 Sh
BSB 95 M12	92	34	M-12	122	126,4	150	10	3	488	135315	180	40 Sh
										135316	230	50 Sh
										135317	270	60 Sh
										135318	330	70 Sh
BSB 110 M12	106	37	M-12	137	150	175	13	3	785	135335	250	40 Sh
										135336	350	50 Sh
										135337	450	60 Sh
										135338	550	70 Sh
BSB 110 M16	106	37	M-16	137	150	175	13	3	785	135150	250	40 Sh
										135151	350	50 Sh
										135152	450	60 Sh
										135153	550	70 Sh
BSB 125	123	43	M-16	154	162	190	14	4	1109	135351	450	40 Sh
										135352	550	50 Sh
										135353	690	60 Sh
										135354	900	70 Sh
BSB 150 S.B.	156	49	M-16	125	132	164	14,5	4	2060	135371	750	40 Sh
										135372	950	50 Sh
										135373	1300	60 Sh
										135374	1650	70 Sh
BSB 150	156	49	M-16	176	188	218	14,5	4	1818	135361	750	40 Sh
										135362	950	50 Sh
										135363	1300	60 Sh
										135364	1650	70 Sh
BSB 160	156	57	M-20	140	140	170	14,5	4	2200	135381	900	40 Sh
										135382	1200	50 Sh
										135383	1600	60 Sh
										135384	2300	70 Sh
BSB 180	180	67	M-20	149	163	192	14,5	4	3800	135181	1300	40 Sh
										135184	1750	50 Sh
										135182	2100	60 Sh
										135183	2900	70 Sh
BSB 220	230	105	M-24	180	180	220	19	6	6716	135301	2500	40 Sh
										135302	3200	50 Sh
										135303	4000	60 Sh
										135304	5000	70 Sh

S.B. = Square Base

MARINE CERTIFICATES

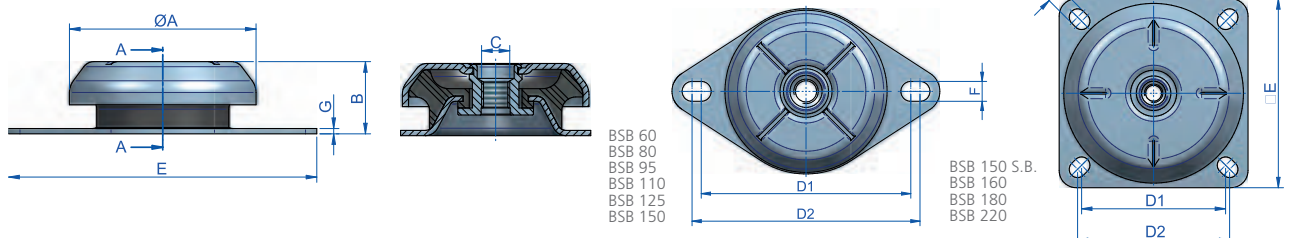
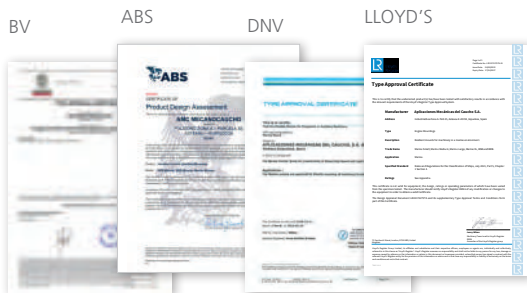

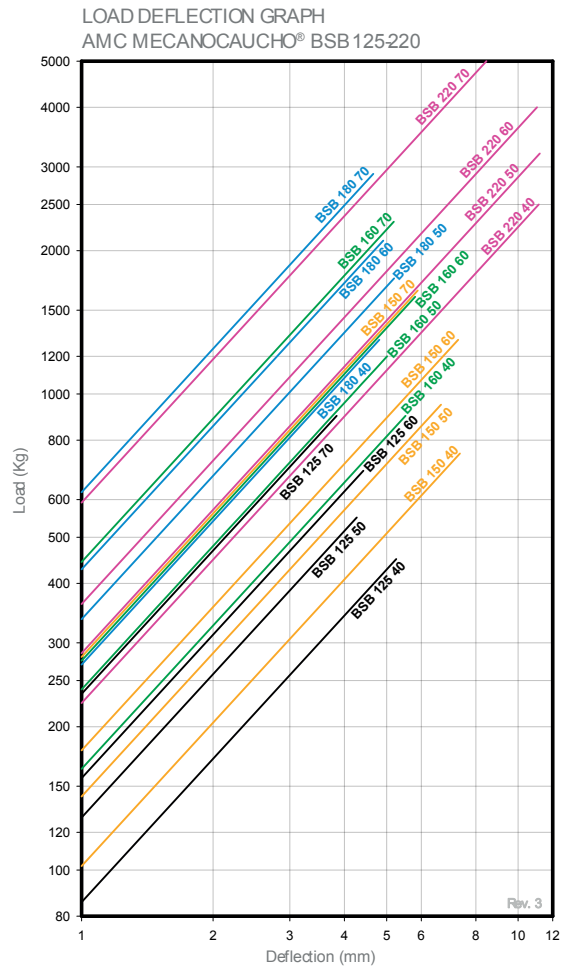
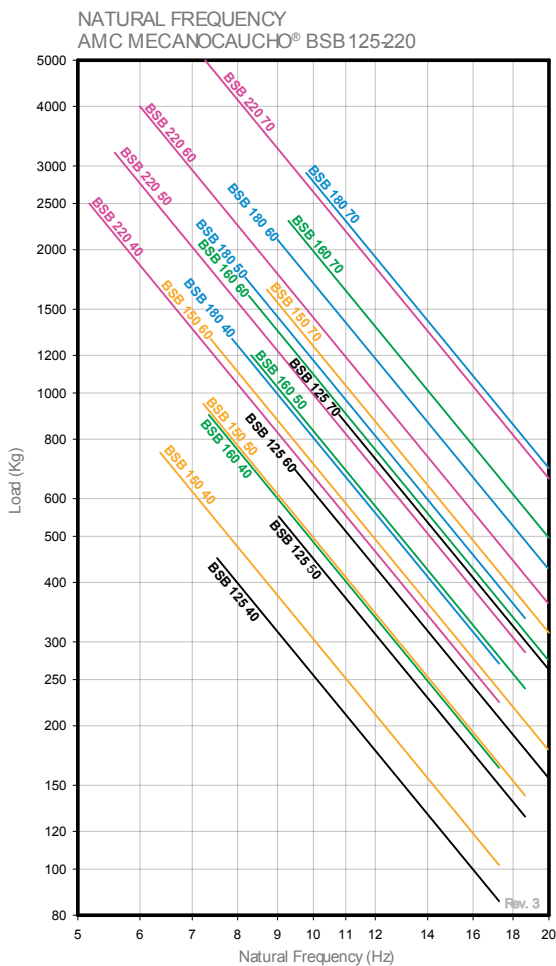
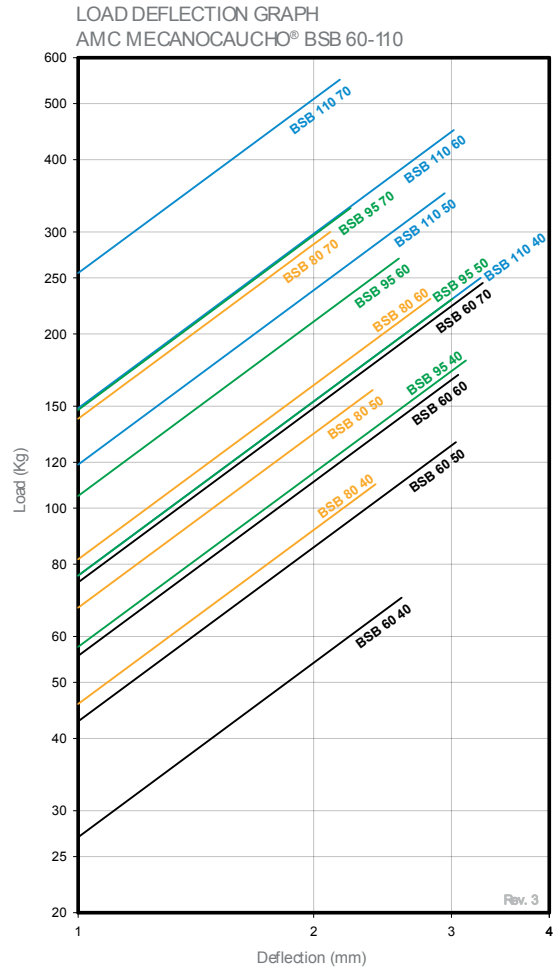
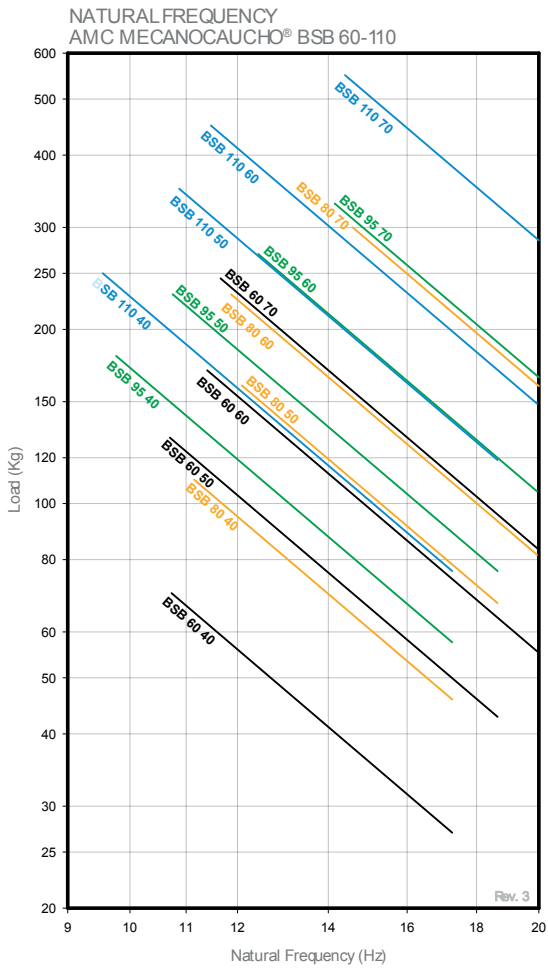

BRBX



AIISI 304

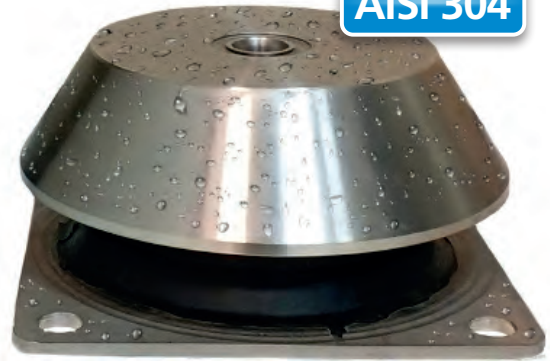

APPLICATIONS

AMC Mecanocaucho® BRBX Captive anti vibration mounts are anti vibration elements which work the rubber in shear and compression. Their high profile rubber sections produce larger deflections, low natural frequencies. This range of mounts is suitable for applications where vibration isolation is a priority.

AMC Mecanocaucho® BRBX Captive mount is especially recommended for applications where vibration isolation is necessary, such as isolation of rotating or mobile machines that are continuously subjected to shocks, dripping oil or diesel or are exposed to the elements.

LOAD DEFLECTION GRAPH
AMC MECANOCAUCHO® BRBX 50-80

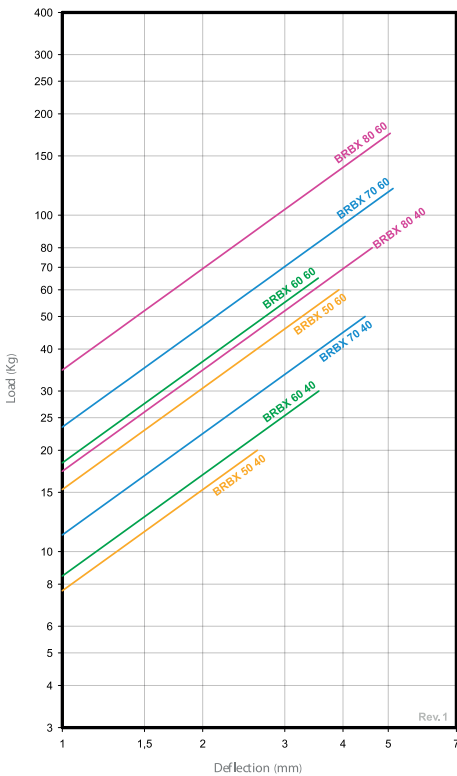

LOAD DEFLECTION GRAPH
AMC MECANOCAUCHO® BRBX 110-220

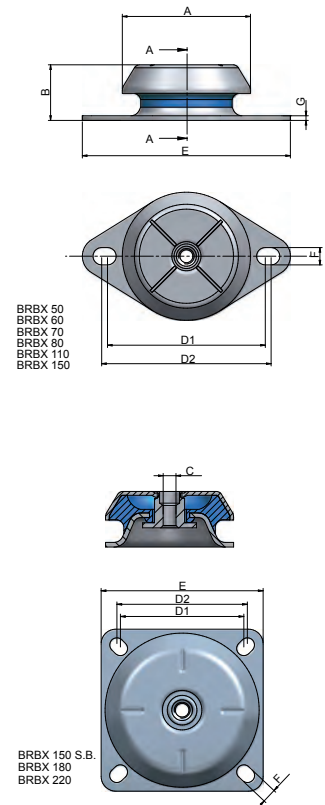
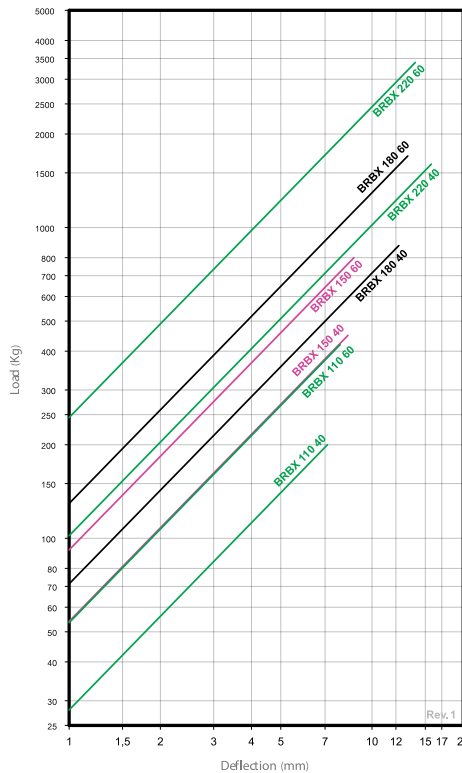

Type	A (mm)	B (mm)	C (mm)	D1 (Min.)	D2 (Max.)	E (mm)	F (mm)	G (mm)	Weight (gr.)	Load (kg)	Shore	Code
BRBX 50	50	25	M-8	61	70	85	6,5	2	117	20	40Sh	135969
										60	60Sh	135973
BRBX 60	64	35	M-10	76,5	90,5	110	9	2,5	225	30	40Sh	135687
										65	60Sh	135914
BRBX 70	64	35	M-12	100	100	120	11	3	253	50	40Sh	135935
										120	60Sh	135936
BRBX 80	83	35	M-12	108	112	135	11	3	398	80	40Sh	135956
										175	60Sh	135949
BRBX 110	106	41	M-12	137	149	175	13	3	857	200	40Sh	135735
										420	60Sh	135736
BRBX 150	156	53,5	M-16	176	188	218	14,5	4	1840	450	40Sh	135975
										800	60Sh	135984
BRBX 150 S.B.	156	53,5	M-16	125	132	164	14,5	4	2030	450	40Sh	135993
										800	60Sh	135994
BRBX 180	186	84	M-20	146	150	181	14	5	3800	875	40Sh	135396
										1700	60Sh	135466
BRBX 220	230	105	M-24	180	180	220	19	6	6716	1600	40Sh	135461
										3400	60Sh	135463

BRT



DESCRIPTION

AMC MECANOCAUCHO® BRT engine mounts are antivibration elements which work the rubber in shear and compression with an optimal ratio of stiffness and horizontal stability. These engine mounts are really applicable as stabilizers of electrical cabinets or racks. Thanks to the robust fail safe architecture it is useful in applications where the box type assembly is submitted to shocks.

TECHNICAL CHARACTERISTICS

- The top metal hood protects the rubber from the Ozone, UV rays, diesel or oils which may cause major damage to the rubber.
- The metal parts have a suitable anticorrosive treatment for outdoor applications. RoHs compliant.
- They have an interlocking metal component that provides a fail-safe protection for mobile applications. This device limits vertical movement when the mounting is submitted to shock inputs.
- The mounts are clearly identified, as the baseplates are engraved with the type and hardness, which makes it possible to easily recognise the part even after several years of use.
- The hood has a cross stamped on the top, which enhances its stiffness on mobile applications and also improves the evacuation of oils or liquids that splash onto it.

APPLICATIONS

This mount is suitable for mobile boxes or racks that require greater control of movement due to axial and radial shock inputs providing reasonable values of vibration and noise attenuation, such as:

Electrical cabinets, Pumps, Marine-Land auxiliary units, Industrial Vehicles, Compressors, Ventilators...

This mount is suitable for the isolation of mobile rotating machines which are exposed to axial and radial shocks, dripping oil or diesel or exposure to weathering.

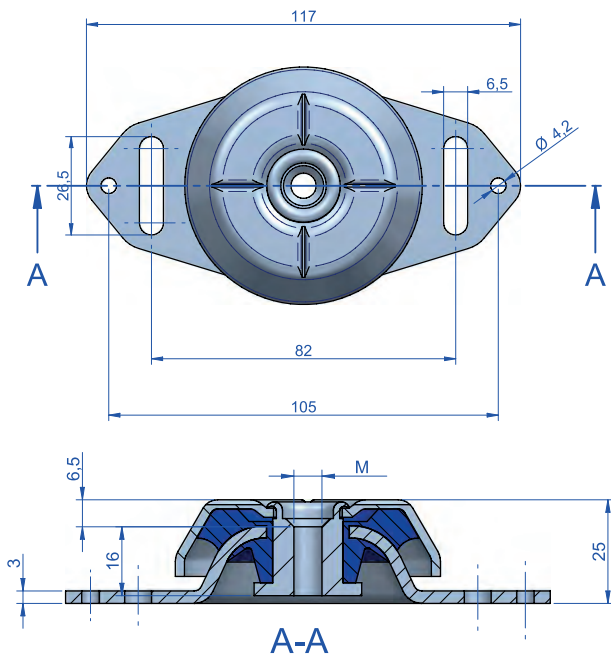

LOAD DEFLECTION GRAPH
AMC MECANOCAUCHO® BRT TYPE

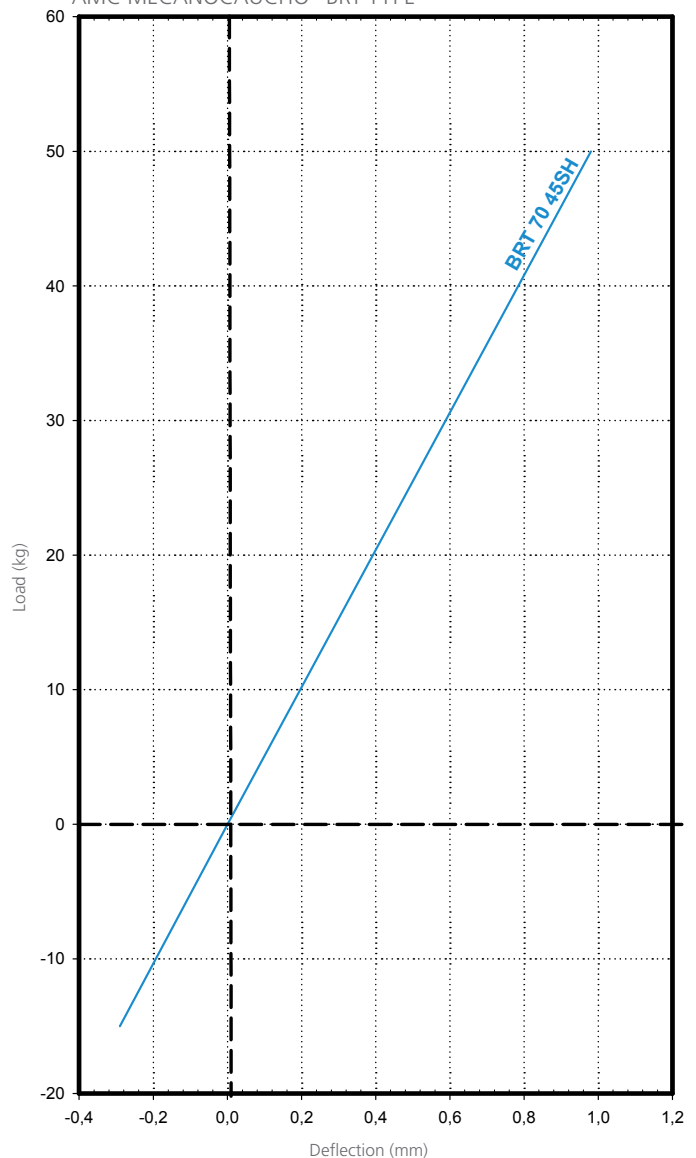

Type	Shore	Static Load max. daN	Dynamic Load max. daN	Code	M
BRT 70	45 Sh	50	150	135805	M-6
				135806	M-8
				135807	M-10

* AMC S.A. reserves the right to modify the design and manufacture of the materials presented in this catalogue without prior notice.



MD

DESCRIPTION

The AMC MECANOCAUCHO® MD-type mounts have similar architecture to the BSB and BRB. The advantage of this mount is that it is a high-damping elastic compound.

Its special mix affords it a high degree of antivibration isolation and offers great stability to suspended equipment.

TECHNICAL CHARACTERISTICS

- The top metal cap protects the rubber section from possible diesel and oil splashes.
- It has an electrolytic coating that protects the metal parts against corrosion.
- The mounts have an interlocking metal component that provides fail-safe protection for mobile applications. This device limits vertical movement when the mounts are subjected to shock loads in transit.

APPLICATIONS

This mount has been specially designed to isolate engines that produce high-amplitude vibrations.

Engines from 1 to 3 cylinders used on - Motor Pumps, Gen Sets, Compressors, Ventilators...

WHEN TO USE THEM?

The AMC MECANOCAUCHO® MD-type mount has an anti-vibration mount function but also an engine stabilizer. It is used when conventional rubber-metal mounts do not guarantee sufficient stability to the engines. The MD mount can be installed on small 1, 2 and 3 cylinder engines, which are particularly unstable.

These mounts are suitable for the suspension of machines with multiple stops and starts, and for which the passage through the resonance zone requires a high degree of damping, or which work under regimes close to the resonance frequency of the system. Diesel engines require MD mounts, especially if they have few cylinders and a large diameter because the engine then creates high amplitude vibrations which can only be corrected with increased damping.

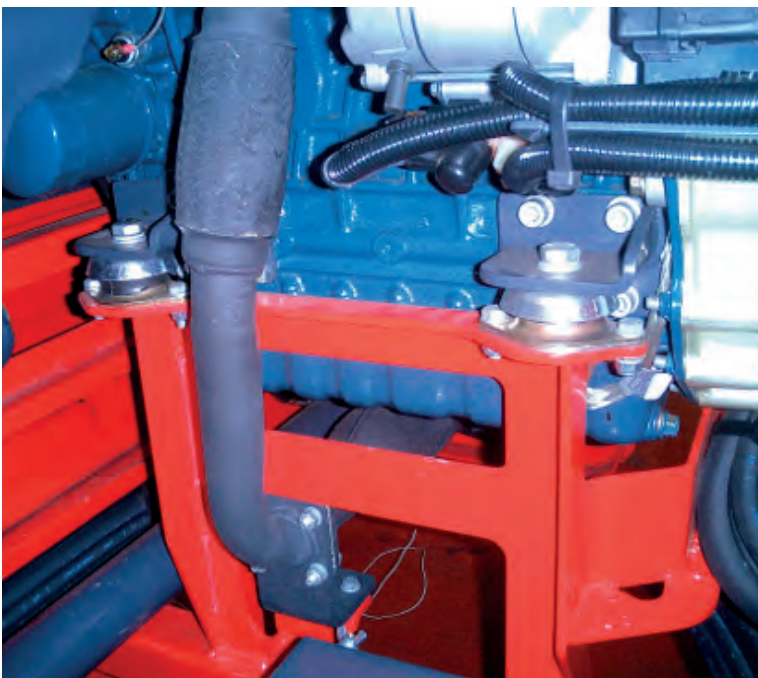

It is a very suitable mount for engines where it is not physically possible to install the antivibration mounts at the same height as the crankshaft.

VIBRATION LEVEL MEASURED IN THE ENGINE

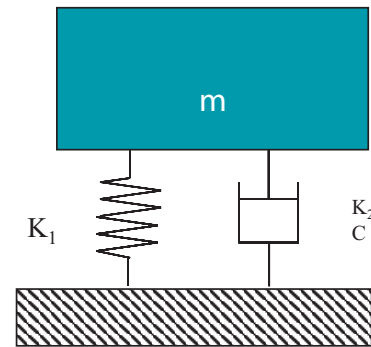
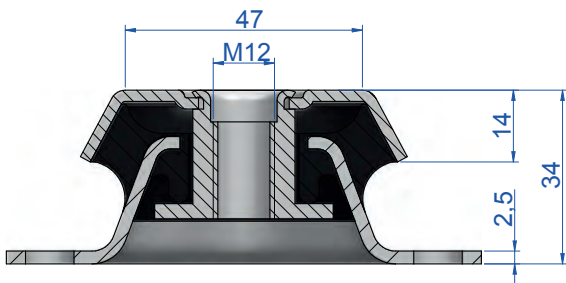
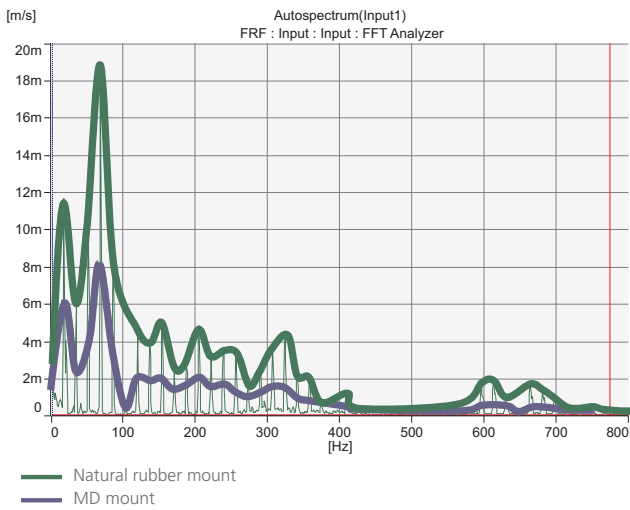

K_1 = Main stiffness - K_2 = Secondary stiffness
 C = Damping coefficient - m = Mass

LOAD DEFLECTION GRAPH
 MECANOCAUCHO® MD TYPE

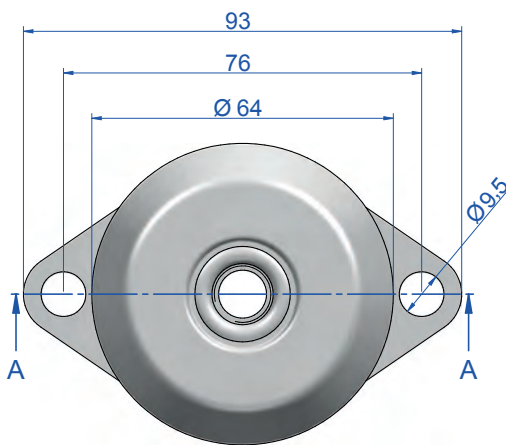
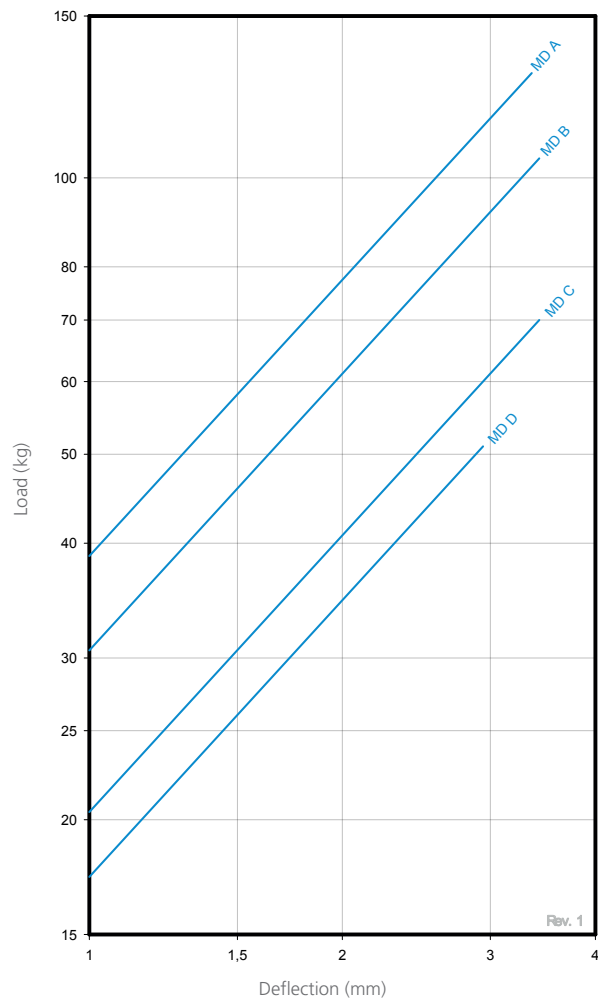

Type	Load (kg)	Weight (gr.)	Code
A	130	238	135210
B	105	238	135212
C	70	238	135213
D	50	238	135219

MARINE MOUNTS



DESCRIPTION

The Marine-type AMC MECANOCAUCHO® mounts are ideal for mobile applications thanks to their rugged architecture.

Their special design offers different stiffnesses on the three axes, they are antivibration mounts with great vertical elasticity, great longitudinal stiffness and optimal lateral stiffness to offer extra isolation on this axis.

TECHNICAL CHARACTERISTICS

- The top part of the hood has a cross-shaped stamp, which improves its stiffness in mobile applications and also improves the evacuation of oils or liquid which splash onto it.
- The metal parts have an anticorrosive treatment which is suitable for outdoor applications. RoHs compliant.
- The mounts are clearly identified, as the bases are engraved with the type and hardness.
- They have an interlocking metal component that provides a fail-safe protection for mobile applications. This device limits the ascending vertical movement when the mounting is submitted to shocks at traction.
- The top part protects the elastomer inside from possible dripping oil, diesel, ozone and ultraviolet emissions that may cause major damage to the rubber.
- The different stiffnesses for each axis make it possible to offer major flexibility in the direction perpendicular to the crankshaft/shaft of the motor. This provides more effective isolation from vibrations of all types of engines.
- For marine engine applications, contact the AMC- MECANOCAUCHO® technical department.

APPLICATIONS

In mobile rotating machines that need a major isolation capacity from vibrations and noises, such as:

- Pumps
- Marine-Land units
- Mobile electrical panels
- Industrial vehicles
- Compressors
- Ventilators
- Marine Propellers



Stiffness rates per axis.

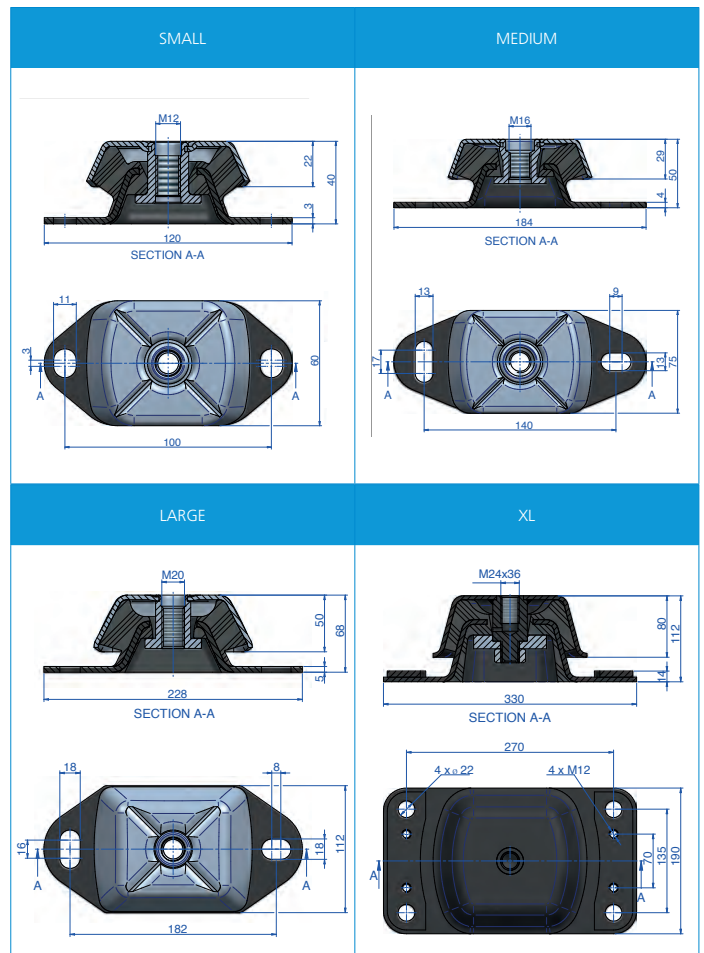
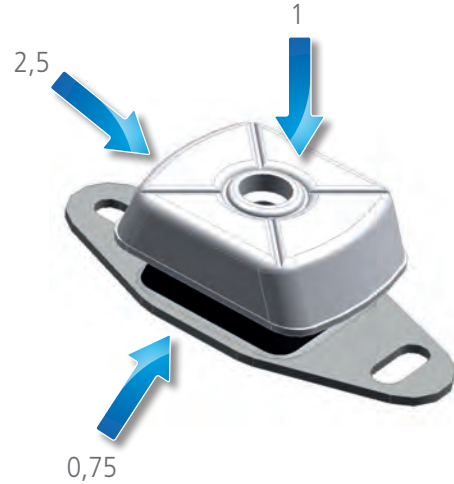

MARINE CERTIFICATES



MARINE MOUNT

Type	Weight (gr.)	Code	Load (kg)	Shore
SMALL	397	136001	35	40 Sh
		136002	45	45 Sh
		136003	70	55 Sh
		136004	95	65 Sh
		136005	110	75 Sh
MEDIUM	857	136021	95	35 Sh
		136022	120	45 Sh
		136023	220	55 Sh
		136024	280	65 Sh
		136025	400	75 Sh
LARGE	2250	136041	350	45 Sh
		136042	525	55 Sh
		136043	800	65 Sh
		136044	1080	75 Sh
XL	9600	136061	950	40 Sh
		136062	1400	50 Sh
		136063	2200	60 Sh
		136064	3000	70 Sh



MARINE X MOUNT

Type	Weight (gr.)	Code	Load (kg)	Shore
SMALL INOX	397	136216	45	45 Sh
		136220	70	55 Sh
		136217	95	65 Sh
MEDIUM INOX	857	136269	120	45 Sh
		136277	220	55 Sh
		136270	280	65 Sh

NATURAL FREQUENCY GRAPHS
AMC MECANOCAUCHO® MARINE ENGINE MOUNT

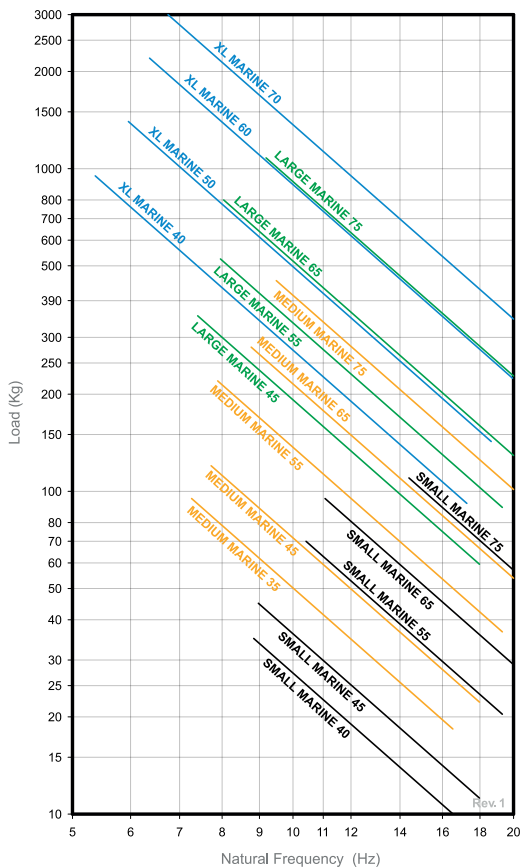

LOAD DEFLECTION GRAPHS
AMC MECANOCAUCHO® MARINE ENGINE MOUNT

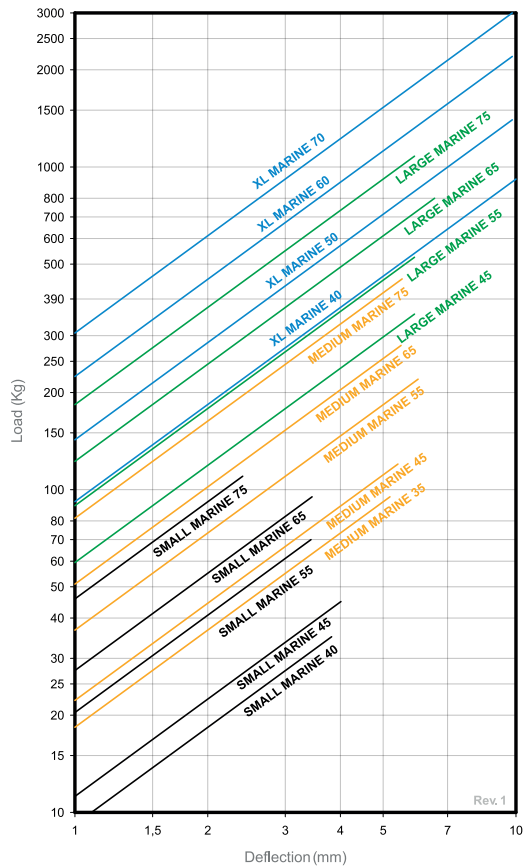

MARINE MOUNT TYPE XD

DESCRIPTION

The XD Marine type AMC-MECANOCAUCHO® mounts are ideal for mobile applications where a higher degree of isolation is required.

Its specific design allows lower vertical and radial stiffness rates. This feature is particularly useful on those applications where a high vibration isolation rate is required even if the machine runs at low idle speeds. The metal parts are robust and incorporate a fail-safe device in order to resist traction forces.

TECHNICAL CHARACTERISTICS

- The cast aluminum bell has been designed to withstand to great dynamic shocks while the rubber compound is guided in order to avoid relative displacements.
- The rubberized baseplate and the aluminum top cap provide a higher resistance to marine corrosive environments, improving the performance of traditional marine antivibration mounts.
- The mounts have a clear identification of rubber hardness on the baseplate.
- The rubber compound is protected against oil contamination, O3 and UV rays.
- The failsafe device avoids rubber working at traction and limits the vertical ascendant movement.
- The different stiffness rates per axis, allow low roll natural frequencies of the system. This feature provides a higher vibration isolation degree on engines. The fact of having a lower vertical stiffness perfectly suits 3 cylinder engines working at low idle speeds.
- The higher longitudinal stiffness allows the mount to withstand thrust forces. This feature provides stability and reduces longitudinal movements of the engine. For marine application installations, please contact the technical department of AMC-MECANOCAUCHO®.
- Maximum leveling: 3 mm. For further leveling, we recommend to use shims.

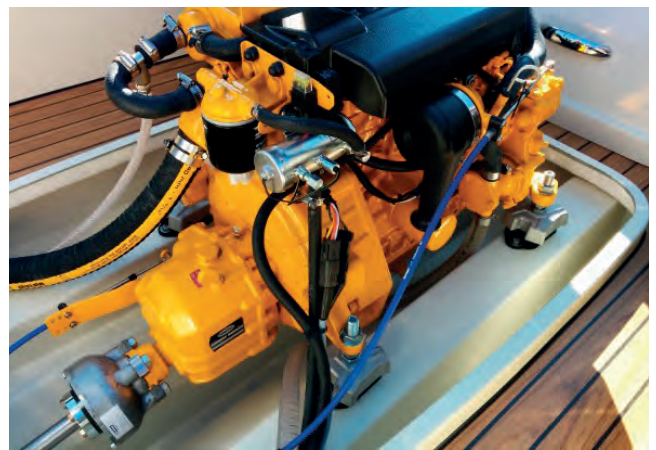
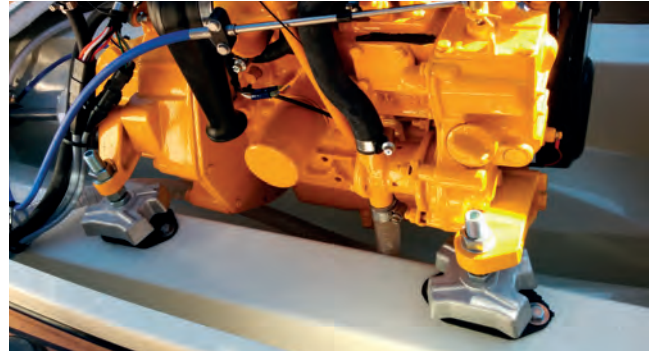

Example of installation on a 3cyl engine

SECTION A-A

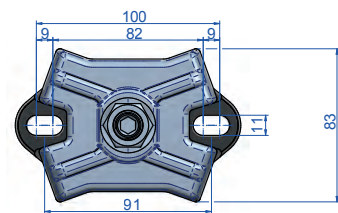
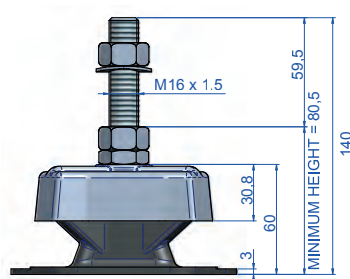
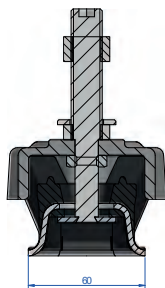

Type	Weight (gr)	Shore	Load kg max.	Code
MARINE MOUNT type XD	655	40 Sh	40	136151
		50 Sh	60	136152
		60 Sh	75	136153
		70 Sh	100	136154

MARINE MOUNT TYPE XT



DESCRIPTION

The AMC Mecanocaucho® MARINE XT Captive anti vibration mounts are anti vibration elements which work the rubber in both shear and compression. Their design has been tailored to provide a specific stiffness in each axis, a key benefit is providing a reduced roll natural frequency for engine installations.

The AMC Mecanocaucho® MARINE XT Captive mount is especially recommended for harsh applications where vibration isolation is a crucial factor, such as the isolation of rotating or mobile machines that are continuously subjected to shock forces. A high level of corrosion resistance is achieved which ensures protection from substances such as dripping oil/diesel and also in applications where there is exposure to the elements. Furthermore, thanks to their high stiffness in one of its directions, excellent results can be achieved for applications in which the thrust from the engine is high.



TECHNICAL CHARACTERISTICS

- AMC-MECANOCAUCHO® Marine XT anti vibration mounts have a special design that provides 3 different stiffness values in the 3 different directions, the highest being the one in the longitudinal direction. This design allows the mounts to face high longitudinal loads (thrust loads produced by marine engines) while their low lateral and vertical stiffness values allow them to keep a high isolation level against the main excitations from the crankshaft of the engine (which occurs at the plane with the lowest stiffness values of the mount).
- The top metal hood protects the rubber from the Ozone, UV rays, diesel or oils which could damage the rubber.
- The metal parts have a suitable anticorrosive treatment for outdoor applications. RoHs compliant.
- They have an interlocking metal component that provides a fail-safe protection for mobile applications. This device limits vertical movement when the mounting is submitted to shock inputs.
- The mounts are clearly identified, the baseplates are engraved with the type and hardness making it possible to easily recognize the part even after several years of use.
- Maximum leveling: 3 mm. For further leveling, we recommend to use shims.

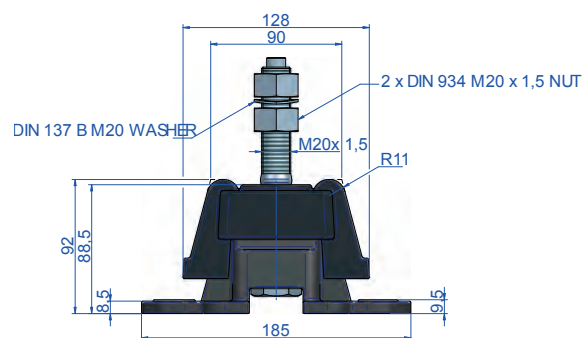
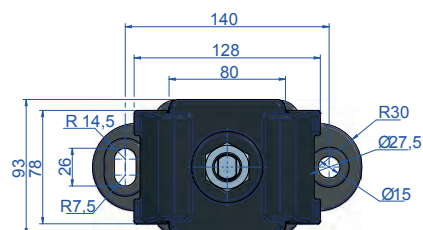

Type	Weight (gr)	Shore	Load kg max.	Code
MARINE MOUNT type XT	4659	35 Sh	150	136330
		45 Sh	225	136331
		55 Sh	350	136332
		65 Sh	500	136333

HYDRAULIC MOUNTS



DESCRIPTION

The AMC MECANOCAUCHO® Hydraulic mounts combine a spring and a hydraulic damper in a single compact unit that allows tuning of the spring and damper independently.

This provides flexibility in matching the dynamic characteristics of the isolator to the requirements of the application.

The internal architecture of the mount is composed of a new system that bonds the rubber to the metal parts in order to eliminate any leakage of the dampening fluid when the mount is submitted to high magnitude shocks.

For good isolation, low damping is required. For motion control, high dampening is required. The MECANOCAUCHO® hydraulic mounts accommodate these conflicting requirements. The fluid cavity is divided into two chambers with an orifice in between, so that motion of the elastomeric element causes fluid to flow from one chamber to the other, dissipating energy and thus creating damping in the system.

These mounts are particularly interesting for those installations that require a soft isolator for good isolation but still require motion control under transient (shock) inputs or when operating close to the isolation system's resonant frequency.

TECHNICAL CHARACTERISTICS

- The AMC MECANOCAUCHO® Hydraulic mounts have an interlocking metal component that provides a fail-safe protection for mobile applications. This device limits the ascending vertical movement when the mounting is submitted to shocks at traction.
- The thickness of the metal parts make this mount robust and suitable for off-road applications. The metal parts have a suitable anticorrosive treatment for outdoor applications. RoHS compliant.

APPLICATIONS

The AMC MECANOCAUCHO® Hydraulic mounts have been primarily designed as engine and operator cab isolator in vehicular off highway and agricultural applications.

It is particularly interesting for those engines that operate on a variable rotating speed that must pass the natural frequency of the system during its normal functioning. Examples of this may be engines of 1,2,3 or 4 cylinders used on construction or agricultural equipment.

It is also interesting for cabins where vibration isolation is required for operator comfort purposes but as well stability when the cabin is submitted to transient shocks.



Picture of an engine application.

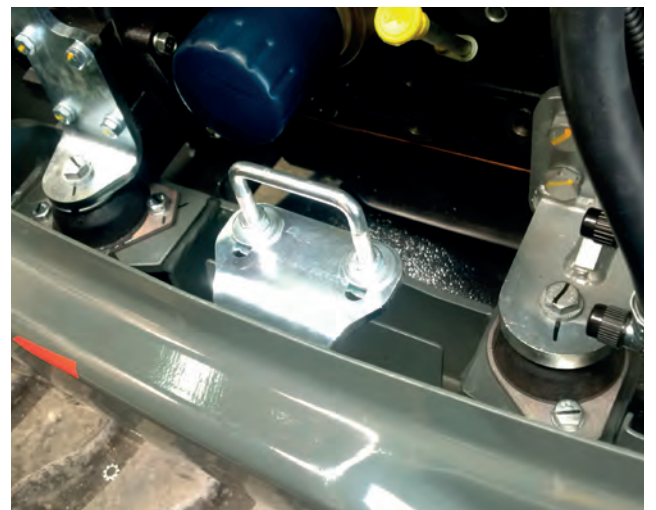

HYDRAULIC MINI	HYDRAULIC SMALL	HYDRAULIC SMALL RECT.	
HYDRAULIC MEDIUM	HYDRAULIC MEDIUM RECT.	HYDRAULIC MEDIUM HS2	
HYDRAULIC MEDIUM HS4	HYDRAULIC HSR	HYDRAULIC HSR RECT	
HYDRAULIC XR C	HYDRAULIC XR	HYDRAULIC LARGE	HYDRAULIC LARGE RECT.

Type	Tightening torque Max (Nm)	Weight (gr)	Max. Load (kg)	Shore	Code
MINI	41	335	20	40 Sh	177031
			30	50 Sh	177032
			50	60 Sh	177033
			70	70 Sh	177034
SMALL	41	917	60	40 Sh	177001
			100	50 Sh	177002
			145	60 Sh	177003
			180	70 Sh	177013
SMALL RECT.	41	938	60	40 Sh	177015
			100	50 Sh	177016
			145	60 Sh	177017
			180	70 Sh	177018
MEDIUM	71	1030	100	40 Sh	177004
			150	50 Sh	177005
			200	60 Sh	177006
			250	70 Sh	177011
MEDIUM RECT.	71	1050	100	40 Sh	177022
			150	50 Sh	177021
			200	60 Sh	177023
			250	70 Sh	177024
MEDIUM HS 2	71	1030	125	40 Sh	177045
			200	50 Sh	177046
			250	60 Sh	177047
			350	70 Sh	177048
MEDIUM HS 4	71	1050	125	40 Sh	177035
			200	50 Sh	177036
			250	60 Sh	177037
			350	70 Sh	177038
HSR	71	1305	125	40 Sh	177306
			180	50 Sh	177307
			250	60 Sh	177308
			300	70 Sh	177309
HSR RECT	71	1302	125	40 Sh	177388
			180	50 Sh	177389
			250	60 Sh	177390
			300	70 Sh	177391
XR C	175	1680	125	40 Sh	177396
			200	50 Sh	177397
			290	60 Sh	177398
			380	70 Sh	177399
XR	170	1440	125	40 Sh	177392
			200	50 Sh	177393
			290	60 Sh	177358
			380	70 Sh	177395
LARGE	350	2445	235	40 Sh	177007
			295	50 Sh	177008
			345	60 Sh	177009
			410	70 Sh	177014
LARGE RECT.	350	2713	235	40 Sh	177041
			295	50 Sh	177042
			345	60 Sh	177043
			410	70 Sh	177044

OPERATION AND ASSEMBLY

A hook wrench should be used in the slots to avoid the rotation movement of the rubber.

TECHNICAL ADVICE FOR FOPS ROPS APPROVAL

AMC-MECANOCAUCHO's technical department will be pleased to offer you advice on correct installation procedures to achieve FOPS/ROPS tests approvals.

These pictures show a typical traction test on rectangular hydraulic medium mount subjected to loads up to 4 Tonnes without destruction of the part. For more information on this topic, please contact our technical department.

TRACTION TEST (Hydraulic medium square)

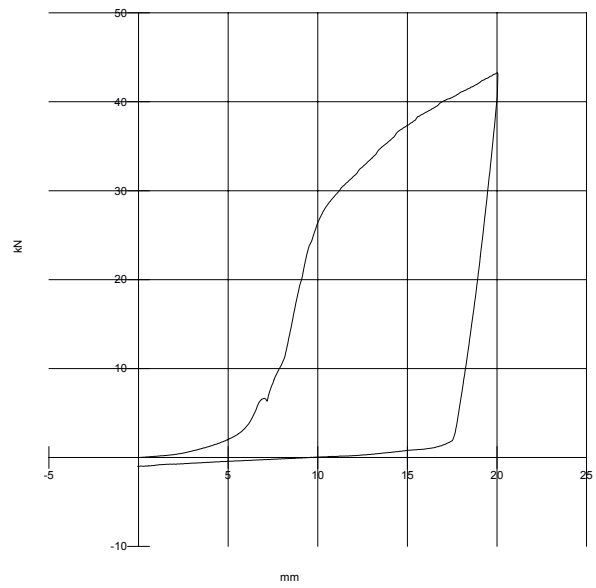

DAMPING COEFFICIENT

DYNAMIC STIFFNESS

LOAD DEFLECTION

MINI

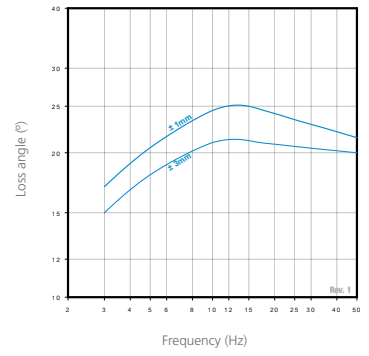
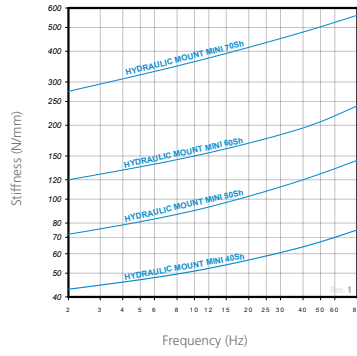
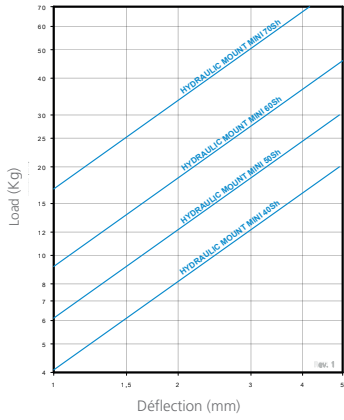

SMALL

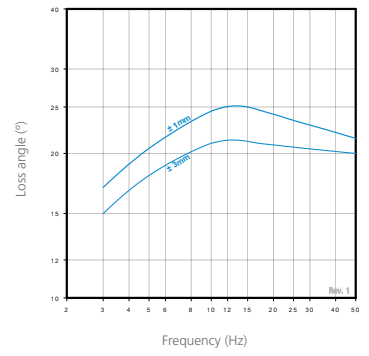
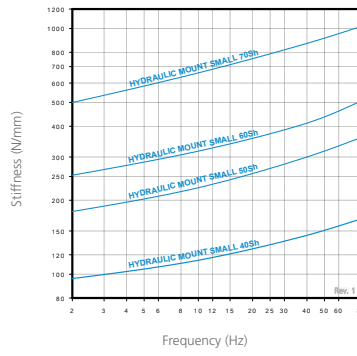
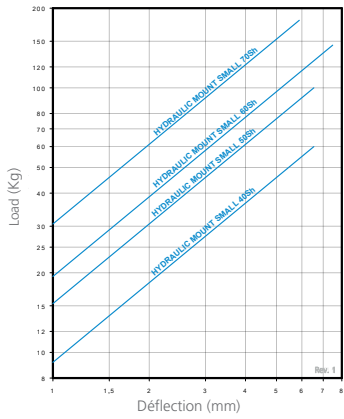

MEDIUM

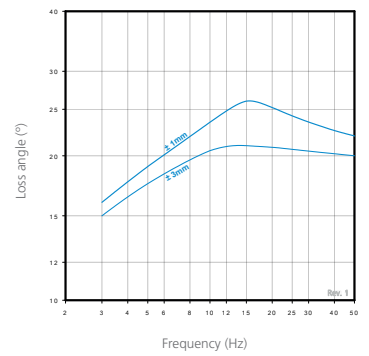
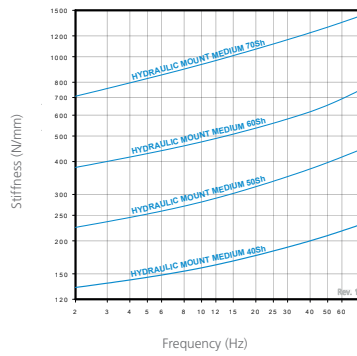
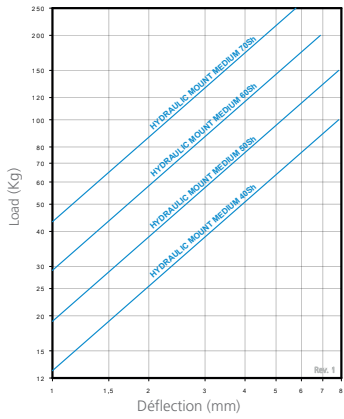

MEDIUM HS

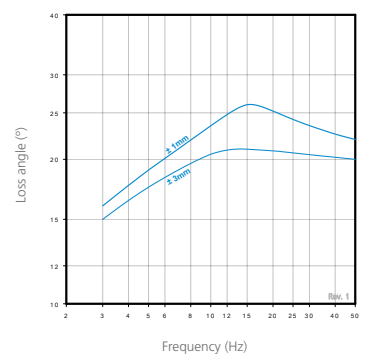
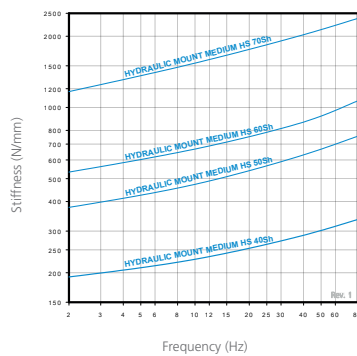
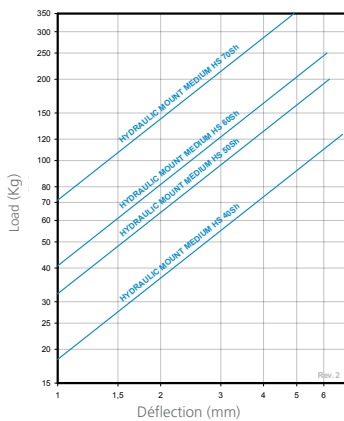

DAMPING COEFFICIENT

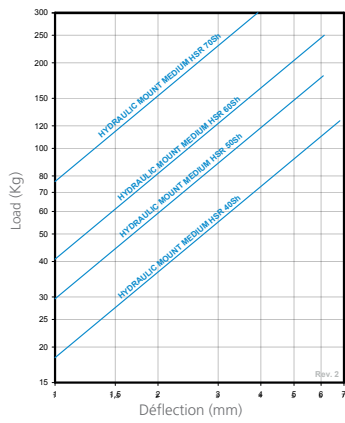

DYNAMIC STIFFNESS

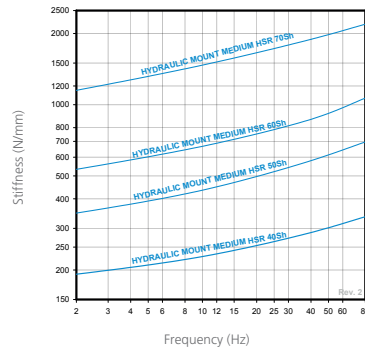

LOAD DEFLECTION

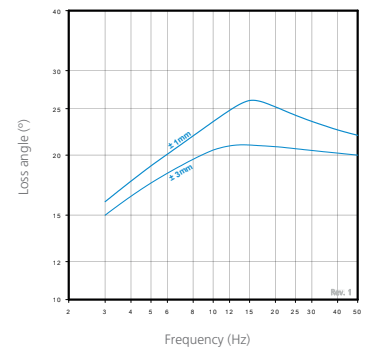

MEDIUM HSR

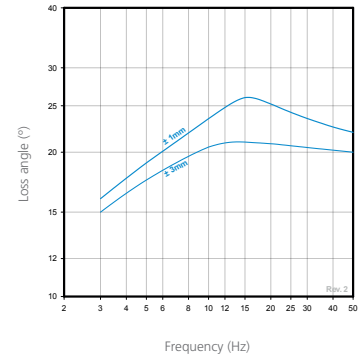
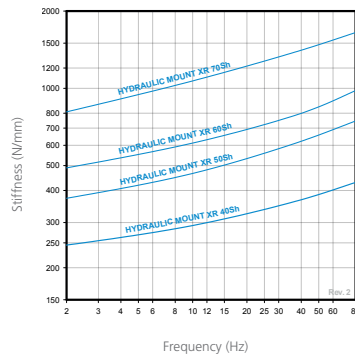
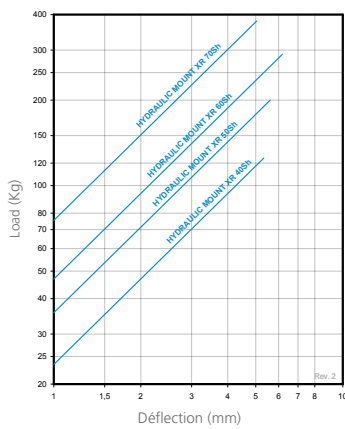

XR

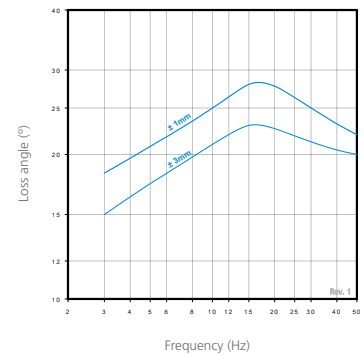
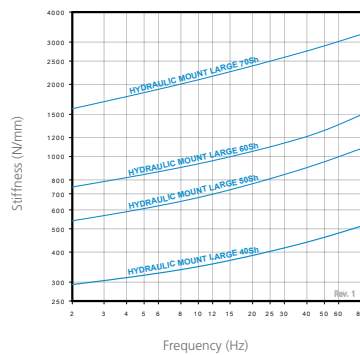
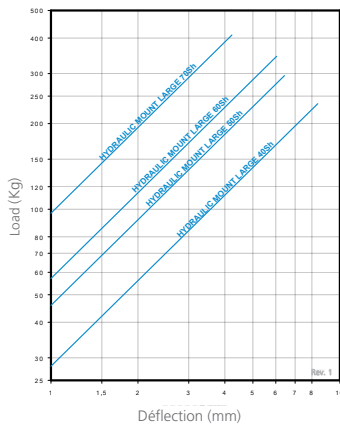

LARGE

HYDRAULIC CONES



DESCRIPTION

The AMC-MECANOCAUCHO® hydrocone is a combination of a spring component and a hydraulic shock absorber in the shape of a cone. With this both components can be tuned to each other.

For good vibration insulation you need a low dampening coefficient but for movement control you need a high dampening coefficient.

The AMC MECANOCAUCHO® hydrocone combines these two completely different requirements in one single bearing.

This gives you the opportunity to adapt the dynamic properties of the insulator to the individual requirements of the application.

Our vibration dampeners do this by the hydraulic fluid flowing from one chamber to the next as a result of the movement of the rubber component. An energetic dissipation results from this process.

TECHNICAL CHARACTERISTICS

- AMC MECANOCAUCHO® hydraulic shock absorbers have an advanced breakaway device inside the bearing that prevents tensile forces on the elastomer by limiting its upward vibration stroke. The newly-developed internal structure of the vibration dampener consists of a metal part system. The elastomer is vulcanised to the whole of this. This prevents a loss of hydraulic fluid should the vibration dampener be subject to great dynamic overloads.
- The thickness of the metal parts ensures that the dampener is strong enough for mobile applications. The metal parts are treated with a resistant corrosion protection for outdoor use.

APPLICATIONS

The AMC MECANOCAUCHO® hydrocone is predominantly designed to insulate the vibration in engines and cabs in off-road vehicles (construction, agricultural and local authority vehicles).

The hydrocone has the necessary resilience to achieve a high level of decoupling. However, it also has the necessary stability for these applications in the event of impacts which thus prevents the vehicles from rocking. This ensures a high level of comfort as well as an immediate working and driving experience.

Another advantage becomes apparent with variable speed applications which are within the resonance frequency range in normal operation. This resonance is significantly reduced with the hydrocone.



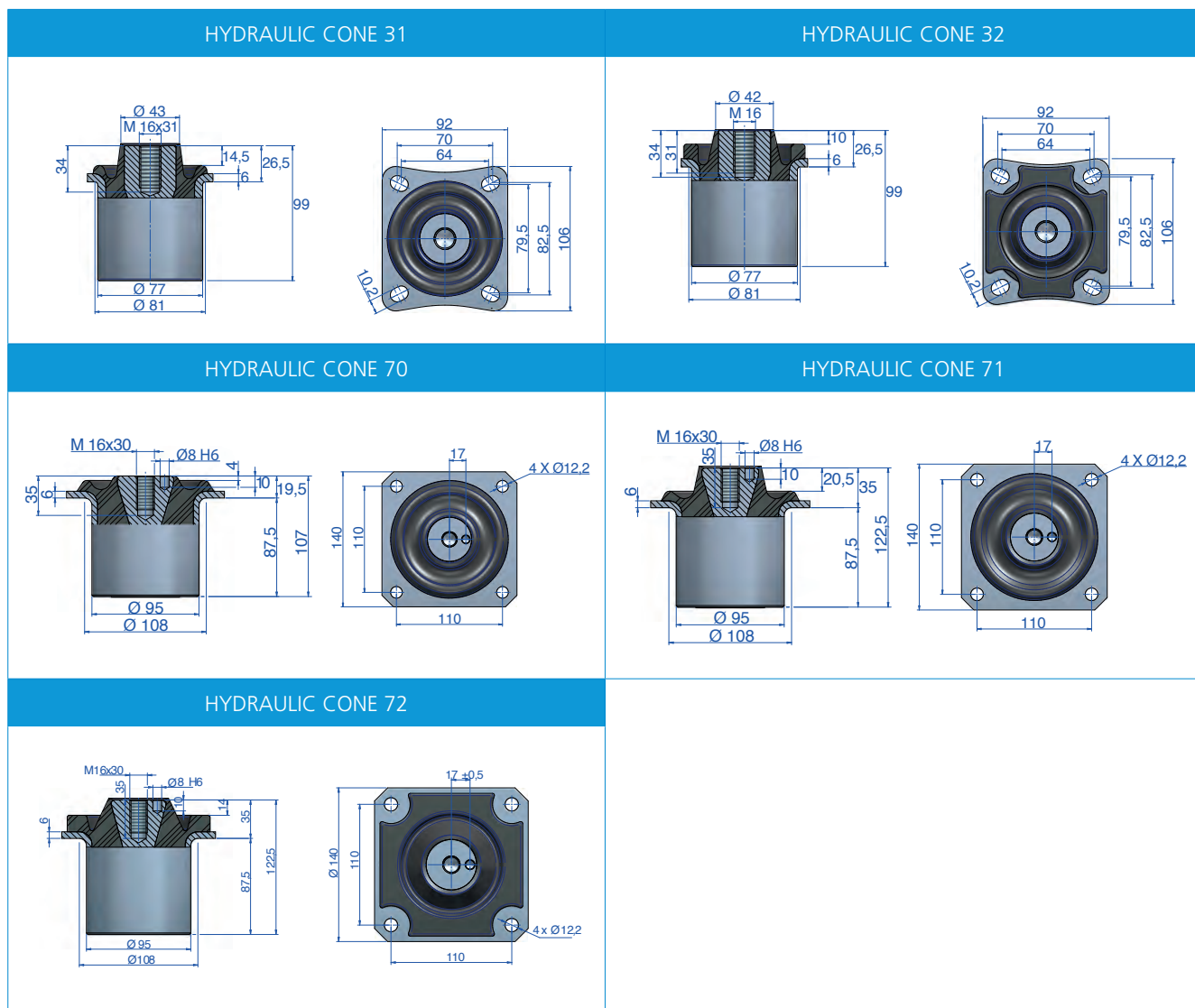

Type	A (mm)	B (mm)	C (mm)	D (mm)	E (mm)	F (mm)	H (mm)	I (mm)	J (mm)	K (mm)	L (mm)	N (mm)	O (mm)	Code	Load (kg)	Shore
HYDRAULIC CONE MOUNTS 31	M16	79,5	70	82,5	64	81	72,5	77	10,2	25	6	-	-	177081	250	40 Sh
														177085	310	45 Sh
														177082	370	50 Sh
														177083	500	60 Sh
														177084	550	70 Sh
HYDRAULIC CONE MOUNTS 32	M16	79,5	70	82,5	64	81	72,5	77	10,2	26,5	6	10		177104	250	40 Sh
														177105	370	50 Sh
														177106	500	60 Sh
														177107	550	70 Sh
														177051	300	40 Sh
HYDRAULIC CONE MOUNTS 70	M16	110	140	140	110	108	104,5	95	12,2	19,5	6	4	-	177052	500	50 Sh
														177053	700	60 Sh
														177054	900	70 Sh
														177055	400	40 Sh
														177056	600	50 Sh
HYDRAULIC CONE MOUNTS 71	M16	110	140	140	110	108	120	95	12,2	35	6	19	8	177057	900	60 Sh
														177058	1000	70 Sh
														177294	400	40 Sh
														177295	600	50 Sh
														177296	900	60 Sh
HYDRAULIC CONE MOUNTS 72	M16	110	140	140	110	108	120	95	12,2	35	6	14	8	177297	1000	70 Sh

Washers should be used, if the rubber surface is not covered with the contact surface.
Washers upon request.

Type	\varnothing_{ext} (mm)	\varnothing_{int} (mm)	Thickness (mm)	Code
HYDRAULIC CONE MOUNTS 31	80	16,5	5	606488
HYDRAULIC CONE MOUNTS 32	96	16,5	5	610147
HYDRAULIC CONE MOUNTS 70	110	16,5	5	610296
HYDRAULIC CONE MOUNTS 71	110	16,5	5	610296
HYDRAULIC CONE MOUNTS 72	130	16,5	5	610305

HYDRAULIC CONES 31

HYDRAULIC CONES 32

HYDRAULIC CONES 70

LOAD DEFLECTION

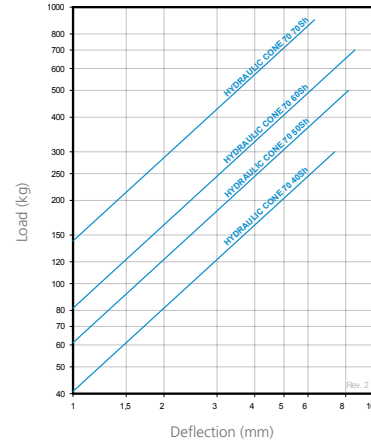
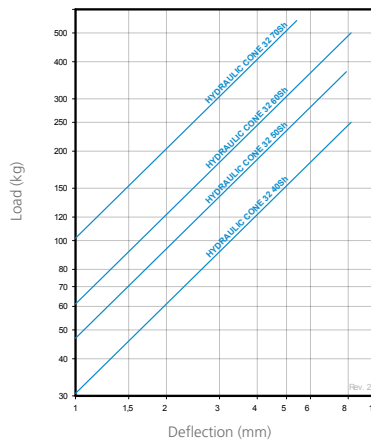
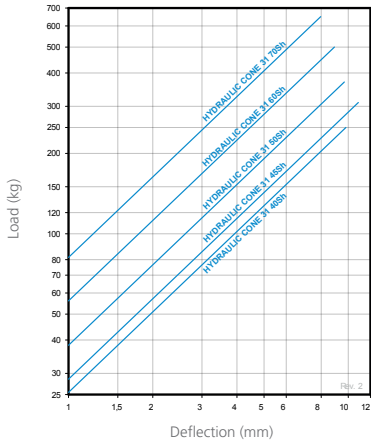

DYNAMIC STIFFNESS

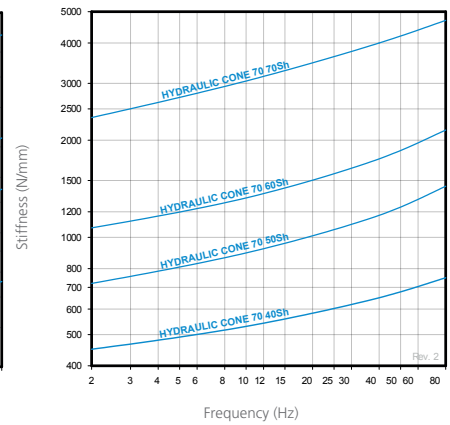
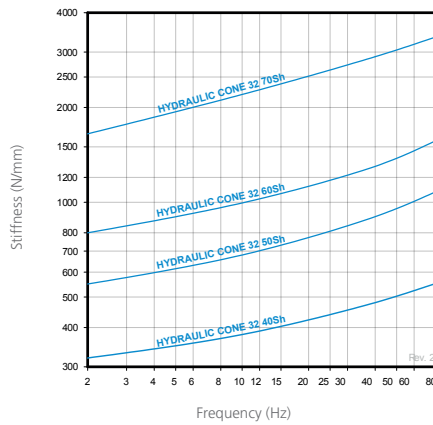
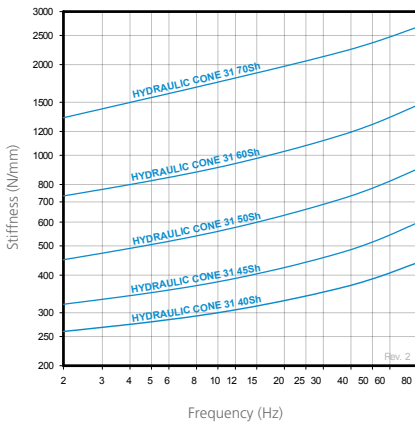

DAMPING COEFFICIENT

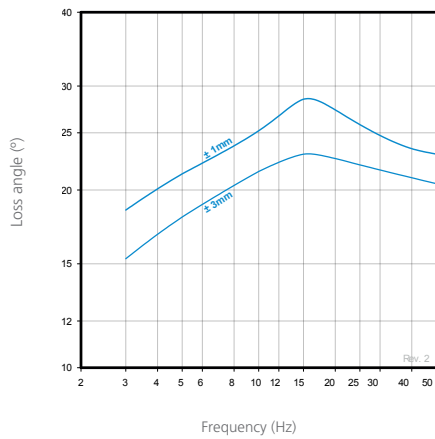
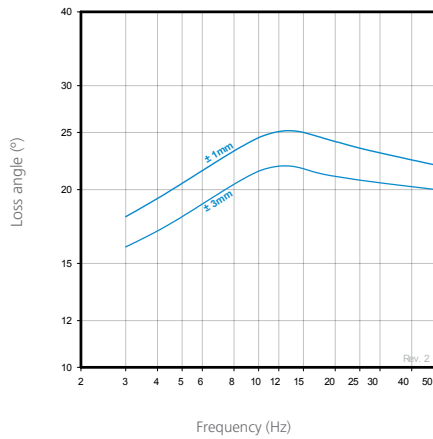
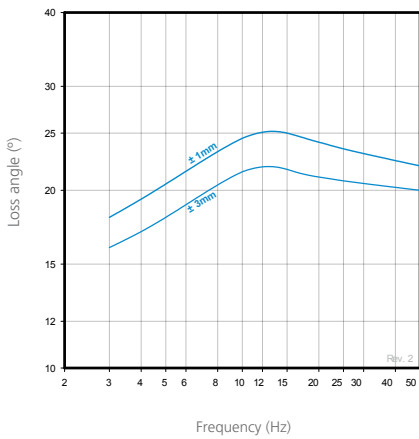

HYDRAULIC CONES 71

HYDRAULIC CONES 72

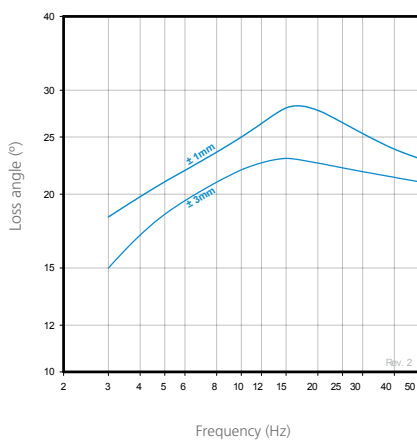
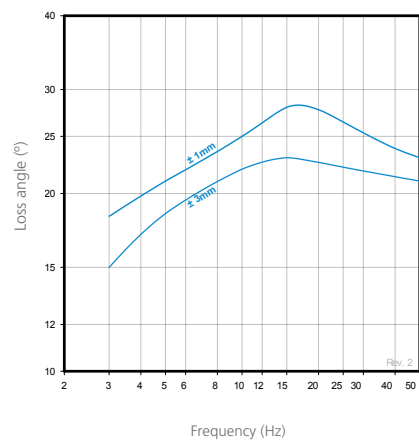
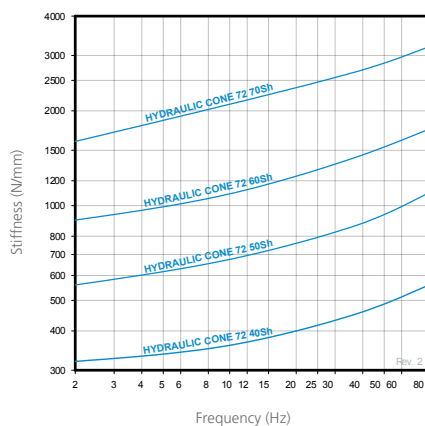
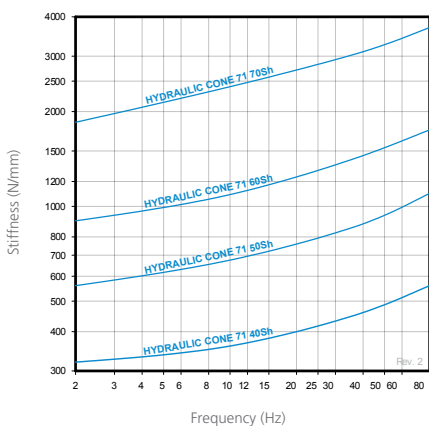
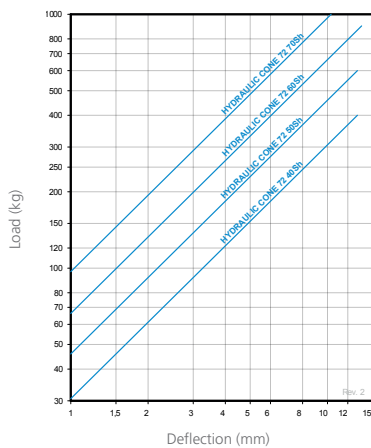
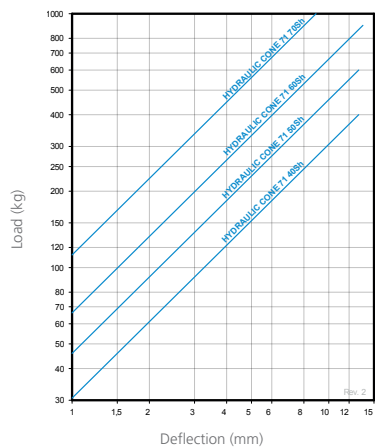



CONES

DESCRIPTION

The AMC MECANOCAUCHO® cones work the rubber in shear compression. They are composed of two parallel conical metal parts. They have two washers, one as a buffer and the other for centering.

TECHNICAL CHARACTERISTICS

- The AMC MECANOCAUCHO® Cone mounts are safe and stable elements. They do not allow the suspended elements to tilt, while being flexible enough to avoid the transmission of noise and vibration through the structure.
- They are supplied with stop and centering washers. This renders deflection above the limits of the Mecanocaucho® Cones impossible, even at extreme loads.
- The washers protect the natural rubber (which is highly elastic and highly resistant) from ozone and aging, as well as from metal knocks and dripping oil. The characteristic deflection curves of the AMC MECANOCAUCHO® Cone mounts with centering washer are quite linear, increasing progressively as the load increases. Thanks to this they can safely dampen overloads of up to three times the maximum admissible load.

APPLICATIONS

The AMC MECANOCAUCHO® cones have been designed to use them in engines and auxiliary machinery for static applications and for applications in all type of vehicles. Also used for cabs. You can contact our technical department.

CONICAL MOUNTS WITH CUTOUTS

The cutouts on the rubber section offer different horizontal/vertical stiffness ratios. This feature is specially interesting for those applications where a lower stiffness is required in one of the axes.

Our technical department can provide you the elastical constants and can recommend you the optimal position of the cutouts.



CONE WITH CUTOUTS

Type	Weight (gr.)	Code	Load (kg)	Shore
00	126	137007	25	45 Sh
		137008	50	60 Sh
		137009	75	70 Sh
10	406	137001	75	45 Sh
		137002	140	60 Sh
		137003	210	70 Sh
12	407	137914	80	45 Sh
		137916	120	55 Sh
		137918	200	70 Sh
20	554	137031	120	45 Sh
		137034	200	60 Sh
		137039	330	70 Sh
30	1167	137041	140	40 Sh
		137043	190	50 Sh
		137042	300	60 Sh
		137044	370	70 Sh
35	1328	137065	200	45 Sh
		137067	450	60 Sh
		137068	760	70 Sh
38	1438	137961	300	40 Sh
		137962	400	50 Sh
		137963	650	60 Sh
120 NP	6890	137871	440	45 Sh
		137872	720	55 Sh

SOLID CONE



CONE WITH CUTOUTS



CONE TYPE 00

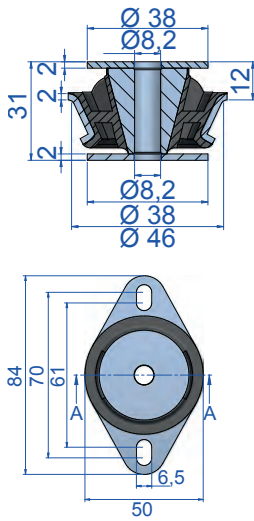

Top Washer Cone 00 code 610053
Lower Washer Cone 00 code 610053

CONE TYPE 10

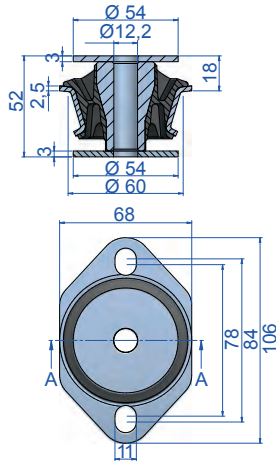

Top Washer Cone 10 code 611068
Lower Washer Cone 10 code 611068

CONE TYPE 12

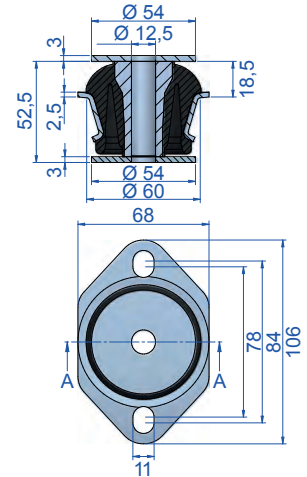

Top Washer Cone 12 code 611068
Lower Washer Cone 12 code 611068

CONE TYPE 20

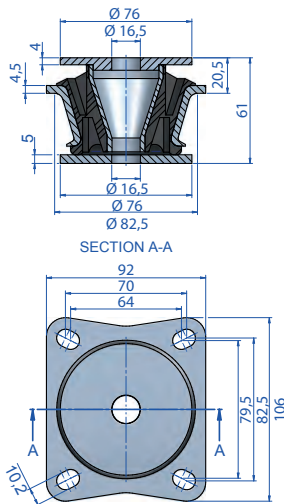

Top Washer Cone 20 code 610049
Lower Washer Cone 20 code 610050

CONE TYPE 30

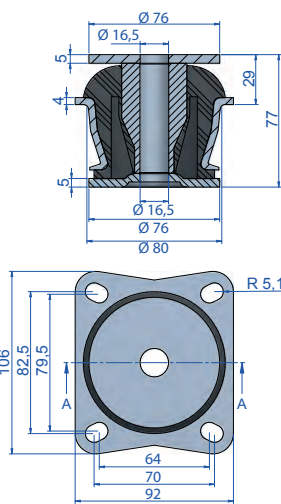

Top Washer Cone 30 code 608074
Lower Washer Cone 30 code 608125

CONE TYPE 35

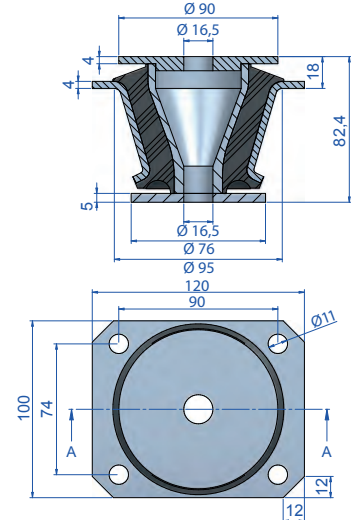

Top Washer Cone 35 code 608082
Lower Washer Cone 35 code 608097

CONE TYPE 38

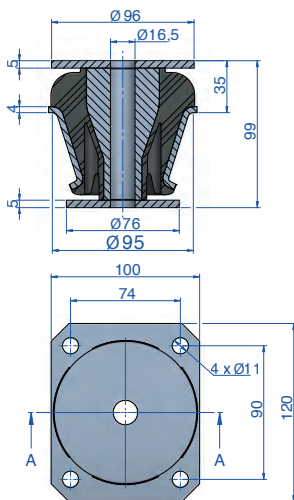

Top Washer Cone 38 code 610147
Lower Washer Cone 38 code 608074

CONE TYPE 120 NP

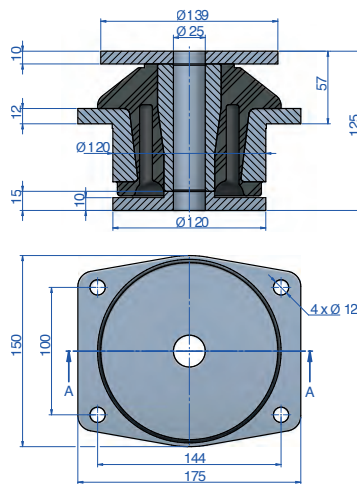

Top Washer Cone 120 code 606378
Lower Washer Cone 120 code 606379

NATURAL FREQUENCY
AMC MECANOCAUCHO® CONE WITH CUTOUTS

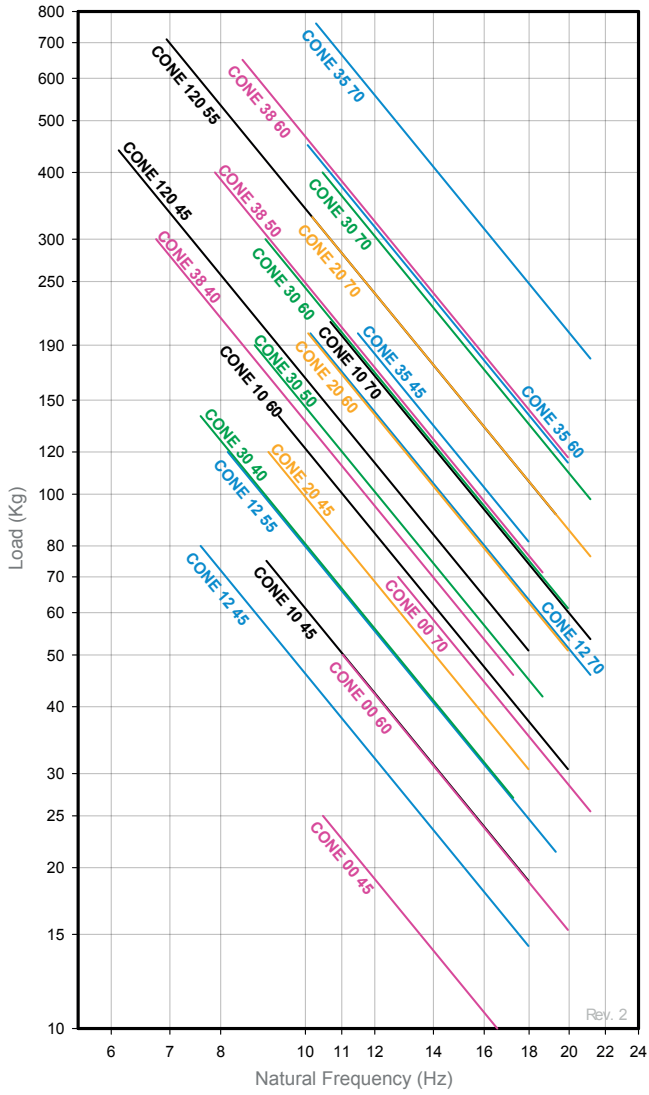

LOAD DEFLECTION GRAPH
AMC MECANOCAUCHO® CONE WITH CUTOUTS

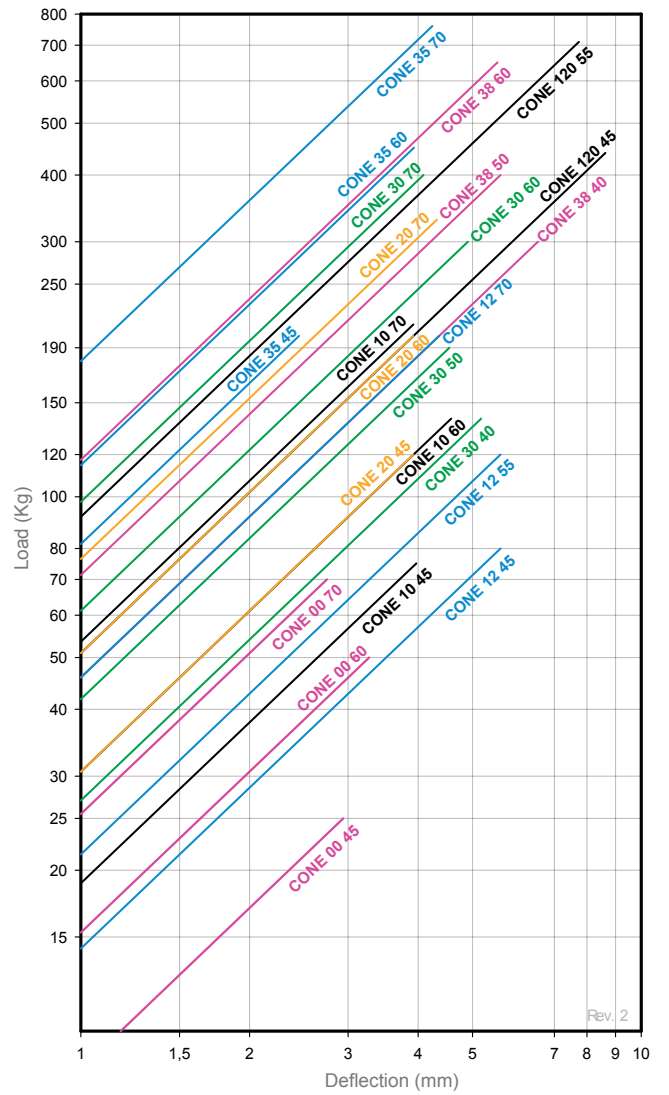



SOLID CONE

Type	Tightening torque Max (Nm)	Weight (gr)	Code	Max. Load (kg)	Shore
01	20,5	128	137005	40	45 Sh
			137006	70	60 Sh
			137015	105	70 Sh
02	71	132	137010	50	45 Sh
			137011	90	60 Sh
11	71	409	137021	100	45 Sh
			137022	180	60 Sh
			137023	270	70 Sh
13	71	450	137921	120	45 Sh
			137922	170	55 Sh
			137925	270	70 Sh
14 - 2 holes	71	643	137930	250	45 Sh
			137628	500	65 Sh
14 - 4 holes	71	662	137935	250	45 Sh
			137936	450	662
			137937	690	70 Sh
17	71	410	137903	160	45 Sh
			137904	250	60 Sh
			137905	350	70 Sh
21 - 2 holes	113	787	137470	180	45 Sh
			137472	300	60 Sh
			137474	500	70 Sh
21 - 4 holes	113	560	137071	180	45 Sh
			137074	300	60 Sh
			137079	500	70 Sh
27	170	1175	137142	245	40 Sh
			137143	350	50 Sh
			137144	500	60 Sh
31	170	1188	137063	310	50 Sh
			137061	500	60 Sh
			137062	750	70 Sh
33	170	1462	137075	300	45 Sh
			137077	600	60 Sh
			137078	900	70 Sh
36	170	1410	137171	400	45 Sh
			137172	700	60 Sh
			137173	1100	70 Sh
39	170	1438	137981	400	40 Sh
			137982	600	50 Sh
			137983	900	60 Sh
			137984	1100	70 Sh
40	245	1216	137081	420	45 Sh
			137082	690	60 Sh
			137083	1080	70 Sh
45	245	1751	137595	420	45 Sh
			137596	700	60 Sh
			137597	1100	70 Sh
60	350	1821	137091	900	45 Sh
			137092	1250	60 Sh
			137093	1560	70 Sh
62	170	1946	137208	450	45 Sh
			137226	1000	60 Sh
			137232	1400	70 Sh
65	350	2965	137176	500	50 Sh
			137177	1100	65 Sh
			137178	1560	75 Sh
70	600	3450	137101	1000	45 Sh
			137102	2100	60 Sh
			137103	2500	70 Sh
75	600	4230	137786	850	45 Sh
			137787	1600	60 Sh
121 NG	600	7840	137830	1750	55 Sh
			137833	2000	65 Sh
121 NP	600	6940	137841	730	45 Sh
			137829	1200	55 Sh
141	245	1039	137891	175	50 Sh
			137893	250	60 Sh

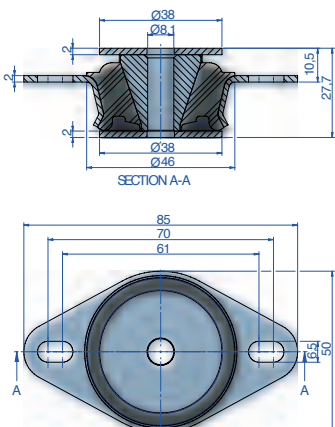
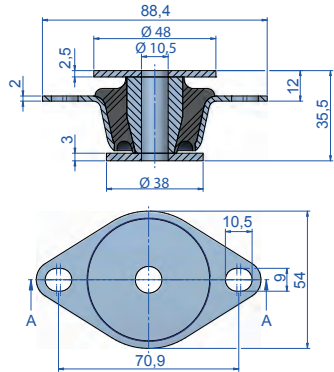
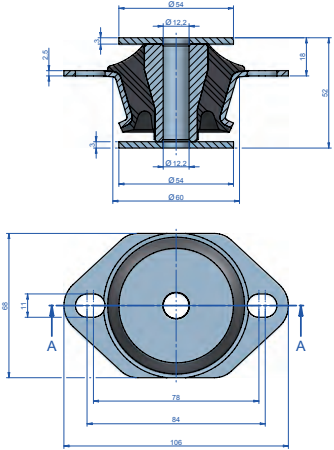
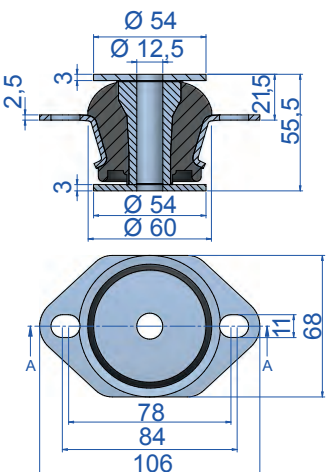
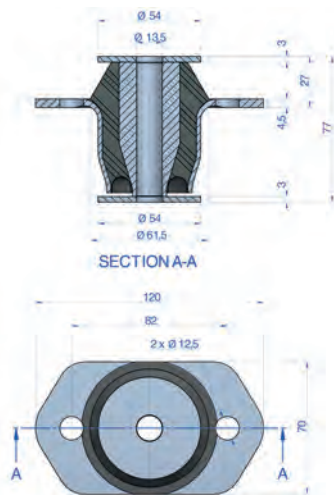
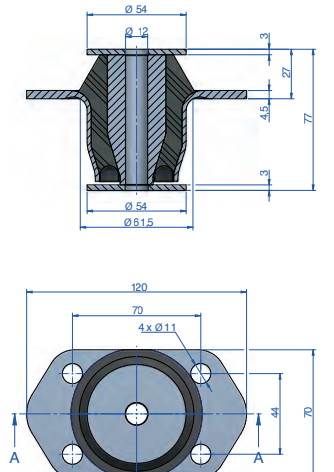
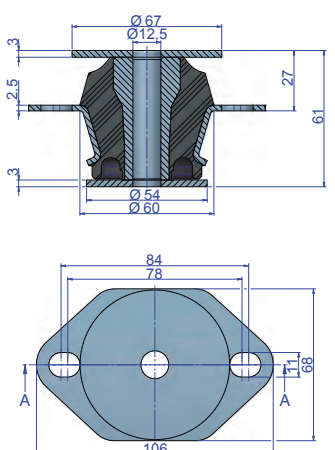
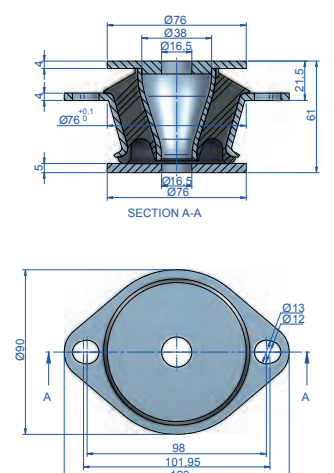
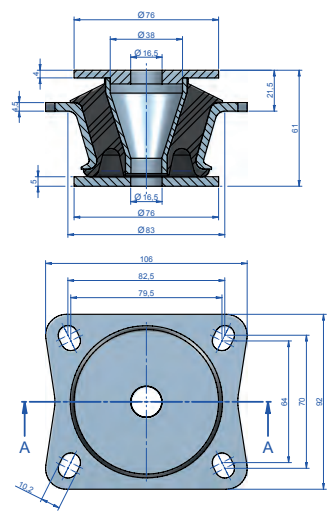

CONE TYPE 01	CONE TYPE 02	CONE TYPE 11
 <p>Included upper washer code 610053 Included lower washer code 610053</p>	 <p>Included upper washer code 610064 Included lower washer code 610064</p>	 <p>Included upper washer code 611080 Included lower washer code 611080</p>
CONE TYPE 13	CONE TYPE 14-2 HOLE	CONE TYPE 14-4 HOLE
 <p>Included upper washer code 611080 Included lower washer code 611080</p>	 <p>Included upper washer code 611080 Included lower washer code 611080</p>	 <p>Included upper washer code 611080 Included lower washer code 611080</p>
CONE TYPE 17	CONE TYPE 21-2 HOLE	CONE TYPE 21- 4 HOLE
 <p>Included upper washer code 606285 Included lower washer code 608074</p>	 <p>Included upper washer code 606285 Included lower washer code 608074</p>	 <p>Included upper washer code 606285 Included lower washer code 608074</p>

CONE TYPE 27

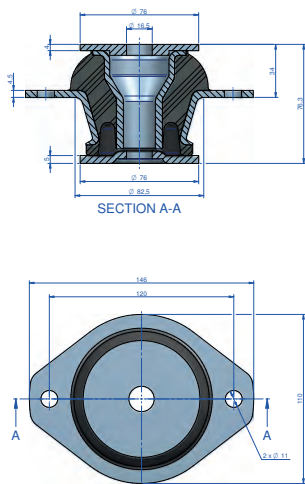

Included upper washer code 606285
Included lower washer code 608125

CONE TYPE 31

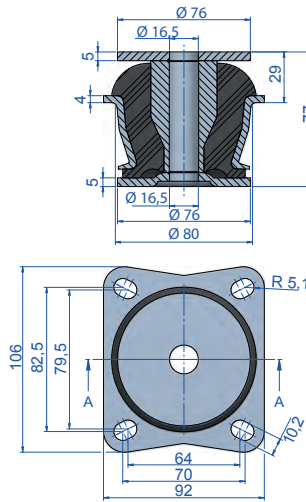

Included upper washer code 608074
Included lower washer code 608125

CONE TYPE 33

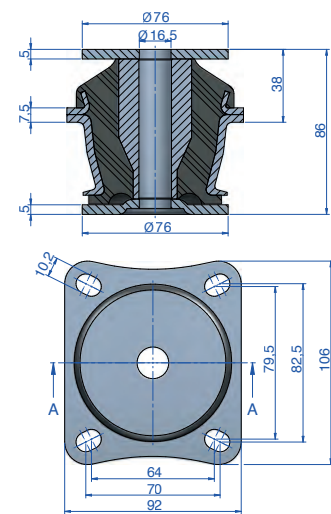

Included upper washer code 608074
Included lower washer code 608125

CONE TYPE 36

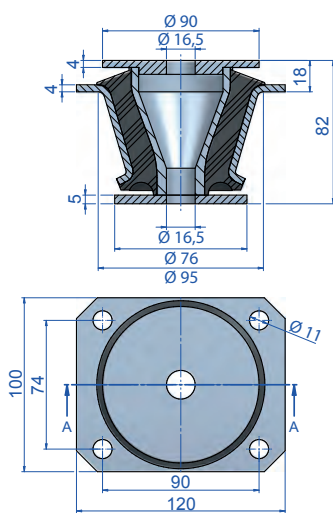

Included upper washer code 608082
Included lower washer code 608074

CONE TYPE 39

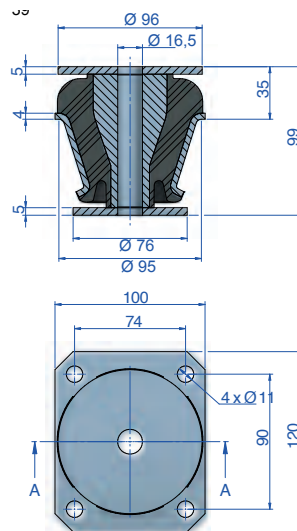

Included upper washer code 610147
Included lower washer code 608074

CONE TYPE 40

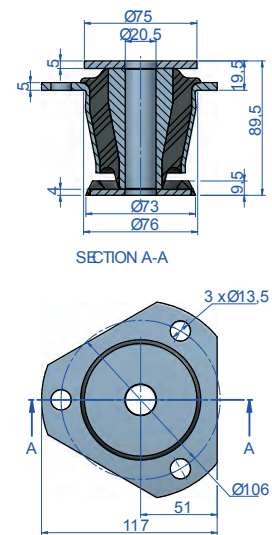

Included upper washer code 610027
Included lower washer code 608267

CONE TYPE 45

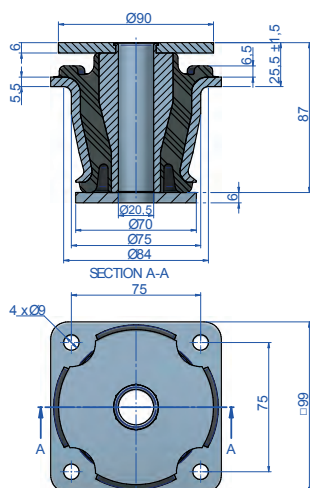

Included upper washer swagged from origin
Included lower washer code 606545

CONE TYPE 60

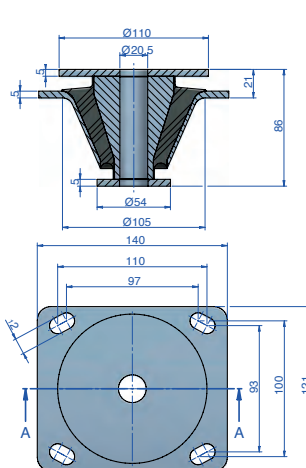

Included upper washer code 610032
Included lower washer code 610033

CONE TYPE 62

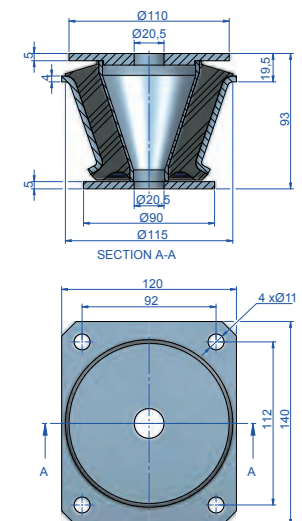

Included upper washer code 606571
Included lower washer code 606486

CONE TYPE 65

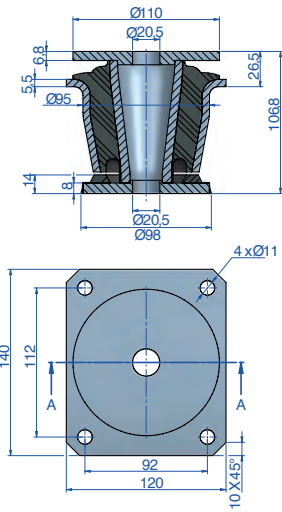

Included upper washer code 608144
Included lower washer code 608072

CONE TYPE 70

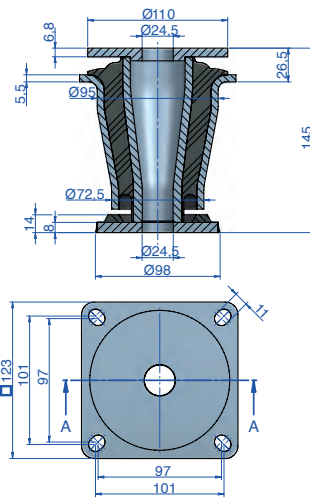

Included upper washer code 608033
Included lower washer code 608149

CONE TYPE 75

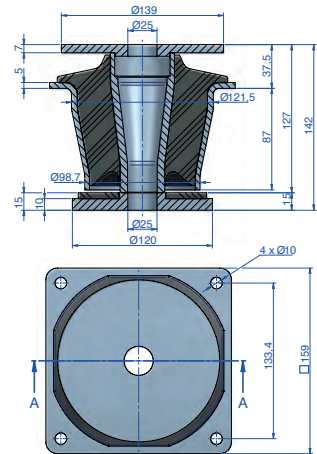

Included upper washer code 608332
Included lower washer code 606619

NG CONE TYPE 121

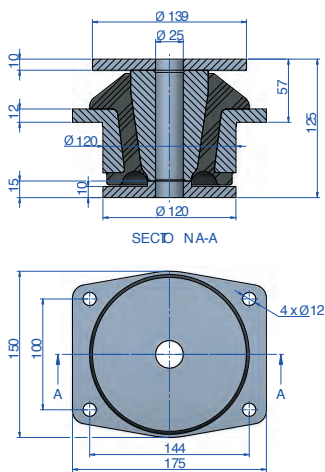

Included upper washer code 606378
Included lower washer code 606379

NP CONE TYPE 121

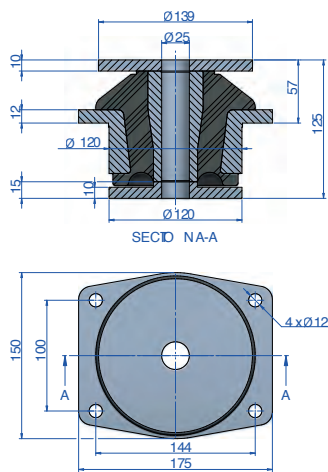

Included upper washer code 606378
Included lower washer code 606379

CONE TYPE 141

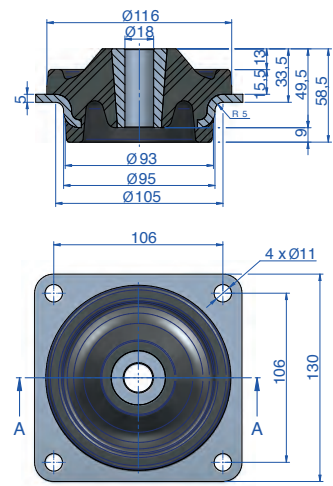

Included upper washer code 608074
Included lower washer code 608125

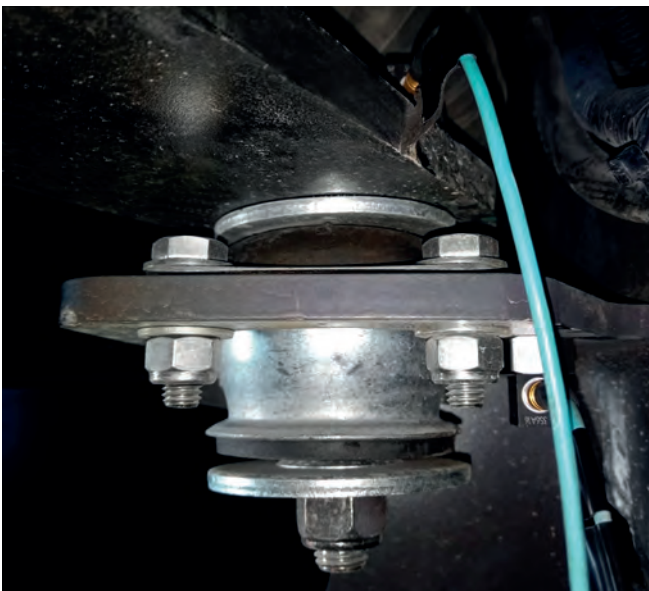

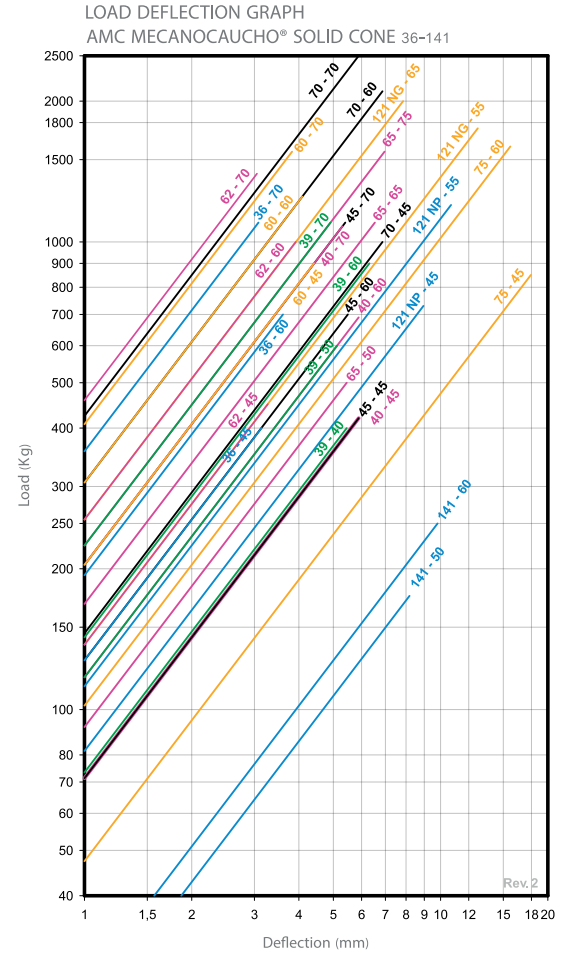
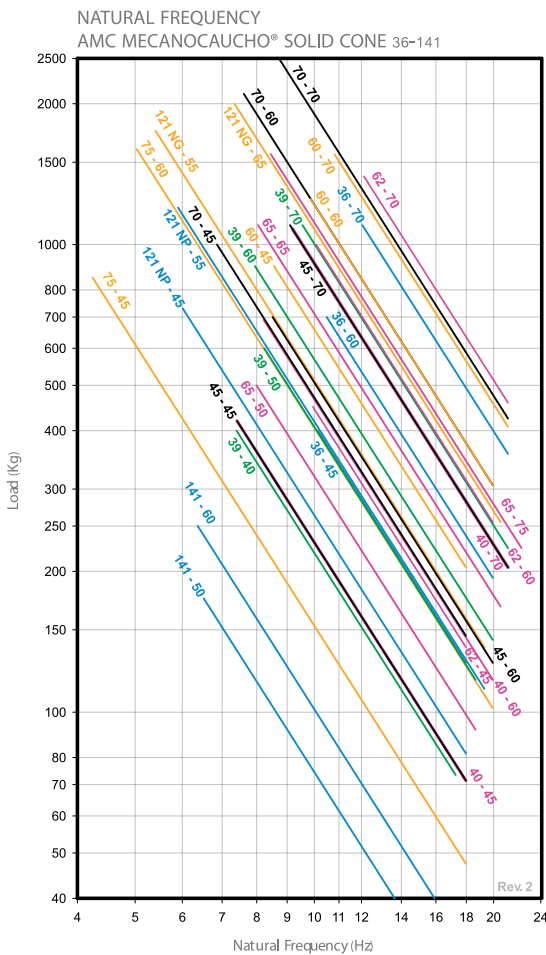
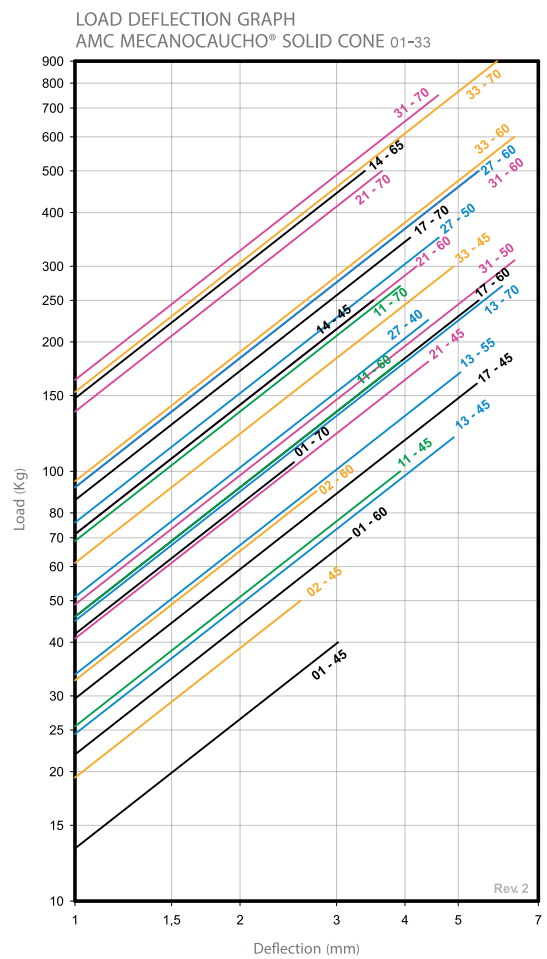
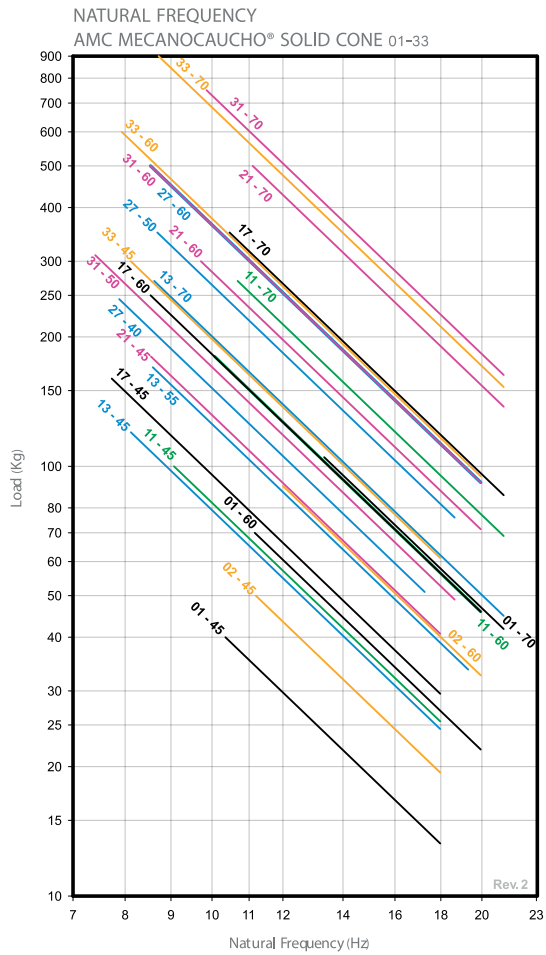

DSM (Dual Stiffness Mounts)



DESCRIPTION

The DSM Mounts provides an important pre-compression of the rubber section during assembly, this offers several advantages during operation. This design ensures effective vibration isolation during static conditions and excellent stability during dynamic shock conditions.



22

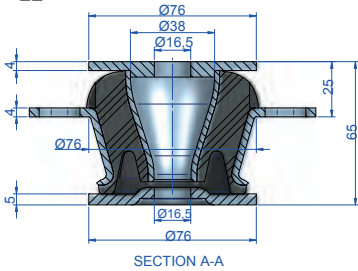

SECTION A-A

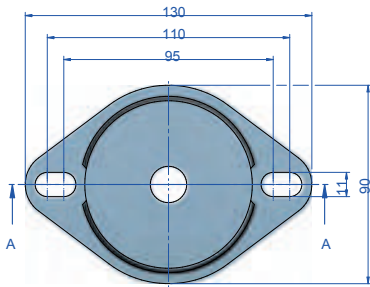

83

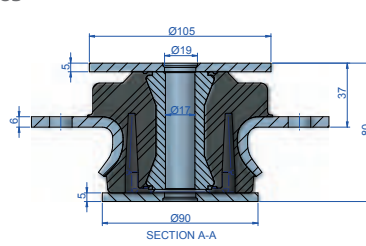

SECTION A-A

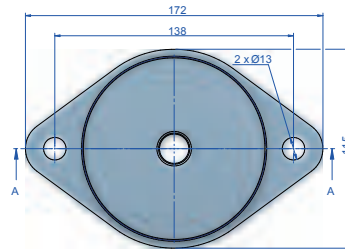

141

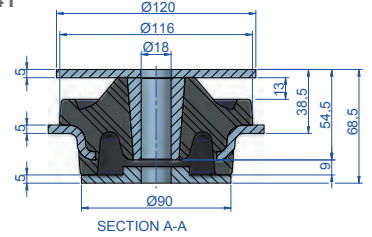

SECTION A-A

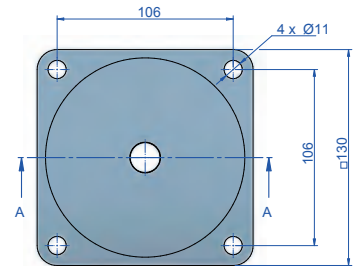

MAX. TIGHTENING TORQUE: 113 Nm

Type	Tightening torque Max (Nm)	Weight (gr)	Code	Max. Load (kg)	Shore
DSM 22	113	850	137460	250	50 Sh
			137461	150	45 Sh
DSM 83	71	2000	137462	250	55 Sh
			137463	350	65 Sh
DSM 141	245	1039	137464	175	50 Sh
			137465	250	60 Sh

NATURAL FREQUENCY GRAPHS

AMC MECANOCAUCHO® DSM 22

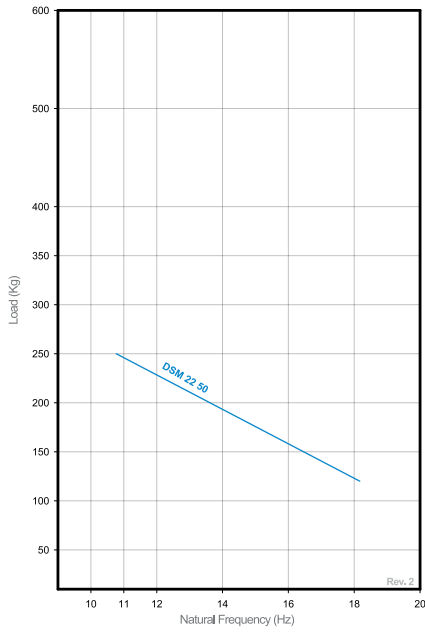

AMC MECANOCAUCHO® DSM 83

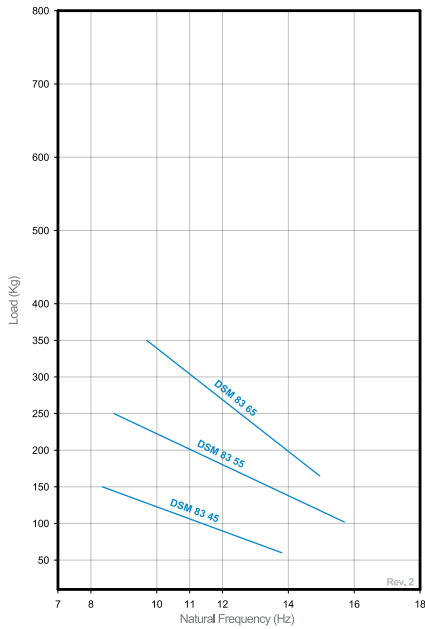

AMC MECANOCAUCHO® DSM 141

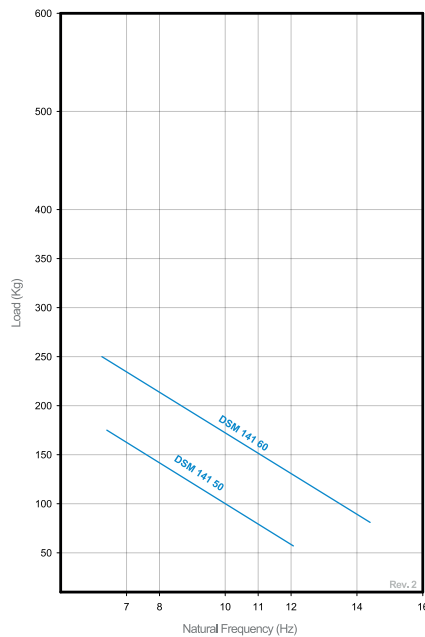

LOAD DEFLECTION GRAPHS

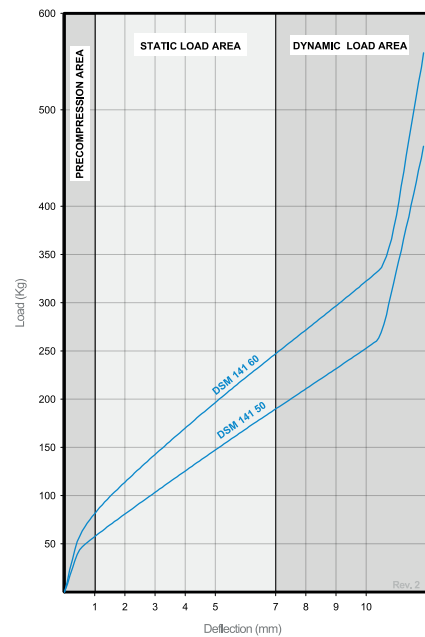
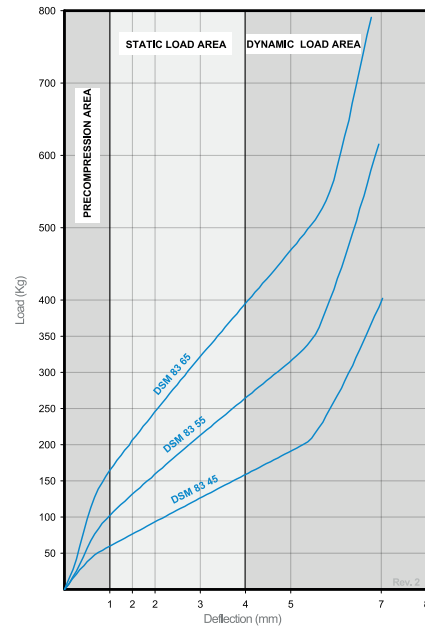
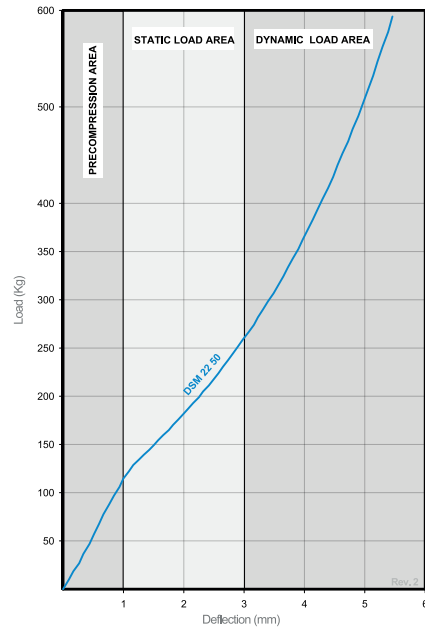

CONES WITH FIXATION FLANGE



DESCRIPTION

The cones with fixation flange from AMC MECANOCAUCHO® work the elastomer at shear compression. They are comprised of a high strength external metal armour and a conical internal that is placed concentrically.

TECHNICAL CHARACTERISTICS

The cones with fixation flange from AMC MECANOCAUCHO® are conceived to offer predominant axial elasticity under heavy loads. The used elastomer is a low dynamic rigidification elastomer, which makes it possible to obtain low natural frequencies thus maintaining excellent stability of the suspended unit.

The mount's radial stiffness is superior to the axial. This is particularly interesting for applications where great horizontal stability needs to be maintained.

The AMC MECANOCAUCHO® Cone 100 mount is supplied with a height adjuster. This makes it possible to easily align transmission shafts without having to use additional accessories to do so.

All the models also incorporate an interlocking metal part that allow them to act as a FAILSAFE system. Thanks to this, and to the ruggedness of the metal parts, this mount is suitable for applications where the suspended unit is submitted to great shocks.

APPLICATIONS

The AMC MECANOCAUCHO® cones with fixation flange have been designed specially for use in engines and auxiliary machinery for static applications and for applications in all kinds of vehicles.

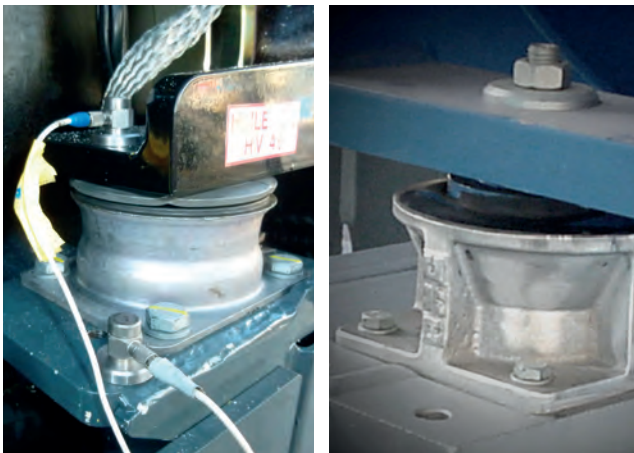

Type	Weight (gr.)	Code	Load (kg)	Shore
Cone 50 M16x2	1600	137085	120	40 Sh
		137086	170	50 Sh
		137087	250	60 Sh
		137088	300	70 Sh
		137231	120	40 Sh
Cone 50 M16x1,5	1600	137233	170	50 Sh
		137235	250	60 Sh
		137237	300	70 Sh
		137095	150	40 Sh
Cone 51 M16x2	1750	137096	220	50 Sh
		137097	320	60 Sh
		137098	420	70 Sh
		137241	150	40 Sh
Cone 51 M16x1,5	1750	137243	220	50 Sh
		137245	320	60 Sh
		137247	420	70 Sh
		Cone 100 A	9626	137213
Cone 100 B	9626	137214	2300	-
Cone 100 C	9626	137215	1600	-
Cone 200 A	29000	137810	8500	-
Cone 200 B	29000	137801	6500	-
Cone 200 C	29000	137805	3900	-

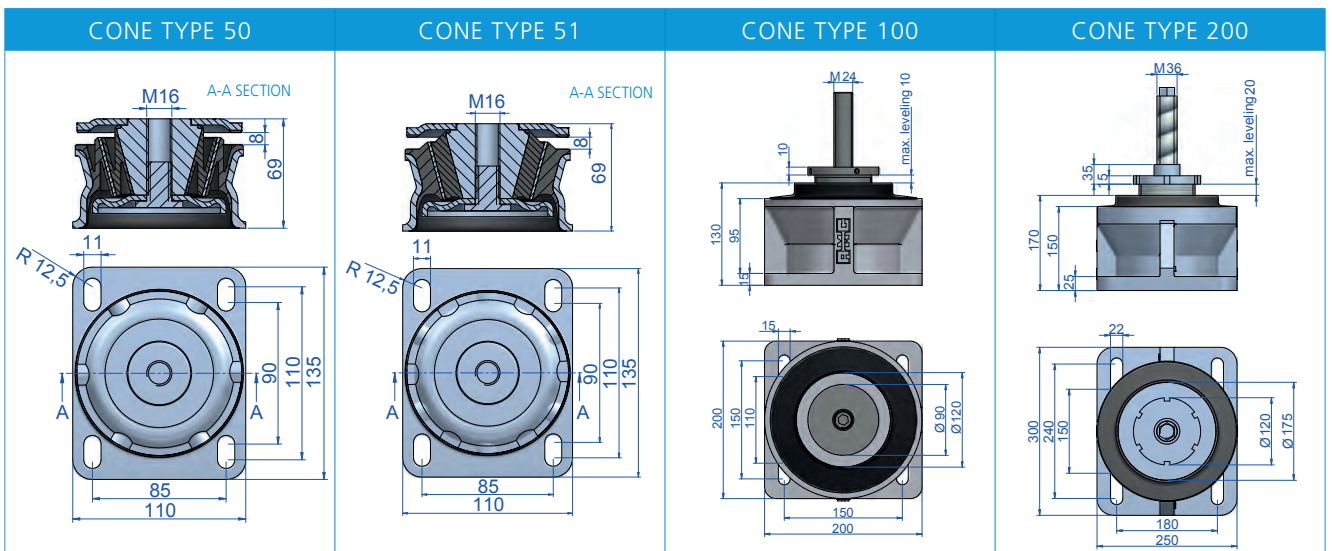

NATURAL FREQUENCY - AMC MECANOCACHO®
CONE WITH FIXATION FLANGE

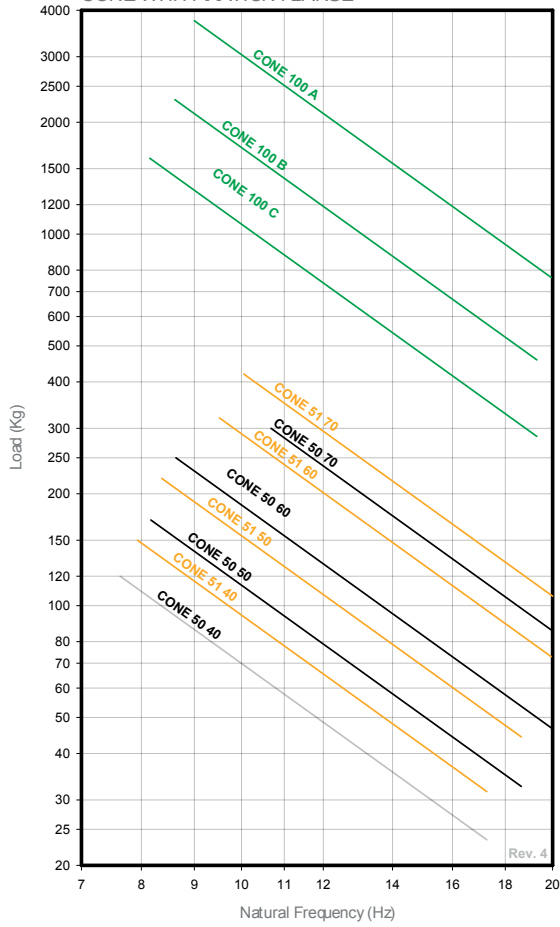

LOAD DEFLECTION GRAPH- AMC MECANOCACHO®
CONES WITH FIXATION FLANGE

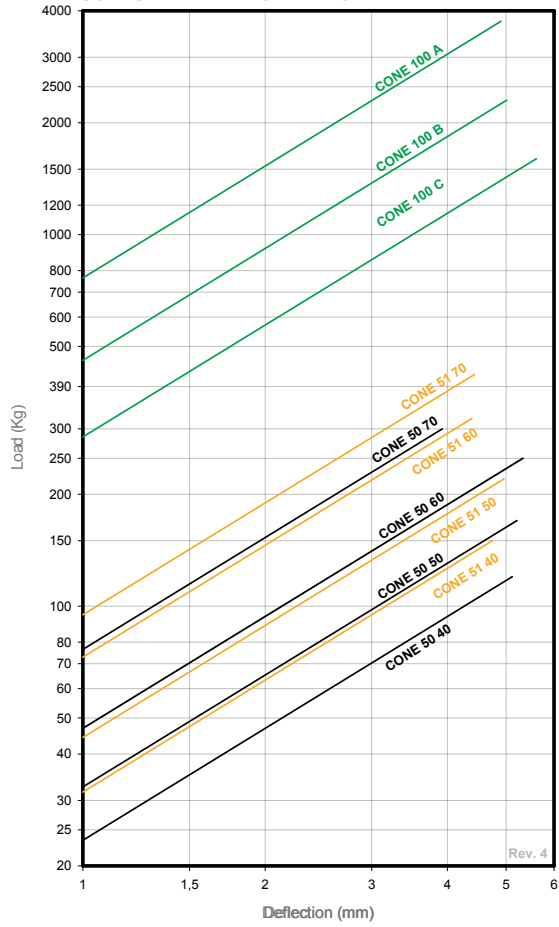

NATURAL FREQUENCY - AMC MECANOCACHO®
CONE 200 WITH FIXATION FLANGE

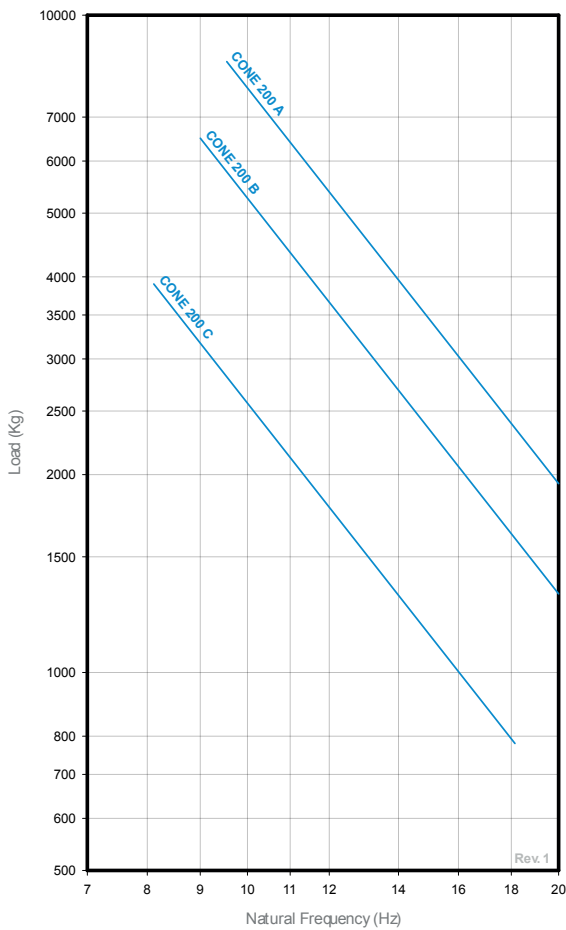

LOAD DEFLECTION GRAPH- AMC MECANOCACHO®
CONE 200 WITH FIXATION FLANGE

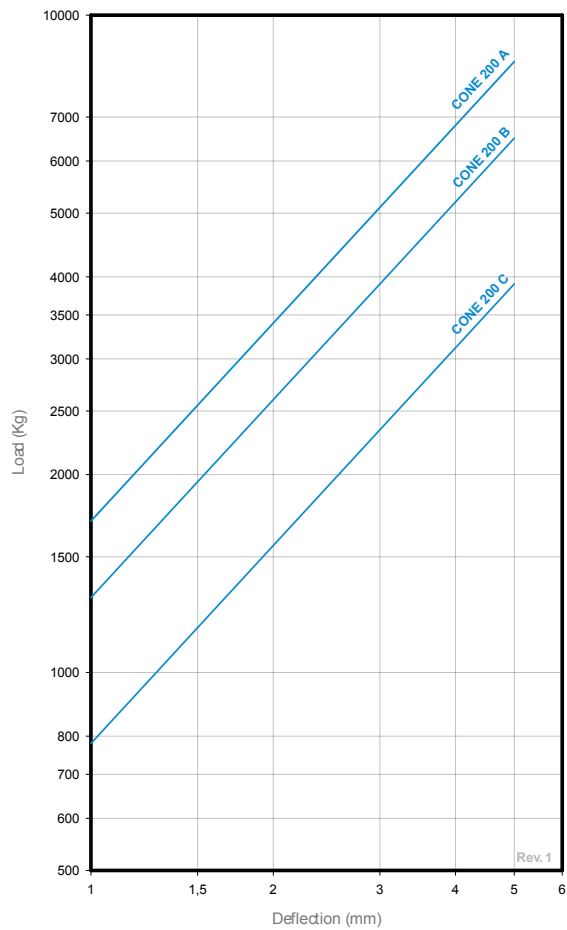

CABIN MOUNT



DESCRIPTION

The AMC MECANOCAUCHO® cabin mount is composed of two main metal parts. Both metal parts are bonded to a high resilient rubber for optimum vibration isolation.

TECHNICAL CHARACTERISTICS

- This mount incorporates two bump shaped profiles in order to absorb dynamic loads or shocks. This feature is specially interesting for restricting the motion of the cabin under transient shocks.
- The metal parts are corrosion protected to cope with arduous environments on land or marine applications. RoHs compliant.
- The AMC MECANOCAUCHO® cabin mount can be manufactured in other different rubber compounds in order to be suitable for different weight of cabins.
- Our technical department can give the correct recommendation in order to overpass ROPS tests on construction equipment machinery.

APPLICATIONS

For the effective isolation of vibration and noise on cabins for the following purposes:

- Agricultural Tractors.
- Construction equipment machinery
- Off road vehicles.

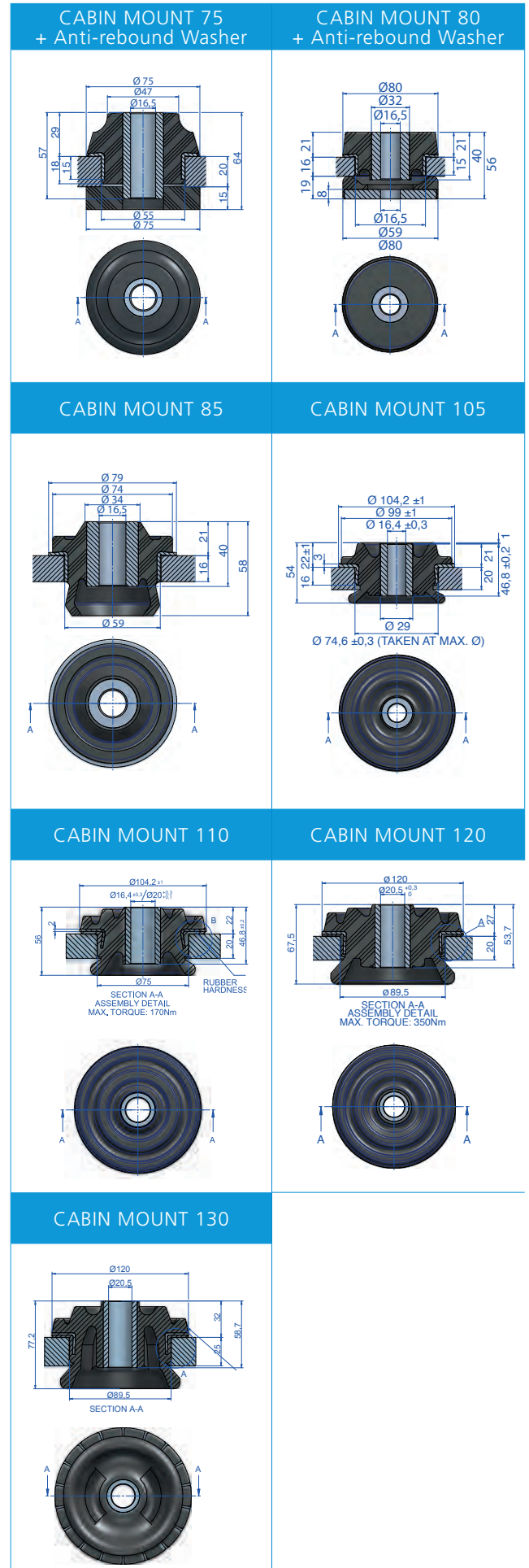
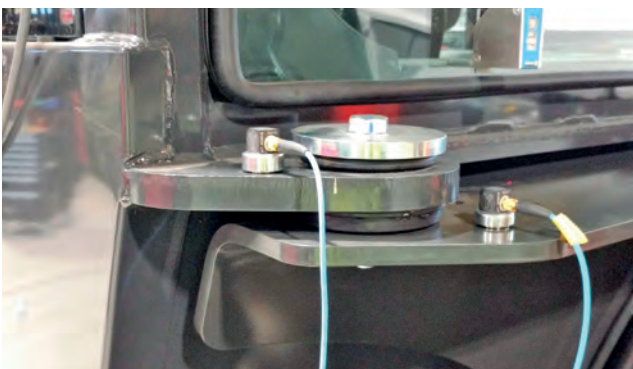

ANTI-VIBRATION MOUNTS

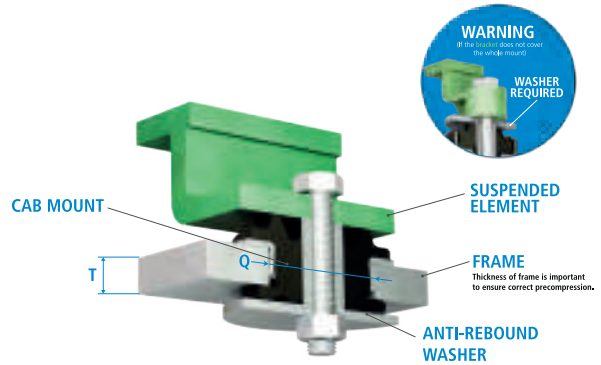
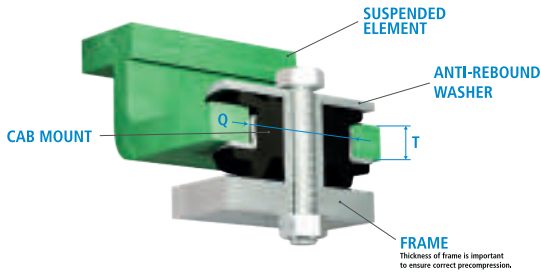

The anti-rebound washer is mandatory to be a Fail-Safe System. The thickness of the washer depends on the application. Please contact us, if you have any question.

Type	Q (mm)	T (mm)	Weight (gr)	Max. Load (kg)	Ø (mm)	Shore	Code
Cabin Mount 75	55,5	20	328	140	16	45 Sh	137371
				220	16	60 Sh	137372
				140	20	45 Sh	137373
				220	20	60 Sh	137374
Cabin Mount 80	60	16	616	200	16	50 Sh	137353
				300	16	60 Sh	137354
				200	20	50 Sh	137351
				300	20	60 Sh	137352
Cabin Mount 85	60	16	300	75	16	45 Sh	137322
				150	16	60 Sh	137323
				75	20	45 Sh	137313
				150	20	60 Sh	137311
Cabin Mount 105	75	20	600	190	16	45 Sh	137301
				250	16	50 Sh	137318
				350	16	60 Sh	137315
				190	20	45 Sh	137302
Cabin Mount 110	75	20	550	250	20	50 Sh	137320
				350	20	60 Sh	137319
				190	16	45sh	137304
				250	16	50sh	137305
Cabin Mount 120	89	20	660	350	16	60sh	137306
				450	16	70sh	137307
				250	20	50sh	137392
Cabin Mount 130	89	25	670	300	20	50sh	137441

Type	Washer	Ø (mm)	Weight (gr)	Øext (mm)	Øint (mm)	Thickness (mm)	Code
Cabin Mount 75	Anti rebound washer	16	170	76	16,5	5	608074
	Compression	20	155	76	20,5	5	610027
	Limiting Washer	16	170	76	16,5	5	608074
Cabin Mount 80	Compression	16	237	90	18	5	606482
	Limiting Washer	20	236	90	20,5	5	606486
	Anti rebound washer	16	237	90	18	5	606482
Cabin Mount 85	Compression	20	236	90	20,5	5	606486
	Limiting Washer	16	237	90	18	5	606482
	Anti rebound washer	20	236	90	20,5	5	606486
Cabin Mount 105	Compression	16	356	110	16,5	5	611167
	Limiting Washer	20	361	110	20,5	5	606487
	Anti rebound washer	16	356	110	16,5	5	611167
Cabin Mount 110	Compression	20	361	110	20,5	5	606487
	Limiting Washer	16	356	110	16,5	5	611167
	Anti rebound washer	20	361	110	20,5	5	606487
Cabin Mount 120	Compression	16	356	110	16,5	5	611167
	Limiting Washer	20	361	110	20,5	5	606487
	Anti rebound washer	20	358	120	20,5	5	610255
Cabin Mount 130	Compression	20	358	120	20,5	5	610249
	Limiting Washer	20	358	120	20,5	5	610255
	Anti rebound washer	20	358	120	20,5	5	610255

NATURAL FREQUENCY GRAPHS
AMC MECANOCAUCHO® CAB MOUNT

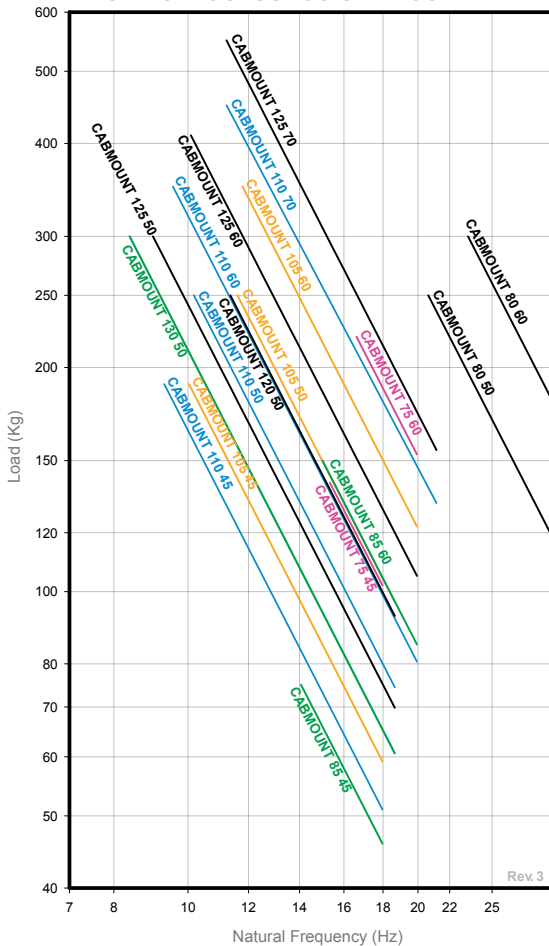

LOAD DEFLECTION GRAPHS
AMC MECANOCAUCHO® CAB MOUNT

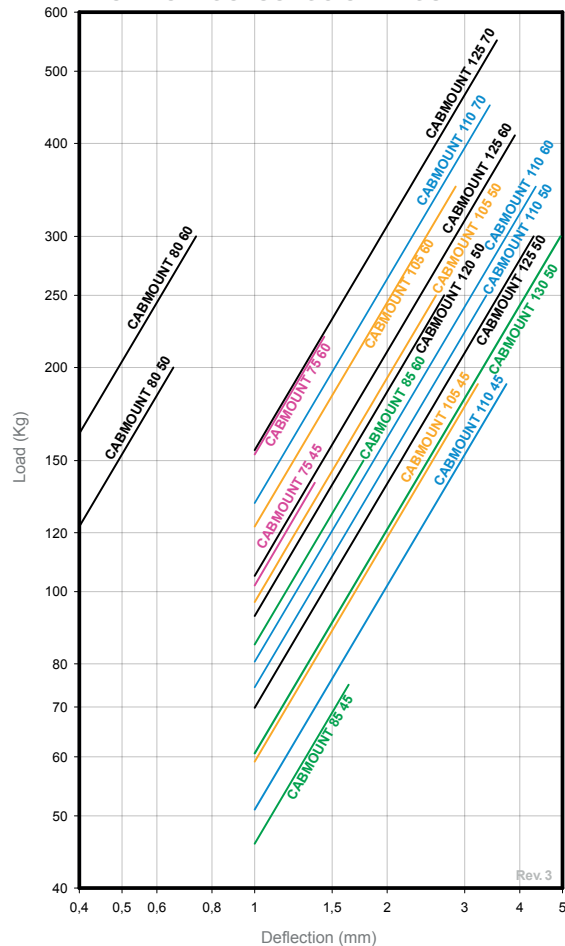

* AMC S.A. reserves the right to modify the design and manufacture of the materials presented in this catalogue without prior notice.

CB



DESCRIPTION

The AMC MECANOCAUCHO® type CB mounts are installed in pairs. Installation is simplified as both mounts fixed with one through bolt and a washers at each end.

The mount is provided with a built in wear plate that prevents the elastomeric element from coming in contact with sharp edges of support frames or structures that may cause friction in traditionally used semi bonded mounts. Therefore with these mounts there is no need to machine radii or chamfer holes.

The specific design of the mounts permits high dynamic loads whilst limiting the movement due to the multiple axial snubbing design.

TECHNICAL CHARACTERISTICS

- The AMC MECANOCAUCHO® Type CB is radially 30% softer than axially. This feature is specially interesting for those machines or equipments where radial axis vibration isolation is important.
- The mount is provided with a built in snubbing system that allows the following elastical courses:
 - Vertical: +/- 6 mm
 - Horizontal: +/- 3mm
- The mount can be supplied in two different sizes and in different hardness compounds to accommodate applications from 30 to 550 Kg per mount.
- Metal parts are embedded in rubber in order to prevent corrosion.

APPLICATIONS

- Agricultural or construction equipment cabins, engines, radiators, transmission, battery boxes.
- Marine equipment
- Mobile Generators or compressors.
- Chassis frames for Military, Bus, Truck, Motorhome and Emergency vehicles.



Blue colour: Stiffness ratios per axis.

Red colour: Maximum elastical course per axis.

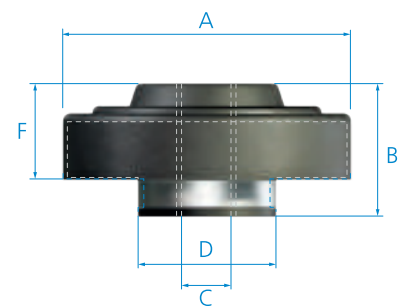
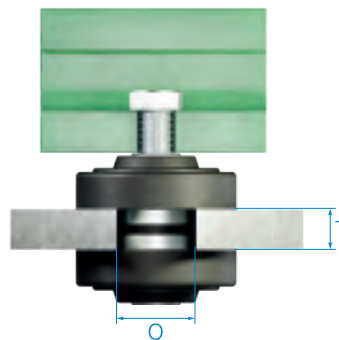
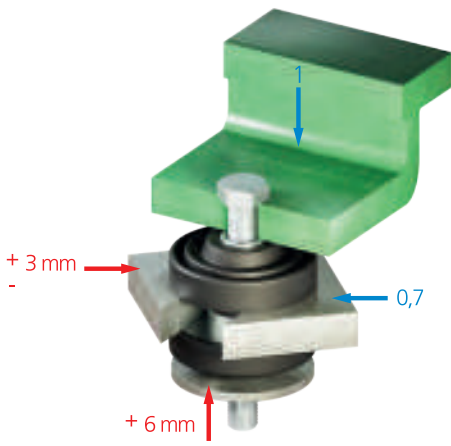

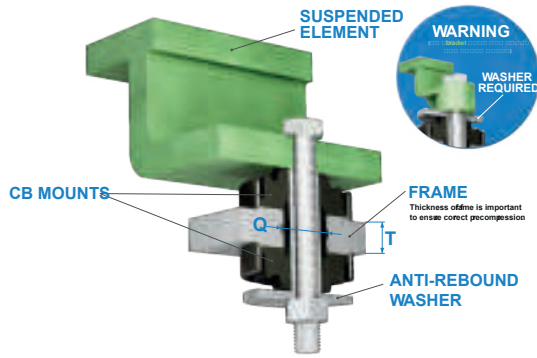
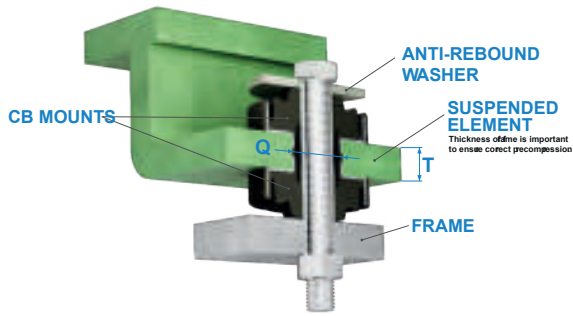

The anti-rebound washer is mandatory to be a Fail-Safe System. The thickness of the washer depends on the application. Please contact us, if you have any question.

Type	A (mm)	B (mm)	C (mm)	D (mm)	E (mm)	Q (mm)	T Max. (mm)	T Min. (mm)	Weight (gr)	Bolt size (metric)	Bolt size (imperial)	Shore	Max. Load (kg)	Code	Type	Weight (gr.)	Øext (mm)	Øint (mm)	Thickness (mm)	Code
CB 40	40	19	8,5	26	17	26	5	5	30	M8	5/16"	45Sh	8	156070	CB 40 WASHER	16	38	8,5	2	610053
												55Sh	18	156071						
												65Sh	25	156072						
CB 60	66	37	16,5	39,5	27,3	40	20	20	140	M16	5/8"	45 Sh	70	156011	CB 60 WASHER	125	66	16,5	5	606130
												55 Sh	120	156013						
												65 Sh	170	156014						
CB 65	65,5	38	18,9	40,5	29	41	20	20	175	M18	11/16"	45 Sh	70	156031	CB 65 WASHER	141	67	18,5	5	706004
												55 Sh	120	156032						
												65 Sh	170	156033						
CB 76	78,5	40	16,5	48	33	49	15	15	223	M16	5/8"	45 Sh	60	156053	CB 76 WASHER	175	76	16,5	5	608074
												55 Sh	90	156054						
												65 Sh	150	156055						
CB 80	78,5	42,5	16,5	37,9	32,5	38	20	18	242	M16	5/8"	45 Sh	200	156056	CB 80 WASHER	175	76	16,5	5	608074
												55 Sh	90	156001						
												65 Sh	200	156002						
CB 110	109	52	22,5	56,8	40	57	25	25	630	M22 M20	7/8" 3/4"	45 Sh	235	156021	CB 110 WASHER	286	110	23	5	610192
												55 Sh	375	156022						
												65 Sh	550	156023						
CB 125	127	57,5	24,5	71	43	71	40	40	1000	M24	15/16"	55 Sh	500	156089	CB 125 WASHER	1233	145	24,5	10	608529
												75 Sh	800	156090						
												70 Sh	800	156029						
CB 130	127	57,5	30,5	70,5	43	71	40	40	1200	M30	1 1/8"	45 Sh	325	156026	CB 130 WASHER	1233	145	30,5	10	608278
												55 Sh	500	156027						
												65 Sh	600	156028						
CB 150	148	69,5	33	89,5	51,5	90	40	40	1783	M30	1 1/8"	45 Sh	700	156065	CB 150 WASHER	1233	145	30,5	10	608278
												55 Sh	1000	156066						
												65 Sh	1800	156067						
												70 Sh	2000	156068						

NATURAL FREQUENCY AMC MECANOCAUCHO®
CB ANTI VIBRATION MOUNTS

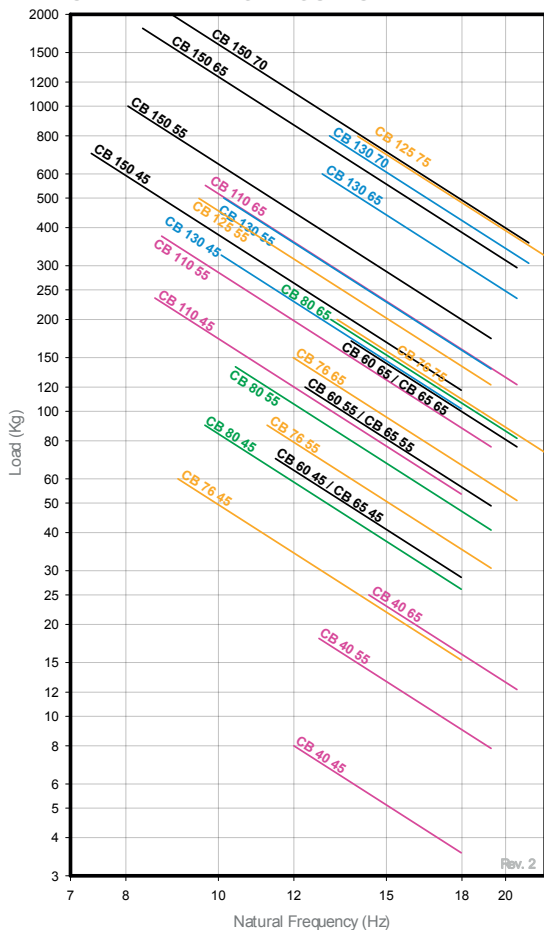

LOAD DEFLECTION GRAPH AMC MECANOCAUCHO®
CB ANTI VIBRATION MOUNTS

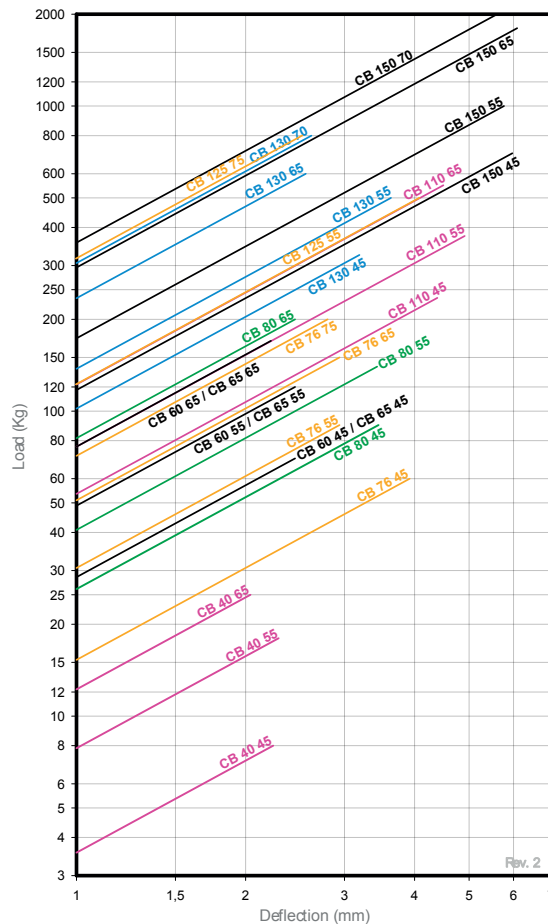

TF



DESCRIPTION

The AMC MECANOCAUCHO® TF type anti vibration mounts are made of two moulded parts. One of circular fully moulded rubber, and one circular part which is fully bonded to a centre tube which acts as a guide for the machine anchoring bolt. They are installed pre-compressed on the actual machine frame, whose thickness "E" determines the degree of pre-compression of the assembly.

TECHNICAL CHARACTERISTICS

This antivibration mount is ideal for applications with major dynamic loadings such as; Off-Road Construction vehicles for engines, gearboxes, Operator Cabins where movement control is necessary. It also offers optimal stability, as well as good attenuation of impacts and high frequency vibrations.

ASSEMBLY INSTRUCTIONS

The TF mounts should be assembled according to the following installation instructions. There are two possible configurations, see assembly 1 and assembly 2, for which the recommendations given in the following chart must be observed. They can be installed in plates of different thicknesses according to the T_{mx} and T_{min} values given in the Table provided. The Load vs Deformation curves will vary according to the plate thickness in which the mount will be installed.

APPLICATIONS

- Vehicle cabins
- Construction equipment machinery and agricultural vehicles, etc.

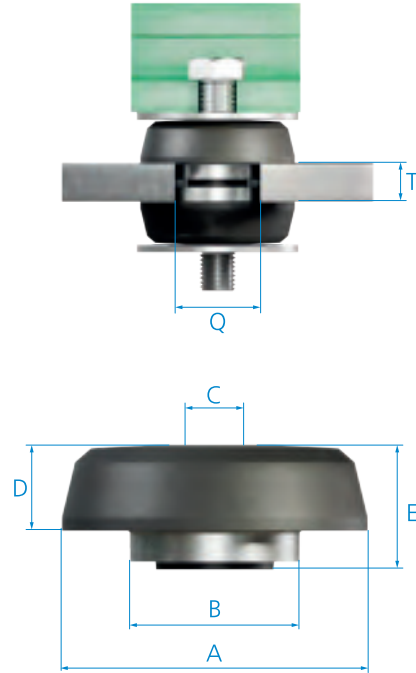

ANTI-VIBRATION MOUNTS

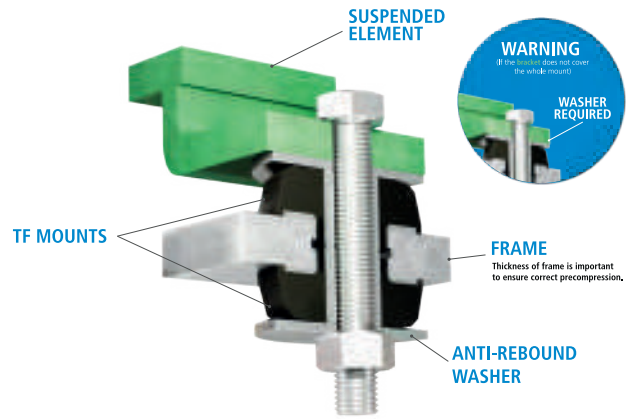
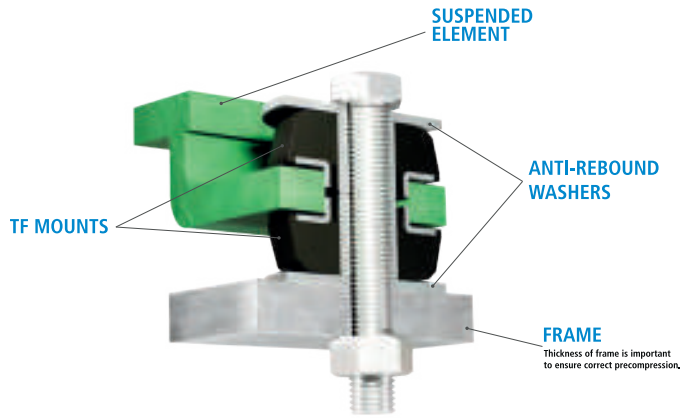

Washers should be used, if the rubber surface is not covered with the contact surface. Washers upon request.

Type	A (mm)	B (mm)	C (mm)	D (mm)	E (mm)	Q (mm)	T (mm)	Code	Shore	Max. Load (kg)	Type	Code	Øext (mm)	Øint (mm)	Thickness (mm)
TF 55	56,5	39,4	16,2	16	20	40	10	138061	45 Sh	80	TF 55 Washer	611056	54	17	3
								138063	60 Sh	175					
								137365	40 Sh	190					
TF 100	100	55,5	24,2	29,5	40,2	56	25	137366	50 Sh	280	TF 100 Washer	606484	110	24,5	5
								137363	60 Sh	390					
								137364	70 Sh	800					
								137381	40 Sh	160					
TF 105	105	74,6	16,2	30	38	75	20	137382	50 Sh	200	TF 105 Washer	606481	105	18	5
								137383	60 Sh	275					
								137384	70 Sh	360					
								137445	40 Sh	2000					
TF 150	146	79,5	24,5	54	71	79,5	35	137446	50 Sh	2500	TF 150 Washer	610379	150	24,5	10
								137447	60 Sh	3000					
								137448	70 Sh	4000					
								138151	60 Sh	1700					
TF 180	180	70	23	73	86	71	30	138151	60 Sh	1700	TF 180 Washer	610383	200	20,5	10

NATURAL FREQUENCY GRAPHS
AMC MECANOCAUCHO® TF

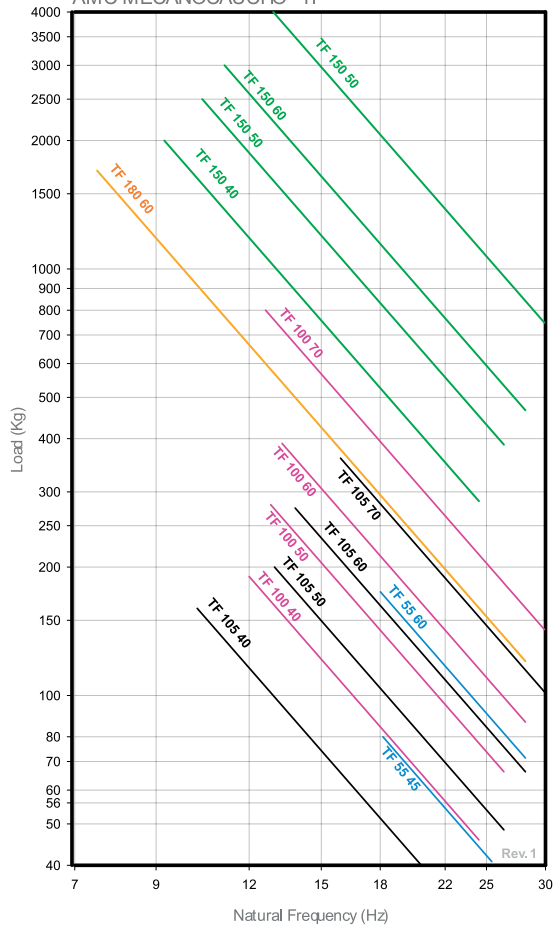

LOAD DEFLECTION GRAPHS
AMC MECANOCAUCHO® TF

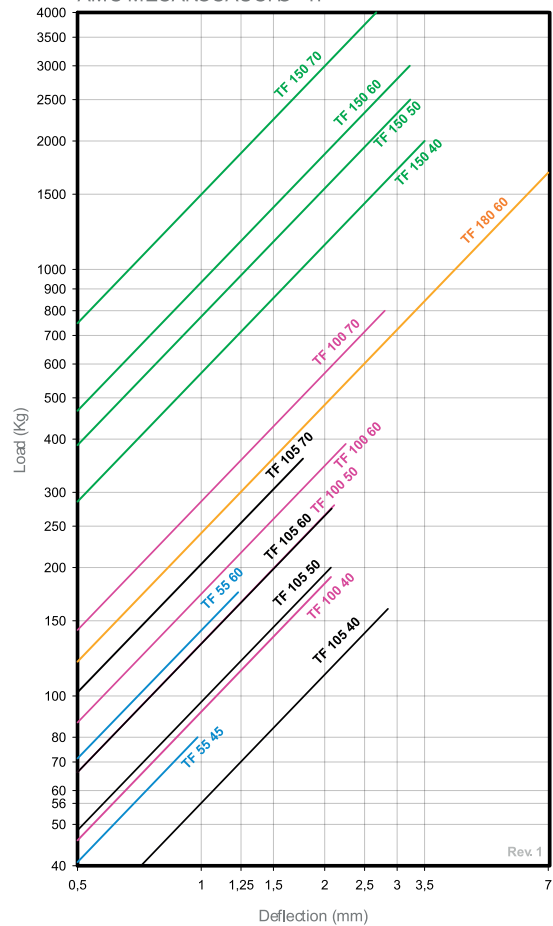

* AMC S.A. reserves the right to modify the design and manufacture of the materials presented in this catalogue without prior notice.



SCH

DESCRIPTION

The AMC MECANOCAUCHO® SCH type mounts are made of two parts of rubber, one of which bears an inside metal bushing which acts as a guide through the machine anchoring screw.

It is installed pre-compressed on the actual machine frame, whose thickness "T" determines the degree of precompression.

TECHNICAL CHARACTERISTICS

This antivibration mount is ideal for applications of major dynamic loads where movement control is necessary, such as in the cabins of all types of mobile vehicles. It also offers optimal stability, as well as good attenuation of impacts and vibrations.

APPLICATIONS

- Vehicle cabins.
- Public works and agricultural vehicles, etc.

ASSEMBLY INSTRUCTIONS

The SCH mounts should be assembled according to the following installation instructions. There are two possible configurations, see assembly 1 and assembly 2, for which the recommendations given in the following chart must be observed. They can be installed in plates of different thicknesses according to the T_{max} and T_{min} values given in the table at the bottom. The Load vs. Deformation curves will vary according to the thickness of the plate on which the mount is to be installed.



ASSEMBLY 1

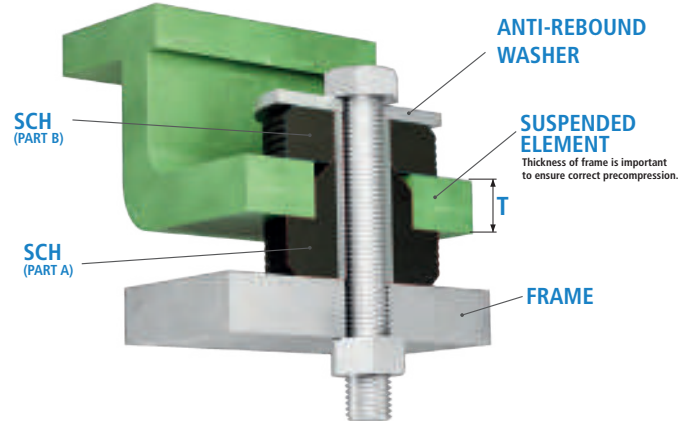

ASSEMBLY 2

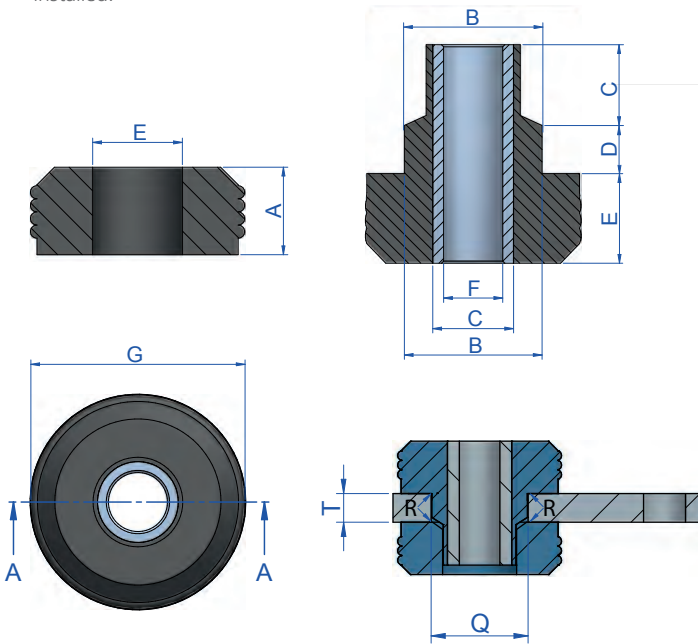
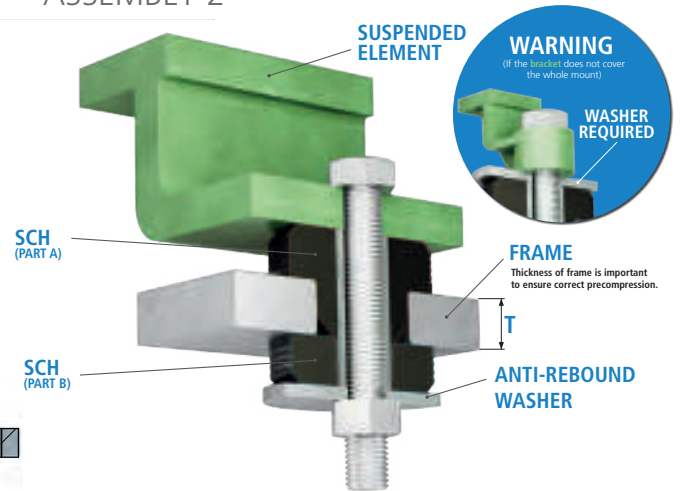

The anti-rebound washer is mandatory to be a Fail-Safe System. The thickness of the washer depends on the application. Please contact us, if you have any question.

Type	A (mm)	B (mm)	C (mm)	D (mm)	E (mm)	F (mm)	G (mm)	Q (mm)	T (Max.)	T (Min.)	Weight (gr.)	R (mm)	Code	Shore	Max.
SCH 35	11	20,1	11	4	11	8,1	33,5	19,1	6	6	94	1	138677	45 Sh	40
													138678	60 Sh	80
													138501	45 Sh	80
SCH 50	20	31	19,5	10,5	20	13,5	49	30,5	14	12,5	153	1,5	138504	60 Sh	130
													138522	75 Sh	210
													138502	45 Sh	120
SCH 65	23	39,5	24	15	23	17	63,5	38,5	22	19	350	2,5	138503	45 Sh	260
													138505	60 Sh	260
													138506	60 Sh	450
SCH 90	25	58	31	17	25	23	88	57	29	25	675	3	138514	50 Sh	650
													138515	60 Sh	800

Type	Code	Øext (mm)	Øint (mm)	Thickness (mm)
SCH 35 WASHER	610053	38	8,5	2
SCH 50 WASHER	611080	54	12,5	3
SCH 65 WASHER	606130	67	16,5	5
SCH 90 WASHER	608101	95	22	6
SCH 125 WASHER	610123	125	25	8



NATURAL FREQUENCY
AMC MECANOCAUCHO® SCH

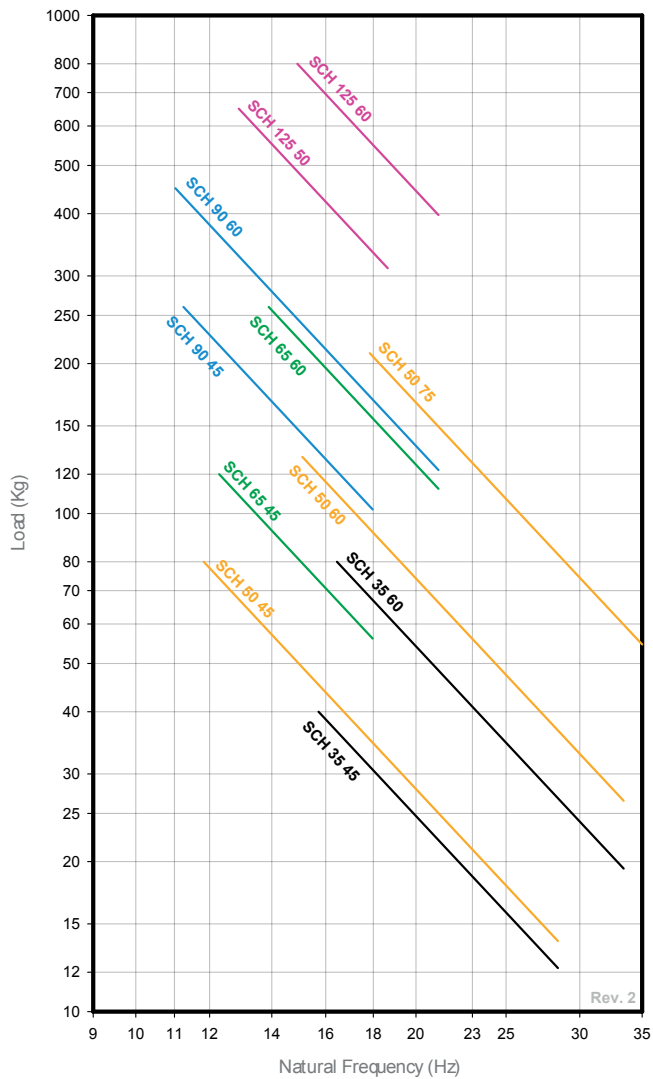

LOAD DEFLECTION GRAPH
AMC MECANOCAUCHO® SCH

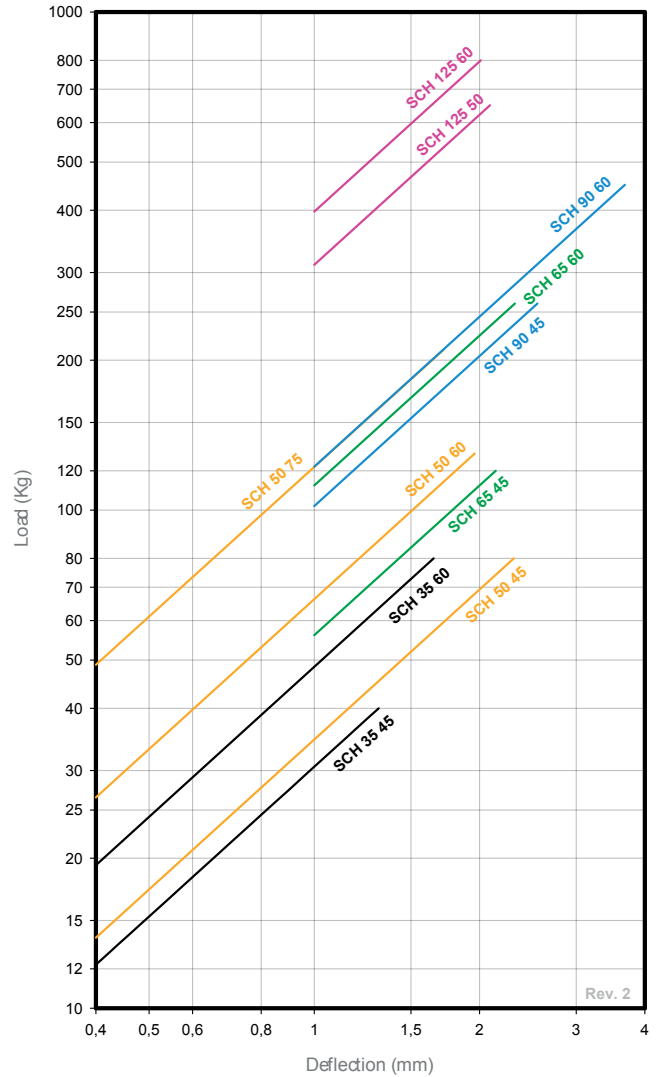

SCHR



DESCRIPTION

The AMC MECANOCAUCHO® SCHR type mounts are made of two parts of rubber, one of which bears an inside metal bushing which acts as a guide through the machine anchoring screw. It is installed pre-compressed on the actual machine frame, whose thickness "T" determines the degree of precompression.

Moreover it contains a metallic part, that avoids a premature wear by friction between the rubber and the housing of the mount.

TECHNICAL CHARACTERISTICS

This antivibration mount is ideal for applications of major dynamic loads where movement control is necessary, such as in the cabins of all types of mobile vehicles. It also offers optimal stability, as well as good attenuation of impacts and vibrations.

APPLICATIONS

- Vehicle cabins
- Public works and agricultural vehicles, etc.

ASSEMBLY INSTRUCTIONS

The SCHR mounts should be assembled according to the following installation instructions. There are two possible configurations, see assembly 1 and assembly 2, for which the recommendations given in the following chart must be observed. They can be installed in plates of different thicknesses according to the Tmax and Tmin values given in the table at the bottom. The Load vs. Deformation curves will vary according to the thickness of the plate on which the mount is to be installed.

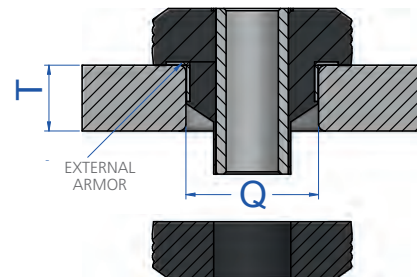
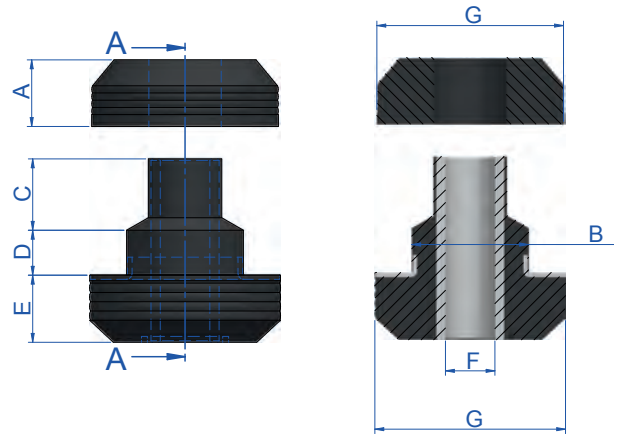

Type	A (mm)	B (mm)	C (mm)	D (mm)	E (mm)	F (mm)	G (mm)	Q (mm)	T (Max.)	T (Min.)	Weight (gr.)	Code	Shore	Max. Load (kg)
SCHR 35	11	20,1	11	4	11	8	34,5	20,4	6	6	42	138621	45 Sh	40
												138623	60 Sh	80
SCHR 50	20	31,7	19,5	10,5	20	13,5	49	31,8	14	12,5	153	138535	45 Sh	80
												138534	65 Sh	150
												138559	75 Sh	200
SCHR 65	23	39,5	24	15	23	16,75	64,5	40	22	19	269	138551	50 Sh	160
												138552	65 Sh	300
SCHR 90	25	56,5	31	17	25	23	88	57	29	25	675	138547	45 Sh	260
												138548	60 Sh	450
SCHR 125	32	65,4	32	22	32	27	125,5	65,8	32	25	1440	138216	50 Sh	650
												138217	60 Sh	800
SCHR 140	35	70	31	13	35	31	140	71	20	20	1900	138508	45 Sh	700
												138510	60 Sh	2000

Washers should be used, if the rubber surface is not covered with the contact surface.
Washers upon request.

Type	Code	Weight (kg)	Øext (mm)	Øint (mm)	Thickness (mm)
SCHR 35 Washer	610053	0,03	38	8,5	2
SCHR 50 Washer	611080	0,051	54	13,5	3
SCHR 65 Washer	606130	0,125	67	16,5	5
SCHR 90 Washer	608101	0,31	96	22	6
SCHR 125 Washer	610123	0,58	145	25	8
SCHR 140 Washer	608115	1,251	145	30	10

ASSEMBLY 1

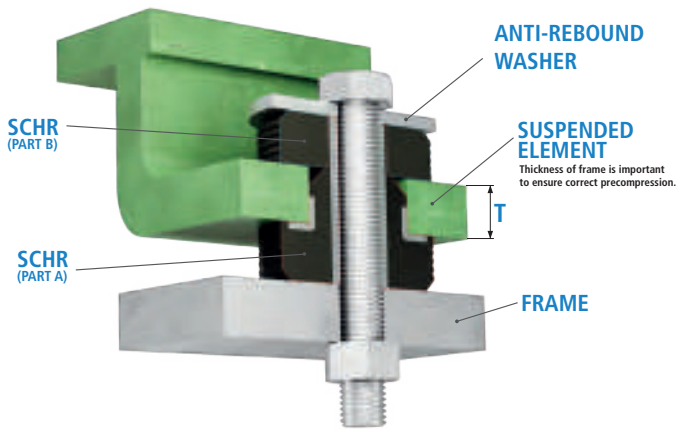

ASSEMBLY 2

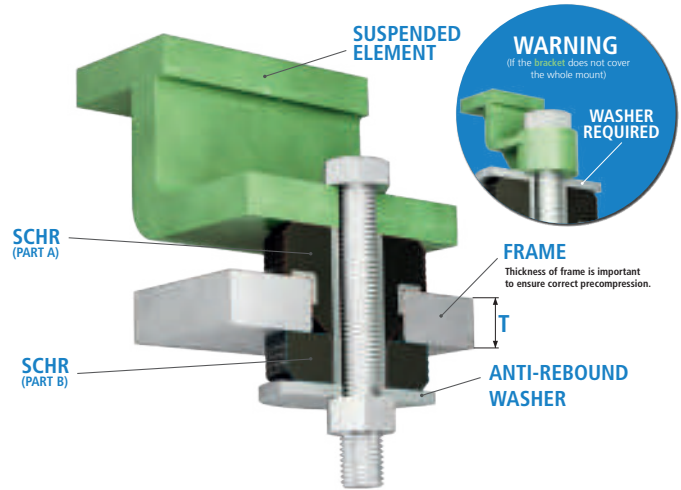

NATURAL FREQUENCY
AMC MECANOCAUCHO® SCHR

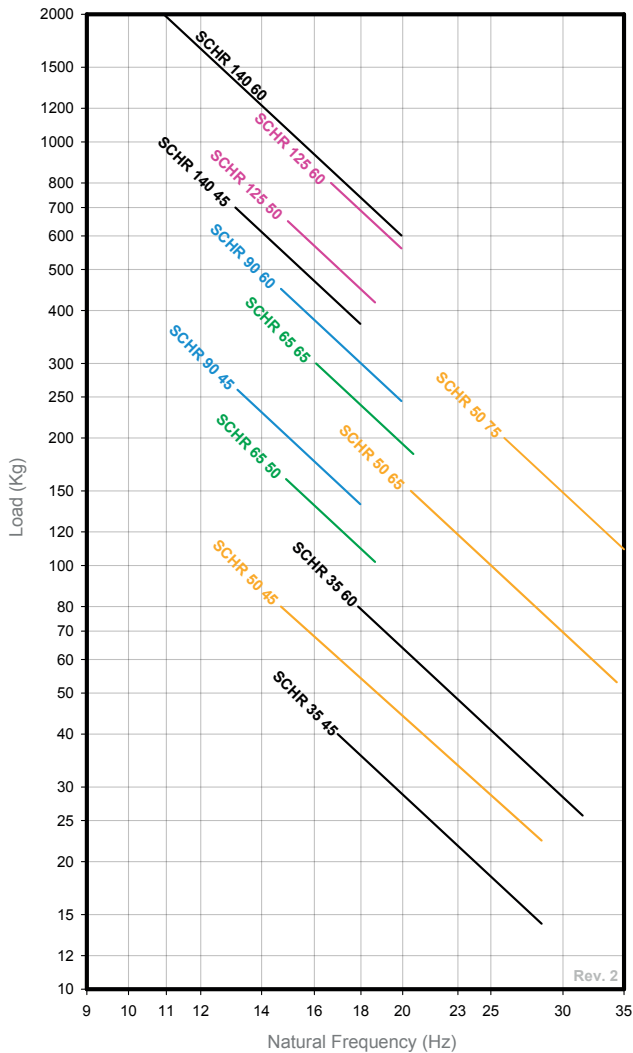

LOAD DEFLECTION GRAPH
AMC MECANOCAUCHO® SCHR

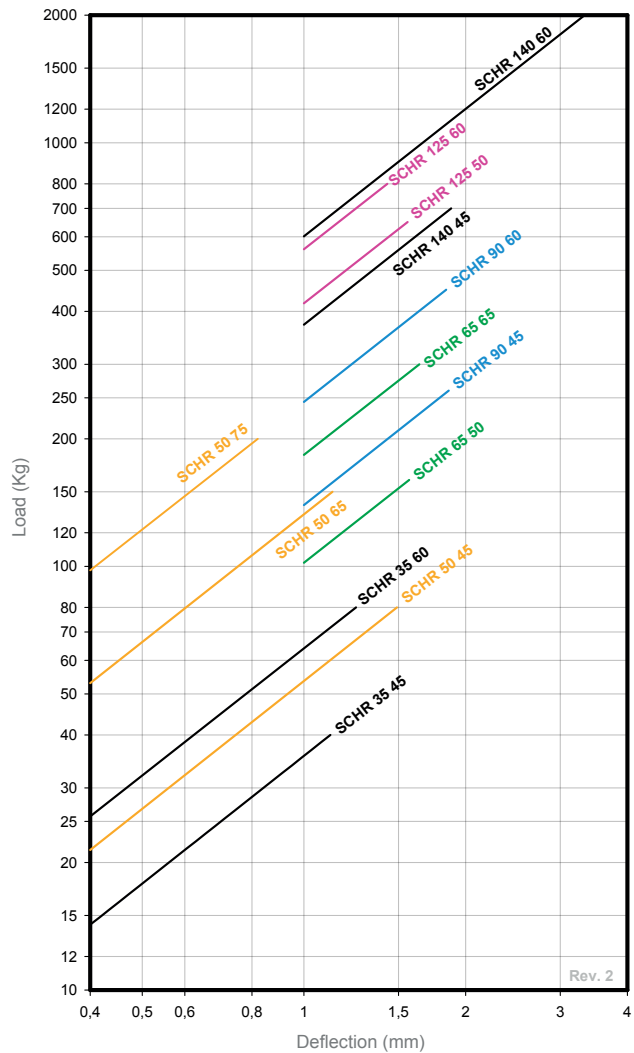

SCB



DESCRIPTION

The SCB elastic mounts are elements that work on the basis of compression since thanks to their design and assembly they provide an anti-rebound effect, thus permitting safety assemblies.

ADVANTAGES

- Easy to install
- Simple and economical product.
- Wide range of loads.

Their failsafe feature makes them very recommendable for mobile applications.

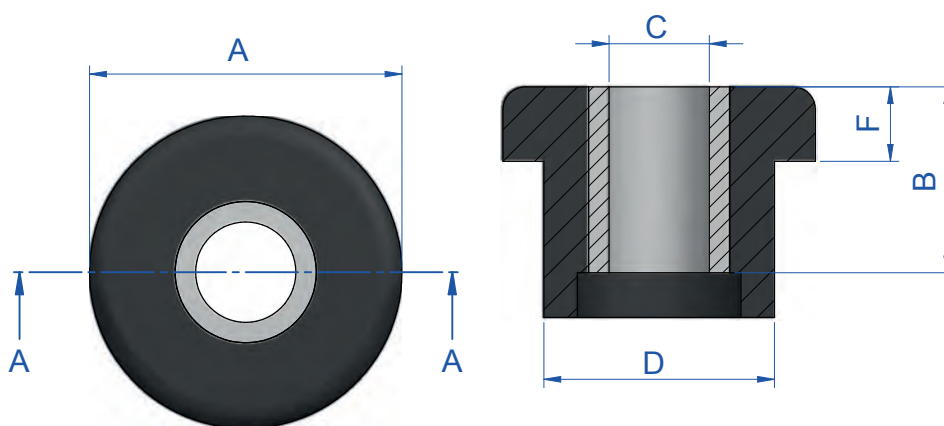

Washers should be used, if the rubber surface is not covered with the contact surface.
Washers upon request.

Type	A (mm)	B (mm)	C (mm)	D (mm)	F (mm)	Q (mm)	T (Max.) (mm)	T (Min.) (mm)	Weight (gr.)	R (mm)	Code	Load (kg)	Shore
SCB 20	27	15,5	10,25	20	7	19,5	5	4	20	1	138013	30	45 Sh
											138019	38	60 Sh
SCB 20i	27	15,5	8	20	7	19,5	5	4	20	1	138056	38	60 Sh
SCB 25	27,5	21	10	20	6,5	19,5	15	14	20	1	138001	50	60 Sh
SCB 35	27,5	12,5	8	19,4	8,5	19	4	3	30	0,5	138012	25	45 Sh
SCB 38	33,5	19	10,5	20,5	11	20,5	5	3	30	0,5	138043	50	60 Sh
											138044	80	75 Sh
SCB 40	35	15,5	13	26,5	8	26,5	5	4	50	1	138022	75	60 Sh
SCB 45	41,5	25,5	13,75	31	10	30	11	10	56	1,5	138002	100	60 Sh
SCB 50	49,5	35	13,5	34	13,5	33	17	16	73	1,5	138003	200	60 Sh
SCB 60	63	31,2	16,2	41	17	40	10	9	108	3	138004	250	60 Sh
SCB 65	62	43,5	16,5	40	17	39	20	19	140	3	138005	250	60 Sh
SCB 95	92	51,5	20,5	56	26,5	54,5	20	19	395	3	138011	1000	65 Sh

Type	Øext (mm)	Øint (mm)	Thickness (mm)	Code	Weight (kg)
SCB 20 WASHER	28	10,5	2	606185	0,03
SCB 20i WASHER	28	8,5	2	606124	0,03
SCB 25 WASHER	28	8,5	2	606124	0,03
SCB 35 WASHER	28	8,5	2	606124	0,03
SCB 38 WASHER	38	12,5	3	611065	0,04
SCB 40 WASHER	38	12,5	3	611065	0,04
SCB 45 WASHER	54	12,5	3	611080	0,051
SCB 50 WASHER	54	12,5	3	611080	0,051
SCB 60 WASHER	66	16,5	5	606130	0,125
SCB 65 WASHER	66	16,5	5	606130	0,125
SCB 95 WASHER	95	22	6	608101	0,31

ASSEMBLY

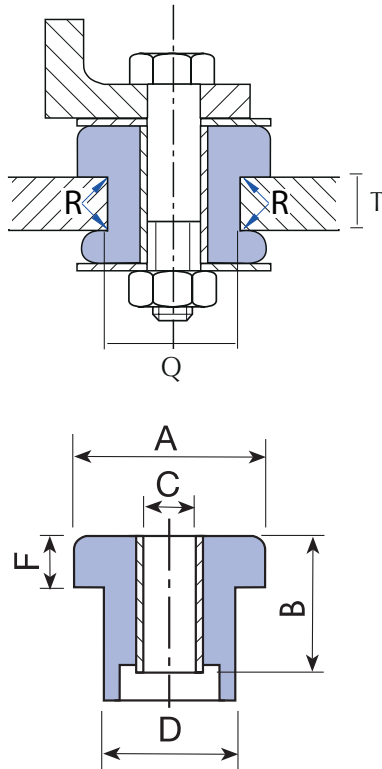

NATURAL FREQUENCY
AMC MECANOCAUCHO® SCB

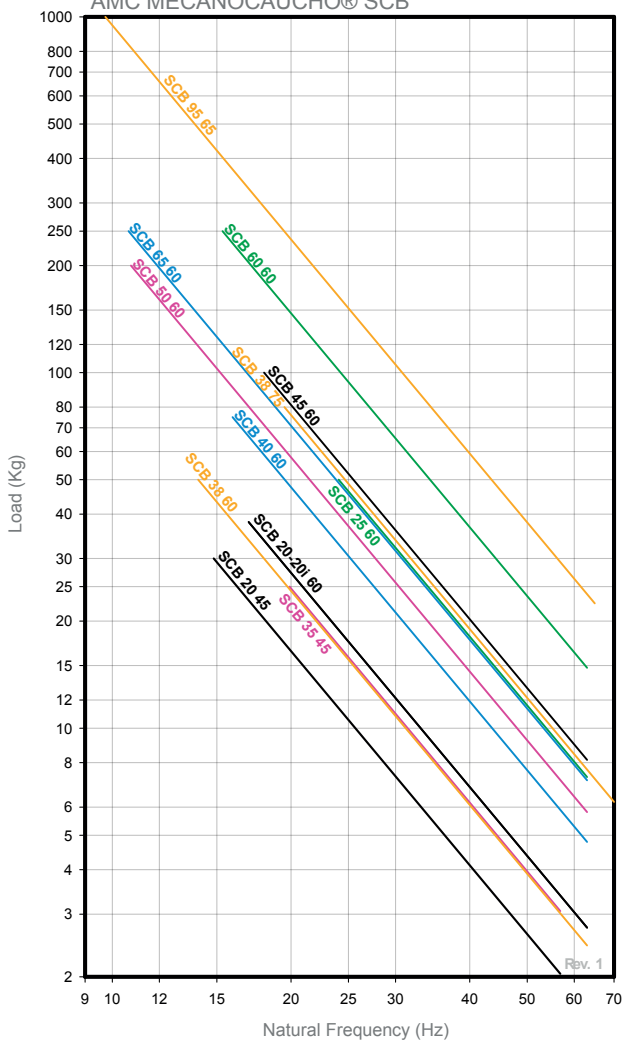

LOAD DEFLECTION GRAPH
AMC MECANOCAUCHO® SCB

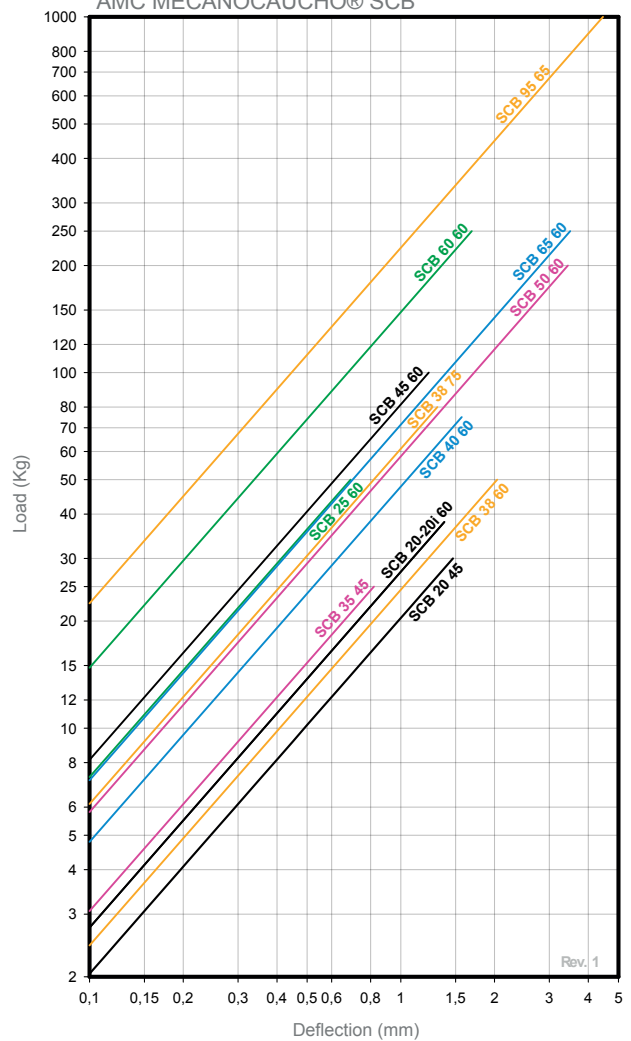

* AMC S.A. reserves the right to modify the design and manufacture of the materials presented in this catalogue without prior notice.

SCBR



DESCRIPTION

The SCBR elastic mounts are elements that work on the basis of compression since thanks to their design and assembly they provide an anti-rebound effect, thus permitting safety assemblies.

Moreover it contains a metallic part, that avoids a premature wear by friction between the rubber and the housing of the mount.

ADVANTAGES

The inside stop effect makes them very recommendable for safety purposes.

- Easy to assemble.
- Simple and economical product.
- Wide range of loads.

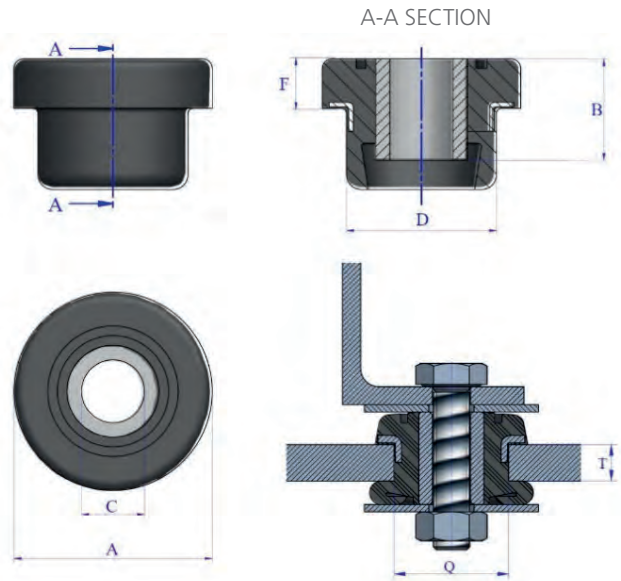

Washers should be used, if the rubber surface is not covered with the contact surface.
Washers upon request.

Type	A (mm)	B (mm)	C (mm)	D (mm)	F (mm)	Q (mm)	T (Max.)	T (Min.)	Weight (gr.)	Washer	Code	Load (kg)	Shore
SCBR 38	34	19	10,75	20,75	11	20,5	5	3	30	611065	138045	35	45 Sh
SCBR 42	42	21,25	13	31,5	9,5	31,5	6	6	40	611080	138051	75	60 Sh
SCBR 45	42	25,5	10,5	31,5	10	30	11	10	56	611080	138027	100	60 Sh

Type	Øext (mm)	Øint (mm)	Thickness (mm)	Code	Weight (kg)
SCB 38 WASHER	38	12,5	3	611065	0,04
SCB 42 WASHER	54	12,5	3	611080	0,051
SCB 45 WASHER	54	12,5	3	611080	0,051

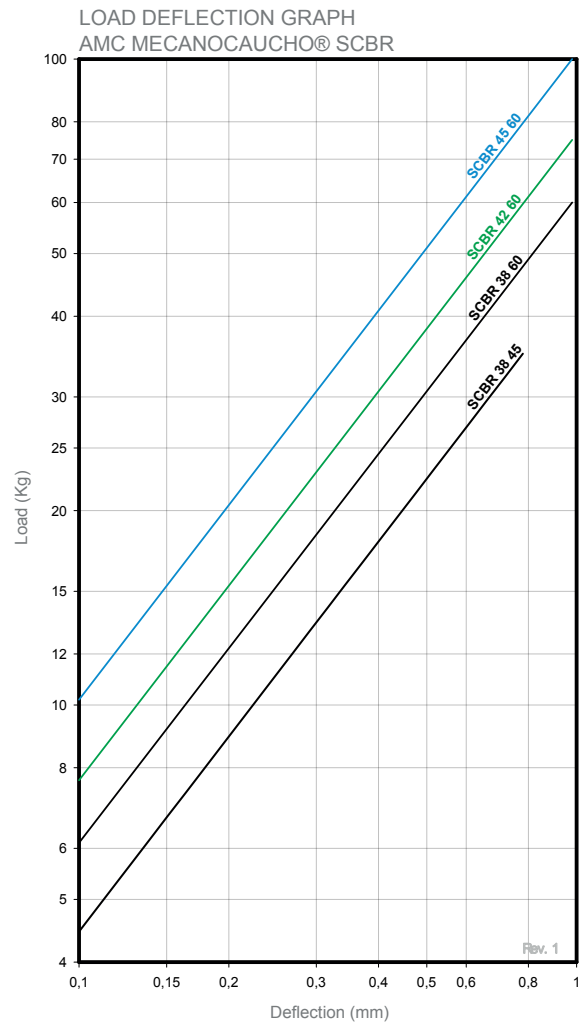
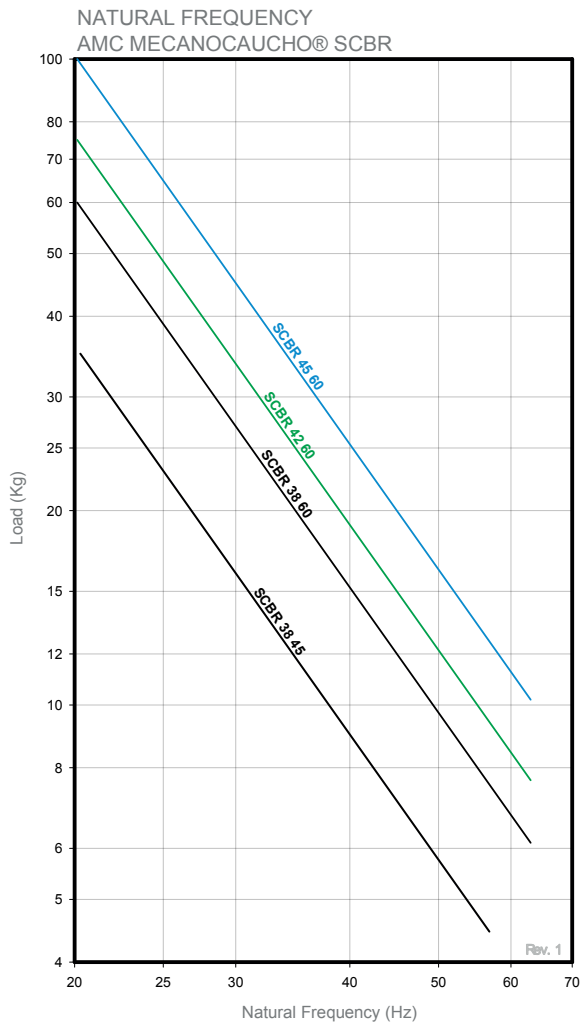

VD



DESCRIPTION

The AMC MECANOCAUCHO® mount works the elastomer at shear-compression. It is comprised of 2 metal parts which allow it to be installed with its two built-in screws.

TECHNICAL CHARACTERISTICS

The type VD is a vee shaped mount providing high deflections for relatively low loads. This means that the natural frequency is low and ideal for engines which normally run at idle speed.

It has three different stiffness rates X,Y,Z which permits adjustments of system modes for optimal isolation and stability.

They can be installed at specific angles providing further adjustment to the systems characteristics. For this purposes, please contact our technical department.

APPLICATIONS

It is used in applications where the load of the suspended unit is low and the level of vibration isolation must be high, such as:

- Small vehicles.
- Small and medium sized gen sets.
- Construction equipment machinery.

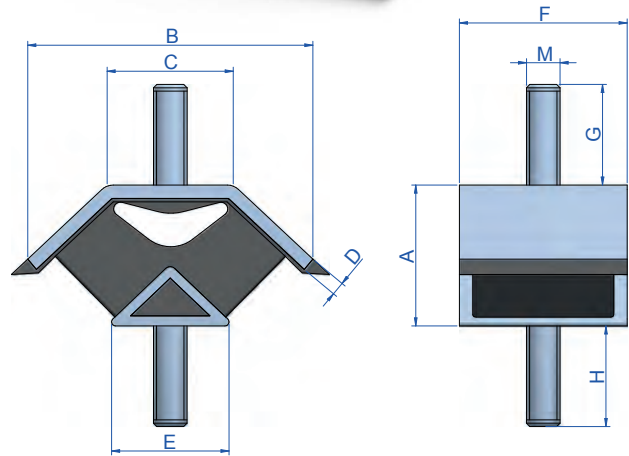

Type	A (mm)	B (mm)	C (mm)	D (mm)	E (mm)	F (mm)	G (mm)	H (mm)	M	Weight (gr.)	Code	Load (kg)
Small 40	41	95	39	4	35	50	23	25	M-10	330	148121	75
Small 45 M12	41	95	39	4	35	50	30	30	M-12	350	148132	90
Small 50	41	95	39	4	35	50	23	25	M-10	330	148123	100
Small 60	41	95	39	4	35	50	23	25	M-10	330	148125	110
Small 60 M12	41	95	39	4	35	50	30	31	M-12	350	148133	110
Medium 45	64	130	60	6	52	60	34	36	M-12	805	148101	100
Medium 50	64	130	60	6	52	60	34	36	M-12	805	148102	100
Medium 60	64	130	60	6	52	60	34	36	M-12	805	148104	150
Medium 70	64	130	60	6	52	60	34	36	M-12	805	148105	175

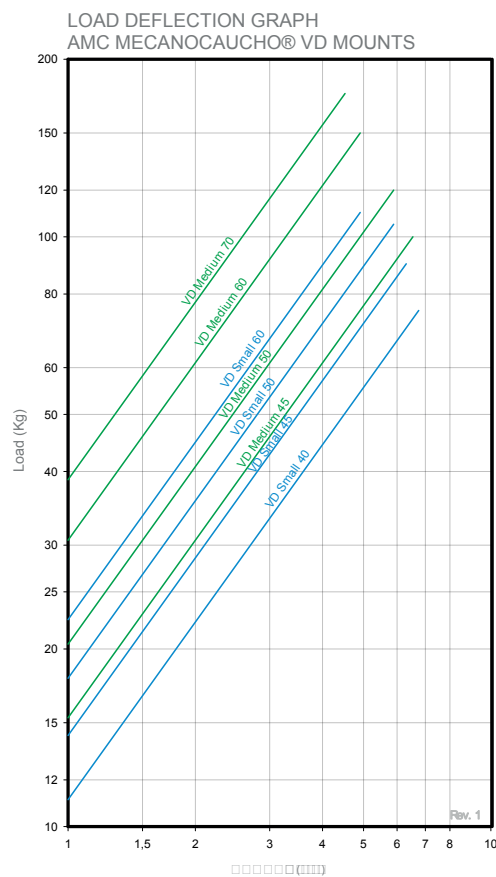
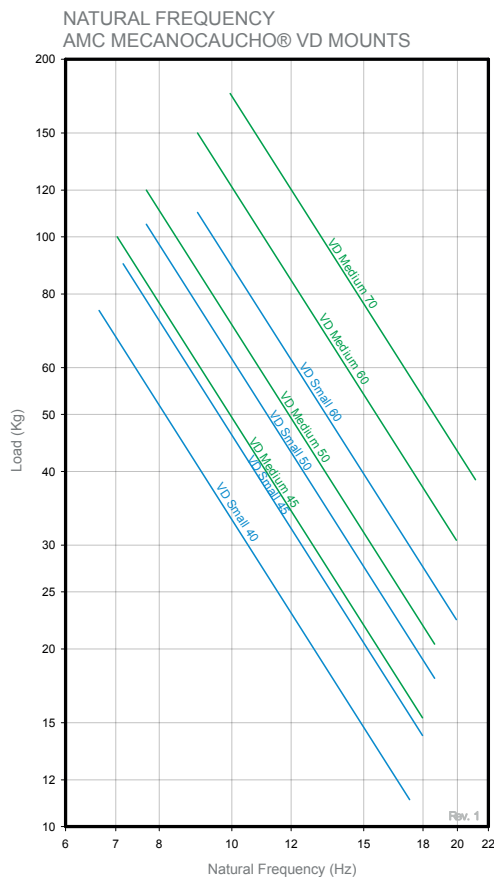

* AMC S.A. reserves the right to modify the design and manufacture of the materials presented in this catalogue without prior notice.

V-SHAPED MARINE TYPE



DESCRIPTION

The AMC MECANOCAUCHO® V-shaped marine mount works the rubber section in shear-compression. It is comprised of 2 metal parts which permit its installation by means of a screw at the top and two holes for securing it to the chassis.

TECHNICAL CHARACTERISTICS

The AMC MECANOCAUCHO® V-shaped marine mount has a V-shaped design providing high deflections for relatively low loads. This means that the natural frequency is low and ideal for engines which normally work at iddle speed.

It has three different stiffness rates X,Y,Z which permits adjustments of system modes for optimal isolation and stability.

APPLICATIONS

It is used in applications where the load of the suspended unit is low, and where high deflection is required to reach high vibration isolation levels.

Small vehicle or machines, small and medium sized gensets, marine engines,...

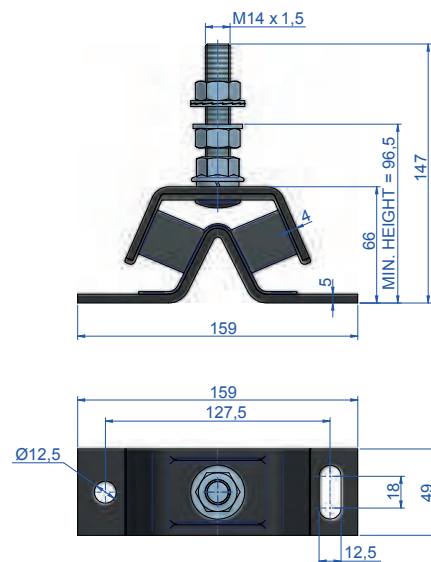
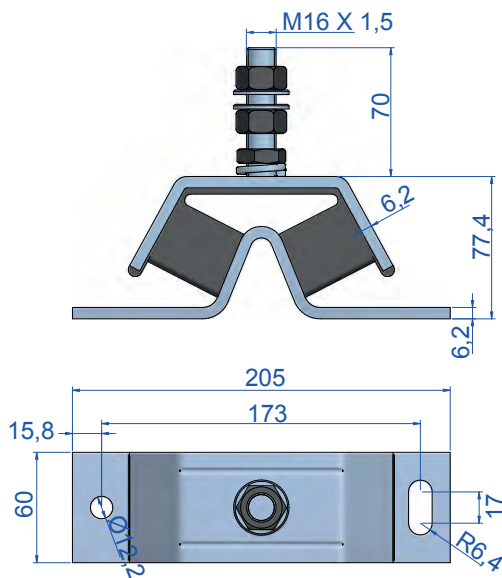

Type	Weight (gr.)	Code	Descrip.	Load (kg)	Shore
V-shaped marine	1720	148001	75	40	40 Sh
		148003	100	75	50 Sh
		148004	150	100	60 Sh
		148006	200	150	70 Sh
Small V-shaped marine	925	136279	50	40	
		136338	70	40	

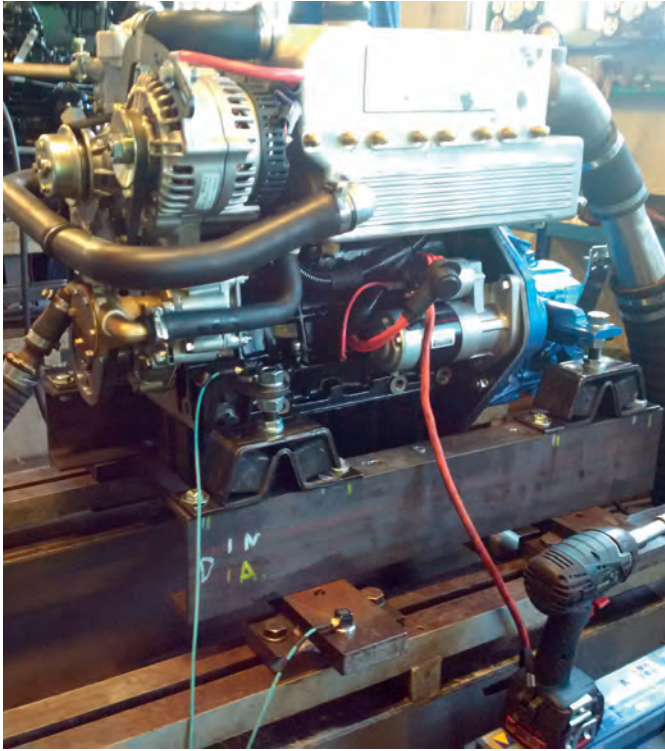

NATURAL FREQUENCY
AMC MECANOCAUCHO® V-SHAPED MARINE MOUNT

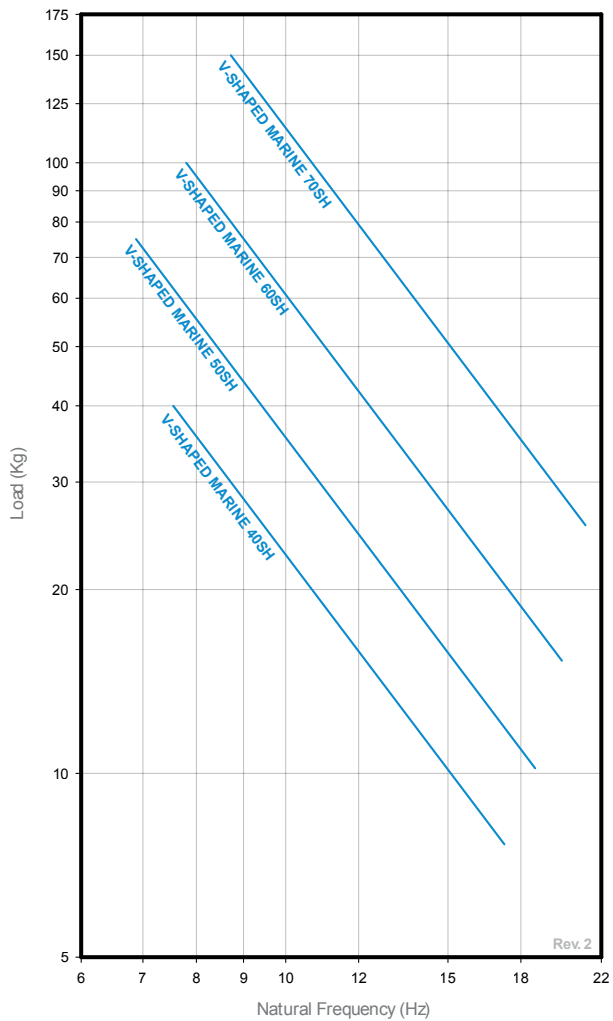

LOAD DEFLECTION GRAPH
AMC MECANOCAUCHO® V-SHAPED MARINE MOUNT

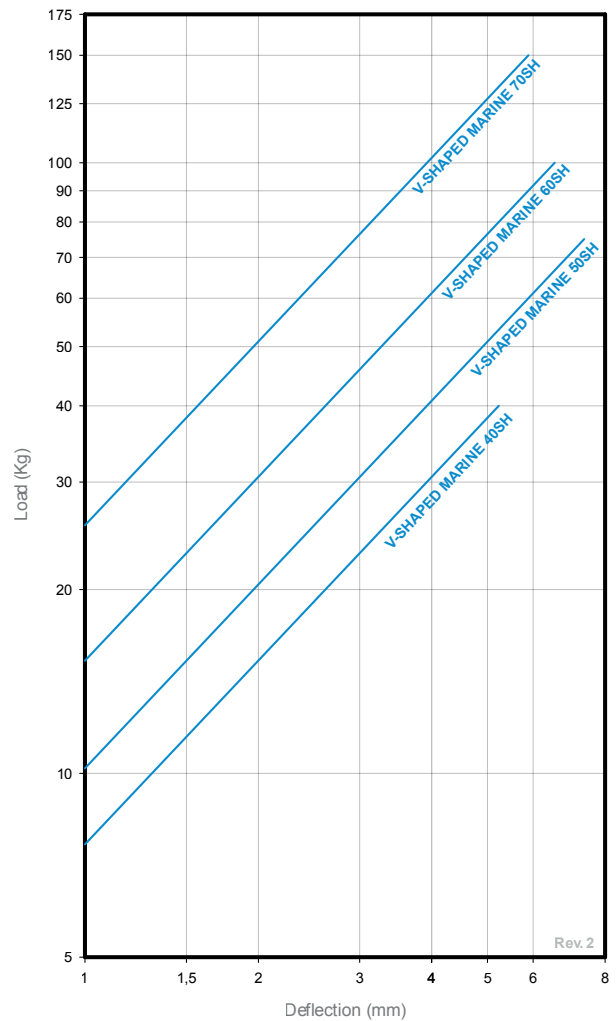



Type AN-60

The AMC-MECANOCAUCHO® anti vibration mounts type AN-60 have a specific design that allows suspensions with tunable traction indexes and compression rigidity. This feature is particularly useful in those applications where the vibration and transient forces come mainly in axial direction. The metal parts are robust and are designed with a specific groove that allows the supplementary AN-60 to be stacked.

The metal parts that make up this support are treated with Zinck Nickel coating. This characteristic allows them to have a high protection against the agents present in the exterior, such as the saline mist.



APPLICATIONS

AMC-MECANOCAUCHO® type AN-60 anti vibration mounts can be used from the suspension of vibratory equipment to Tune mass dampers or mobile applications that are exposed to compression and traction forces:

- The assembly on board of equipment on ships
- Railroads
- Road Transport
- Engines
- Pumps
- Generating sets

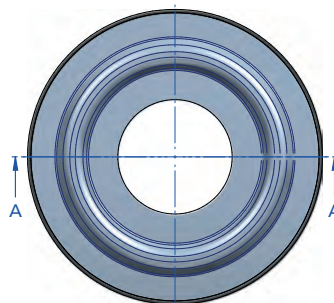
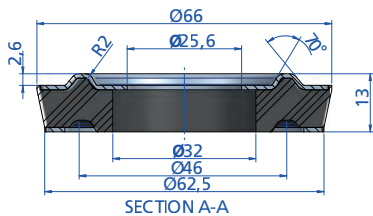

Type	Shore	Deflection (mm)	Weight (kg)	Max. Load (kg)	Code
AN-60	60Sh	1,8	0,05	700	180239

NATURAL FREQUENCY
AMC MECANOCAUCHD® AN 60

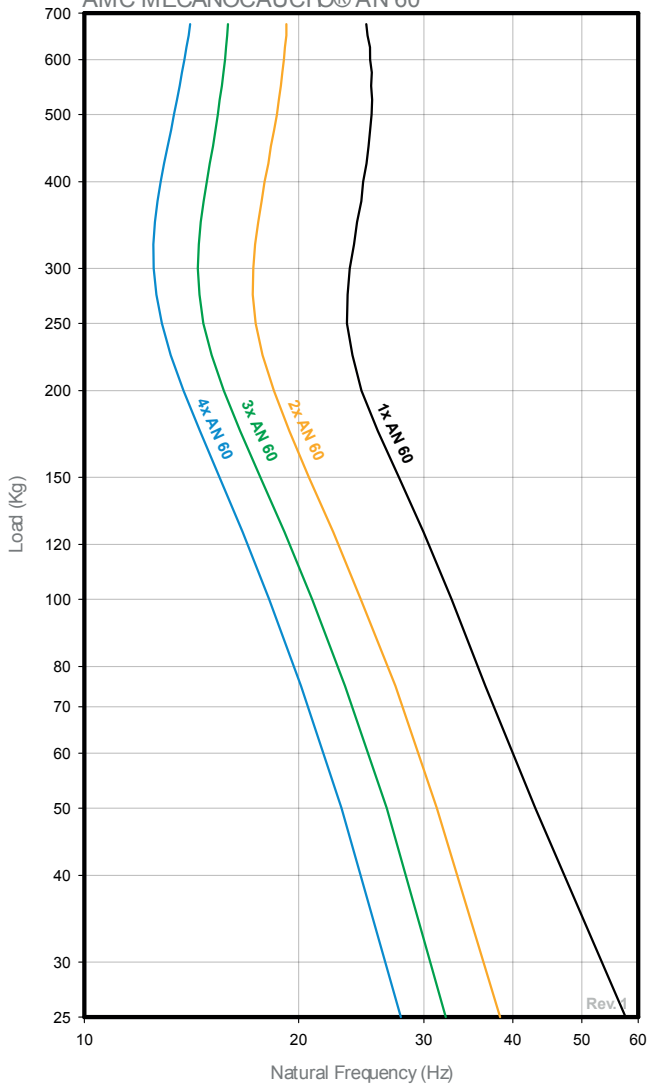

LOAD DEFLECTION GRAPH
AMC MECANOCAUCHD® AN 60

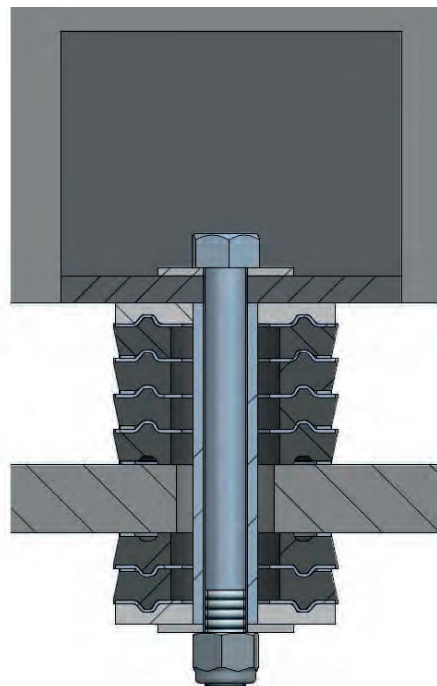
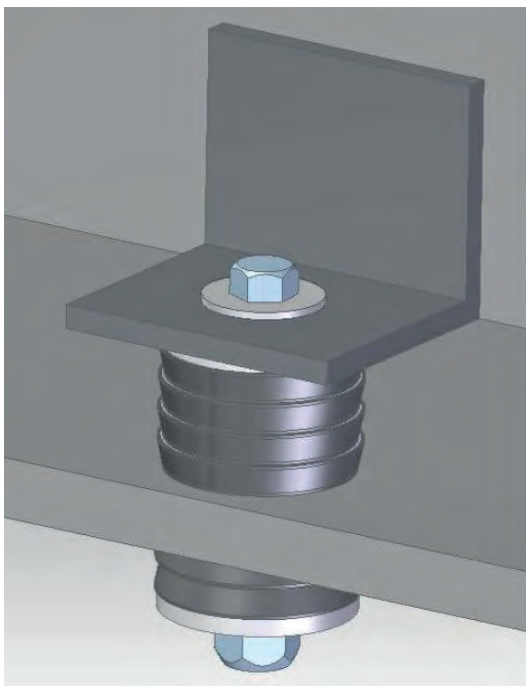
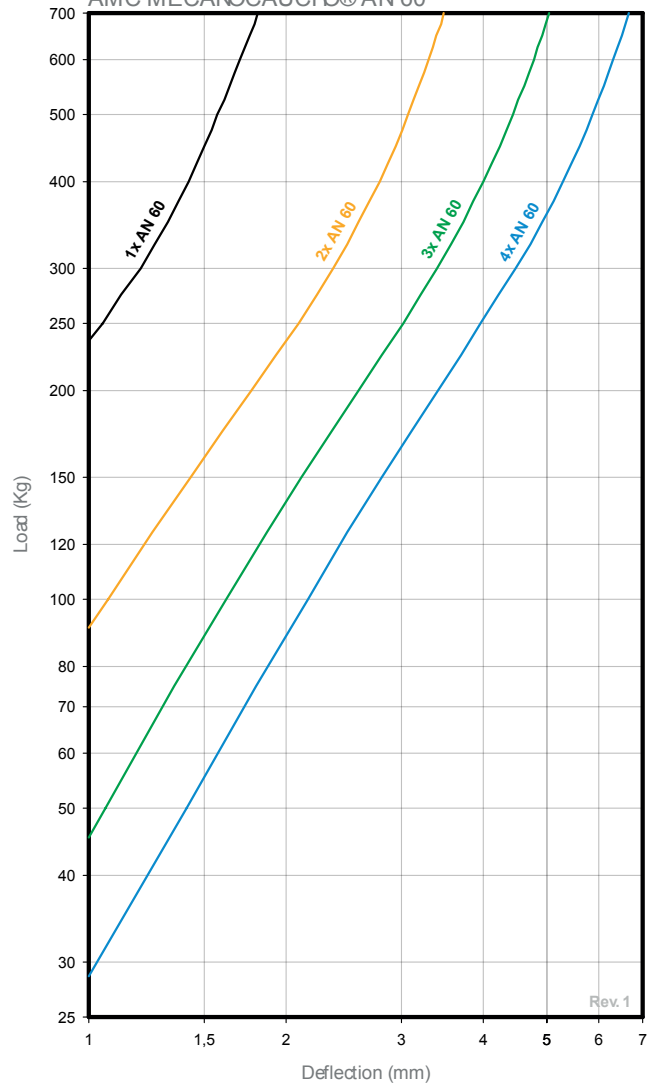

NP



DESCRIPTION

The AMC MECANOCAUCHO® NP mounts are composed of a metallic flange and a bush that are bonded to a high resilient rubber compound.

The AMC MECANOCAUCHO® NP mounts can be fitted with overload/rebound washers. This allows fail-safe installations. For this purpose we recommend using washer Ref. AMC: 608074 that has the following dimensions: 76 x 16.5 x 5mm.

The flange comes with four fixing holes and the inner bush allows up to 120 N/mm tightening torque.

TECHNICAL CHARACTERISTICS

AMC MECANOCAUCHO® NP mounts can be applied in mobile applications when installed with overload/rebound washers.

AMC MECANOCAUCHO® NP mounts are available in several rubber hardnesses to suit the load range of the application.

APPLICATIONS

AMC MECANOCAUCHO® NP mounts are used for the effective noise and vibration isolation in the following applications:

- Agricultural equipment
- Construction equipment machinery.
- Cranes.
- Forklift trucks.
- Multipurpose vehicles.

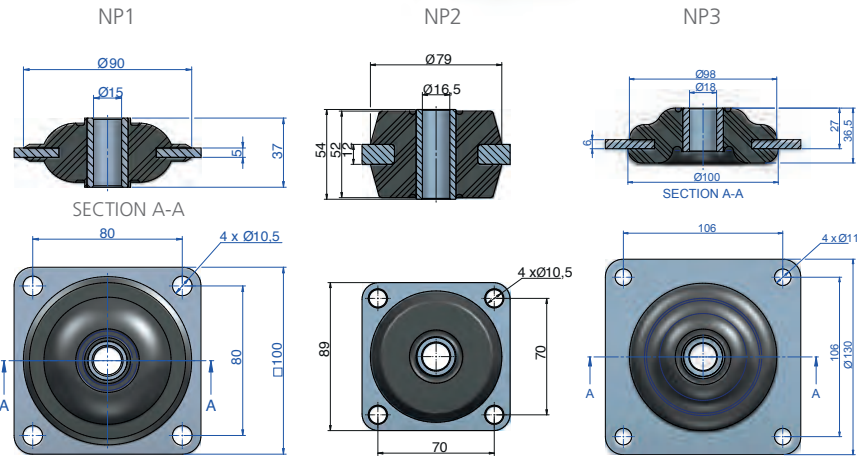

Type	Shore	Max. Load (kg)	Code	Type	Code
NP1	50Sh	250	138202	NP1 WASHER	608074
	60Sh	325	138201		
	70Sh	400	138203		
NP2	45Sh	320	138205	NP2 WASHER	608074
	60Sh	550	138206		
	70Sh	750	138207		
NP3	45Sh	110	138190	NP3 WASHER	610285
	60Sh	200	138191		
	70Sh	300	138192		

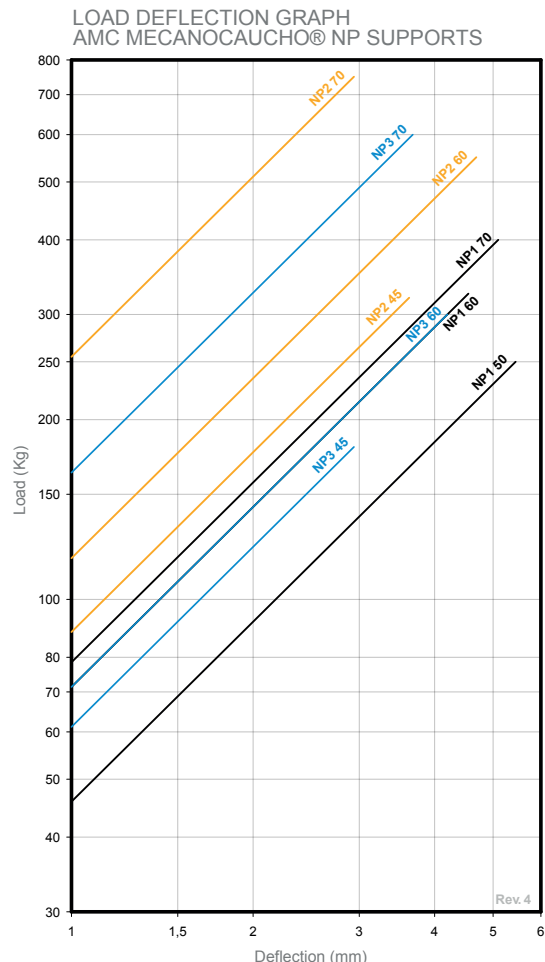
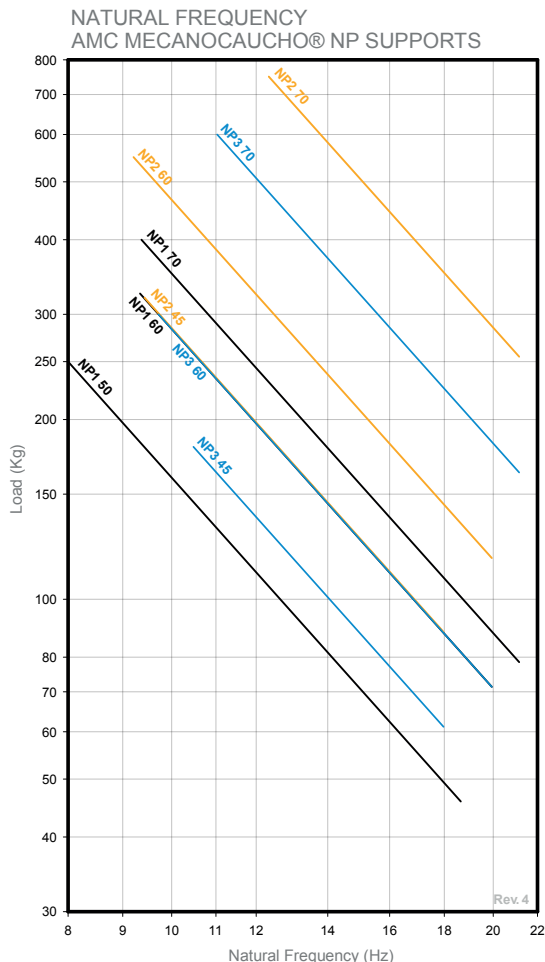

SN ANTI VIBRATION MOUNTS



APPLICATIONS

It is a support used in multiple applications, but primarily in marine engines whose excitation frequency is less than or close to 1000 rev/min.

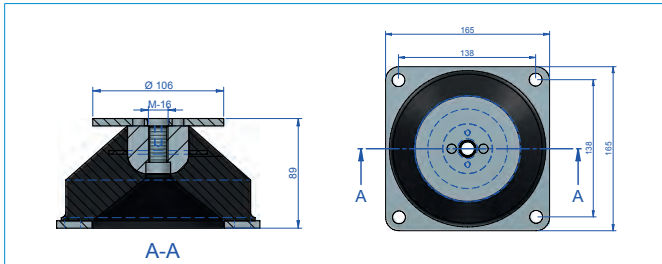

Type	Deflection mm	Weight (kg)	Shore	Max. Load (kg)	Code
SN	9	2,61	45 Sh	180	139001
	8	2,61	60 Sh	240	139002

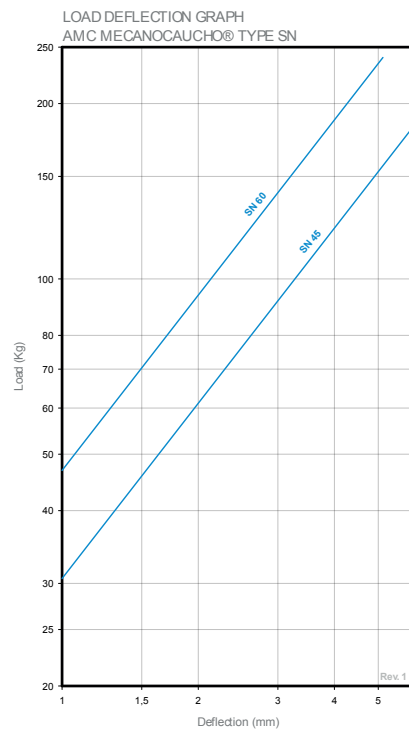
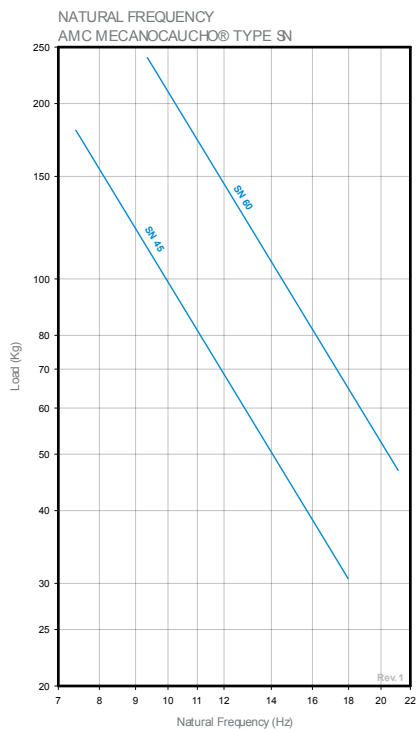

MECANOCAUCHO® TFS

The AMC-Mecanocaucho® TFS type anti vibration mounts are made of two symmetric moulded parts. They are designed to work in traction or compression providing a similar stiffness. When installed with metal washers they allow failsafe installations.

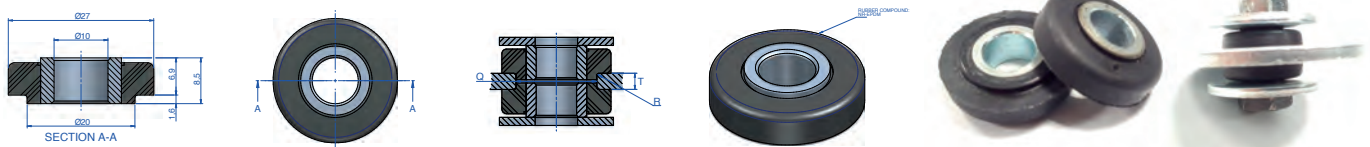

Type	Color Code	Shore	Q (mm)	T (mm)	Max. Load (kg)	R (mm)	Code
TFS 25	Yellow	45 Sh	20	4	10	1	138035

WASHERS

Washers are supplied on request.

Type	Weight (gr)	Øext (mm)	Øint (mm)	Thickness (mm)	Code
TFS 25	10	28,2	10,5	2	606185

* AMC S.A. reserves the right to modify the design and manufacture of the materials presented in this catalogue without prior notice.



DESCRIPTION

AMC MECANOCAUCHO® AT mounts are specifically designed to provide isolation for medium to high frequency applications.

The rubber section is fully bonded to two concentric tubular parts. The inner metal is a plain tube design. The outer metal part is also mainly tubular but has a manufacturing process Flanged effect at one end with a variation in the number of attachment holes.

TECHNICAL CHARACTERISTICS

Type AT mounts have a radial to axial ratio of 4:1 , thus providing good horizontal stability.

It is manufactured in three hardnesses to facilitate the choice of the most suitable mount (Soft: hardness A 45, Medium sized: hardness B 60 and Hard: hardness C 75).

APPLICATIONS

The AT elastic mounts can be used to great advantage for the vibration isolation of engines, piston compressors, presses, electric transformers, mobile units, machines, on concrete buttresses, etc.

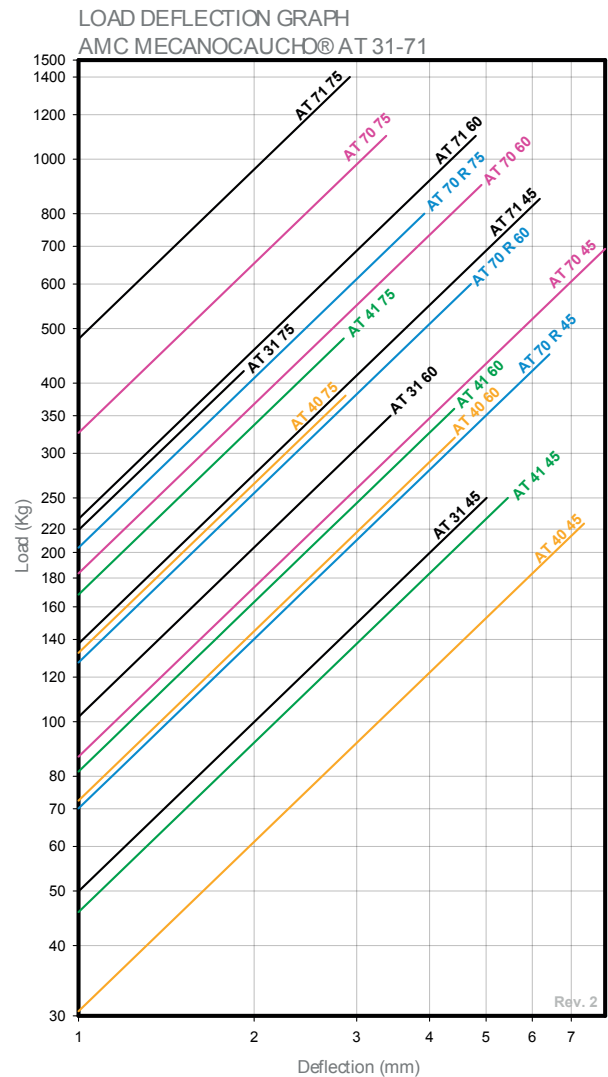
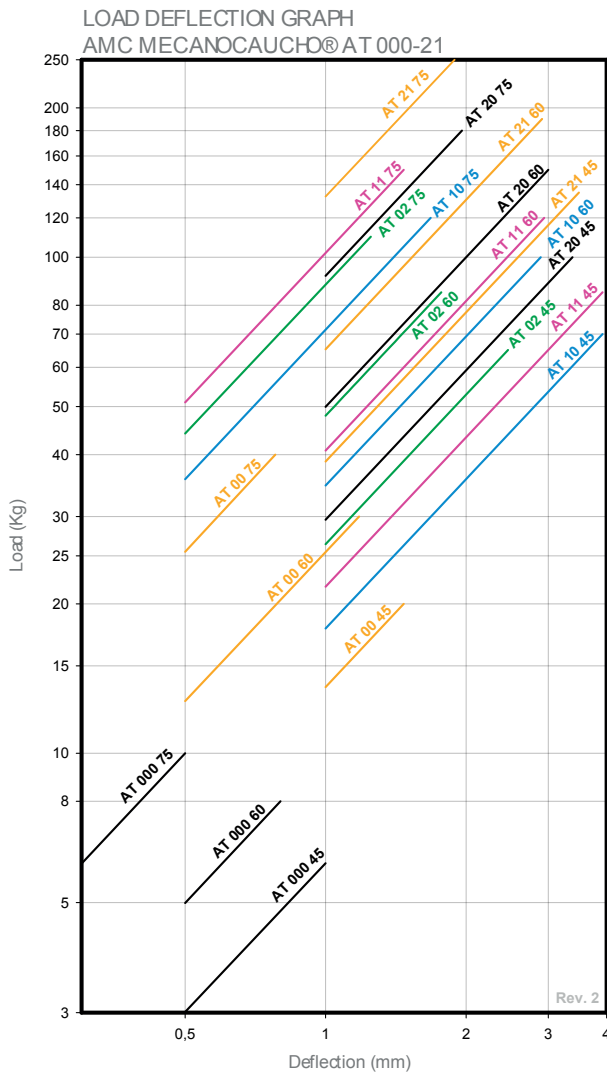

Fig. 1

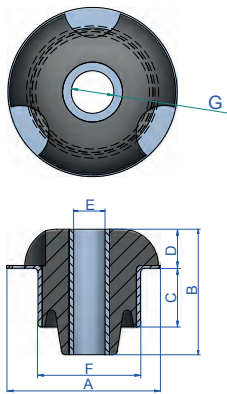

Fig. 2

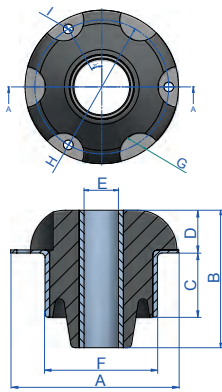

Fig. 3

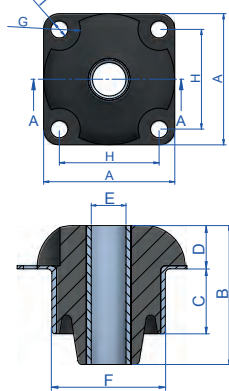
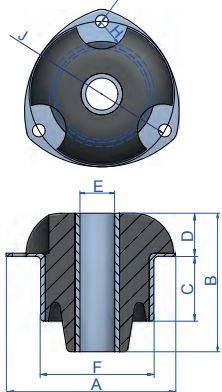

Fig. 4



Type	A (mm)	B (mm)	C (mm)	D (mm)	E (mm)	F (mm)	G (mm)	H (mm)	I (mm)	J (mm)	Weight (gr.)	Fig.	Code	Load (kg)	Shore
AT 000	25	11	3	6,5	6,4	20	4	19	3,2		8	3	132171	6	45 Sh
													132172	8	60 Sh
													132173	10	75 Sh
AT 00	36	28	12,5	11,5	8,2	26	12	26	5,2		39	3	132101	20	45 Sh
													132102	30	60 Sh
													132103	40	75 Sh
AT 02	48	51	24	18	12,1	37,6	8	-	-		144	1	132104	65	45 Sh
													132105	85	60 Sh
													132106	110	75 Sh
AT 10	60	47	18	19	12,2	49	11	69	8,2	73	250	4	132175	70	45 Sh
													132176	100	60 Sh
													132177	120	75 Sh
AT 11	60	60	30,5	19	12,2	49	11	69	8,2	73	250	4	132107	85	45 Sh
													132108	120	60 Sh
													132109	150	75 Sh
AT 20	71	55	27,5	19	18,3	55,7	10	-	-		344	1	132110	100	45 Sh
													132111	150	60 Sh
													132112	180	75 Sh
AT 21 round	70	70	38,5	20,7	18,3	55,7	10	80	8,5	86	437	1	132113	135	45 Sh
													132114	190	60 Sh
													132115	250	75 Sh
AT 21 lugs	70	70	38,5	20,7	18,3	55,7	10	80	8,5	86	437	4	132116	135	45 Sh
													132117	190	60 Sh
													132118	250	75 Sh
AT 31 lugs	90	95	47	28	20,2	65	16	95	8,5	107	780	4	132136	250	45 Sh
													132137	350	60 Sh
													132138	420	75 Sh
AT 40 round	100	90	42	28	22,2	74	18	100	8,5	112	789	1	132139	225	45 Sh
													132140	320	60 Sh
													132141	380	75 Sh
AT 40 lugs	100	90	42	28	22,2	74	18	100	8,5	112	780	4	132142	225	45 Sh
													132143	320	60 Sh
													132144	380	75 Sh
AT 41 round	100	110	49	28	22,2	74	18	100	8,5	112	895	1	132145	250	45 Sh
													132146	360	60 Sh
													132147	480	75 Sh
AT 41 lugs	100	110	49	28	22,2	74	18	100	8,5	112	900	4	132148	250	45 Sh
													132149	360	60 Sh
													132161	480	75 Sh
AT 70 lower	163,5	97	36	46	60,2	118	22	145	10,5		3124	2	132162	450	45 Sh
													132163	600	60 Sh
													132164	800	75 Sh
AT 70	163,5	140	66	46	60,2	118	22	145	10,5		3124	2	132165	700	45 Sh
													132166	900	60 Sh
													132167	1100	75 Sh
AT 71	163,5	170	96	46	60,2	118	22	145	10,5		3790	2	132168	850	45 Sh
													132169	1100	60 Sh
													132170	1400	75 Sh





SPS

DESCRIPTION

AMC MECANOCAUCHO® SPS type mounts are comprised of two pressed metal parts. A cup shaped Top Cap and a pressed steel inverted cup shaped base, two moulded rubber sections are assembled to the metal parts and secured by means of a swaged centre insert which is threaded.

TECHNICAL CHARACTERISTICS

Due to the design, SPS mounts can work with compression and tensile loads, isolating effectively using the friction of the rubber section with the surfaces of the assembled metal parts. It is most effective in applications where high frequency vibrations are predominant.

Various rubber compounds are available for insertion depending upon the applications to be considered, high temperatures, oil and diesel resistance, and ageing resistance against Ozone attack.

APPLICATIONS

With a captive rubber unit the SPS mounts afford total safety in Mobile applications. They are compact in design for the range of loads to be supported and can be manufactured in Stainless Steel metal parts as an option for Food Industry applications, and coupled with appropriate compounds for the environments involved.

Applications range from high speed operation equipment such as Refrigeration units, Compressors, Transformers, HVAC units on trains or coaches.

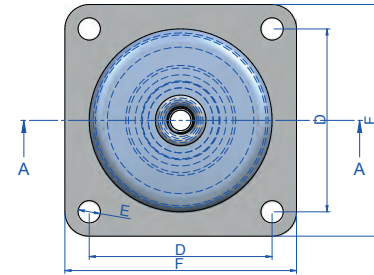
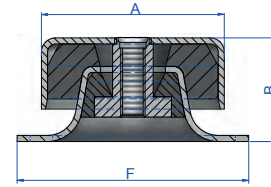

Type	A (mm)	B (mm)	C (mm)	D (mm)	E (mm)	F (mm)	G (mm)	Weight (gr.)	Code	Load (kg)	Shore
SPS 020	50	28	M-8	50	6	60	1,5	171	140001	80	45 Sh
									140003	100	60 Sh
									140005	150	75 Sh
SPS 120	76	39	M-10	63,5	6,7	76	3	524	140002	180	45 Sh
									140004	240	60 Sh
									140006	300	75 Sh
SPS 220	90	51	M-12	90	11	114	3	971	140007	170	45 Sh
									140008	300	60 Sh
									140009	450	75 Sh
SPS 420	125	78	M-16	114	13	144	4	2424	140034	800	55 Sh
									140035	1400	65 Sh
									140033	1625	75 Sh

NATURAL FREQUENCY
AMC MECANOCAUCHO® SPS

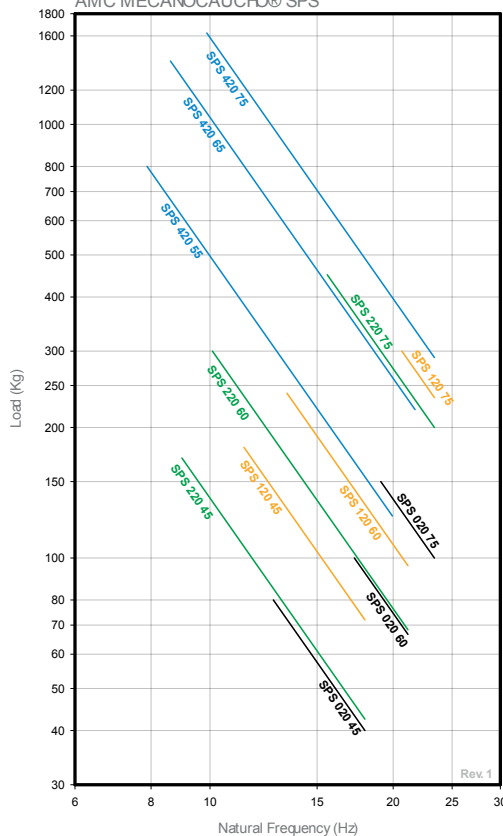

LOAD DEFLECTION GRAPH
AMC MECANOCAUCHO® SPS

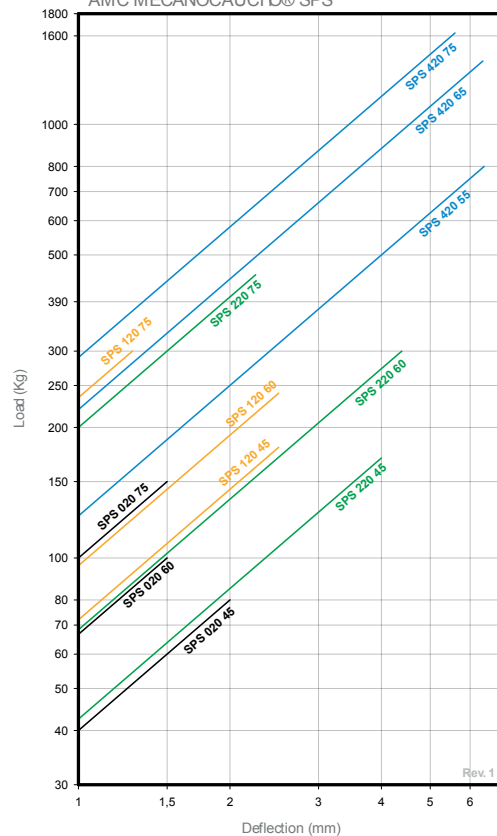

AKUSTIK PIPE / PIPE OMEGA+ SYLOMER®

AMC-MECANOCAUCHO® Akustik Pipes are specially suitable for applications where rigid or flexible pipes must be isolated, both for static and dynamic applications.

GO TO VIDEO



TYPE B

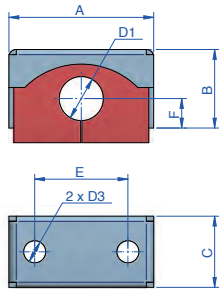

TYPE A

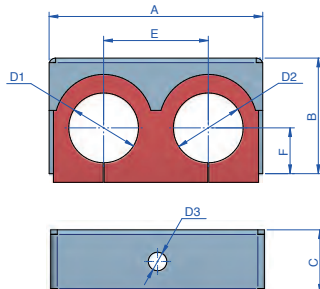

OMEGA

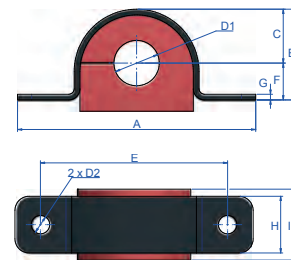

Type	A (mm)	B (mm)	C (mm)	D1 (Min.)	D2 (Max.)	E (mm)	F (mm)	D3 (Max.)	Code
Type A	70	34,5	29	15	18	36	15	8,5	23872
	70	34,5	29	18	18	36	15	8,5	23873
	82	42	29	21,2	24,3	43	15	8,5	23874
	70	34,5	29	22	22	36	13	8,5	23871
	98	51,5	29	28	28	48	21	8,5	23876
	98	51,5	29	32	32	48	21	8,5	23875
Type B	59	32	29	18	-	38	12	9	23877
Type Omega	84	32	19	10	6,5	66	13	-	23892
	84	32	19	14	6,5	66	13	-	23893
	94	42	24	20	6,5	76	18	-	23894
	94	42	24	26	6,5	76	18	-	23895
	69	24	13	5,5	6,5	51	11	-	23896
	84	32	19	16	6,5	66	13	-	23897
	104	50	28	33	6,5	86	22	-	23898

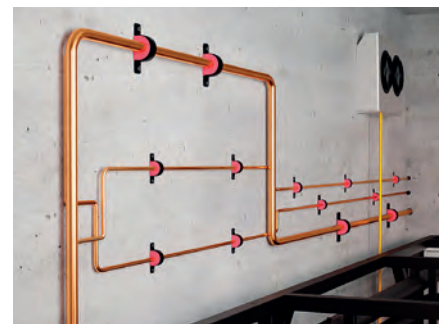

NATURAL FREQUENCY

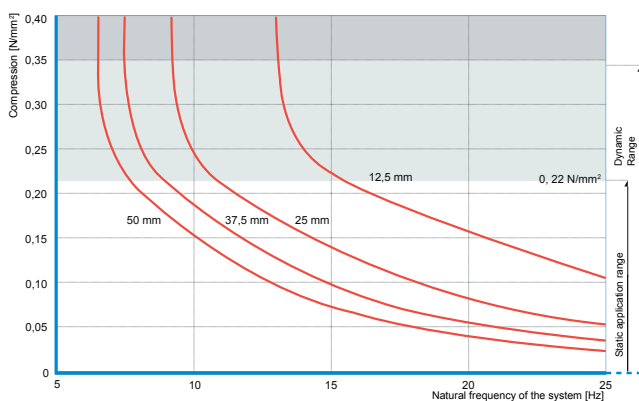

LOAD-DEFLECTION

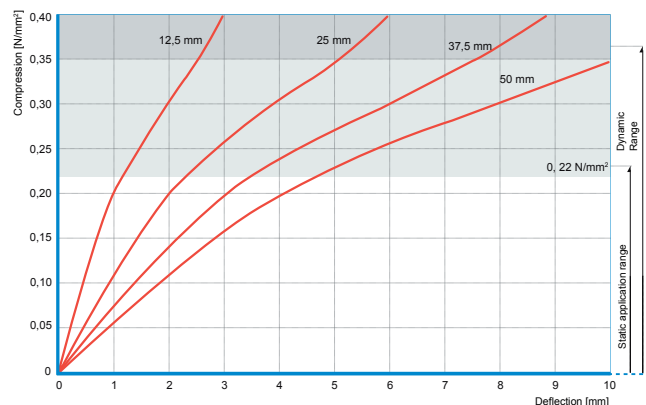

WF

DESCRIPTION

A range designed for the suspension of loudspeakers, electrical panels, air conditioning equipment, etc.

These mounts are also suitable for insulating standpipes, or any type of lightweight ductwork that requires insulation.

They have a robust metal structure that is «FAIL SAFE» overload proof.



GO TO VIDEO

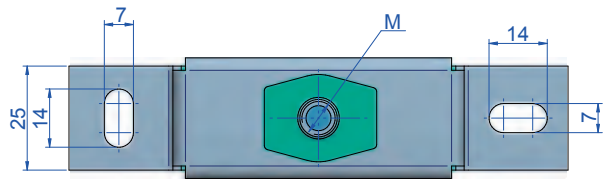
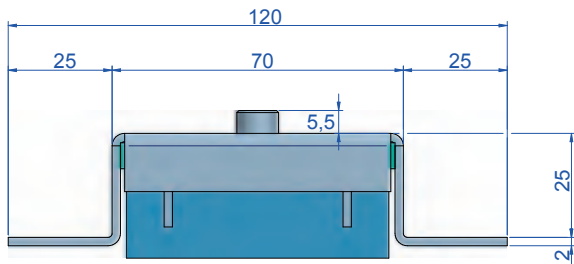
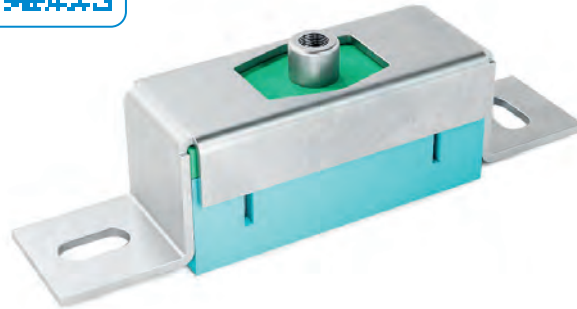

Type	Max. Load (kg)	M	Weight (gr)	Code
Akustik + Sylomer WF 5	2.5-5	M6	119	23805
		M8	119	23806
Akustik + Sylomer WF 10	5-10	M6	124	23807
		M8	124	23808
Akustik + Sylomer WF 15	10-15	M6	127	23809
		M8	127	23810

GO TO
CALCULATION TOOL



ONLINE CALCULATION

This calculation tool considers the use of 4 anti-vibration mounts.

It is important to make the installation so the following limits are not exceeded:

- **Max.** separation of the center of gravity from the wall (distance E of the schematic): 30cm
- **Min.** vertical separation between WF mounts (distance H of the schematic): 20cm

Load kg lbs

Frequency RPM Hz

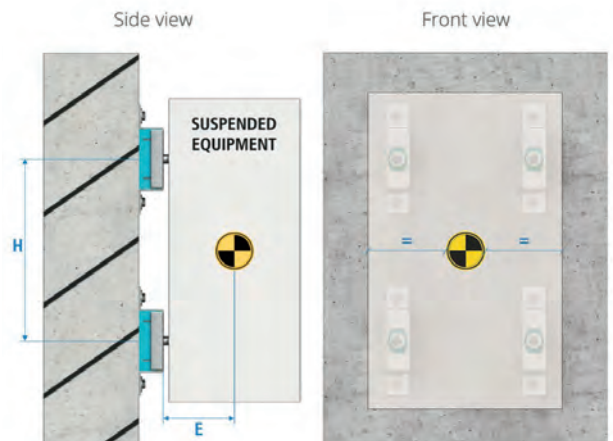

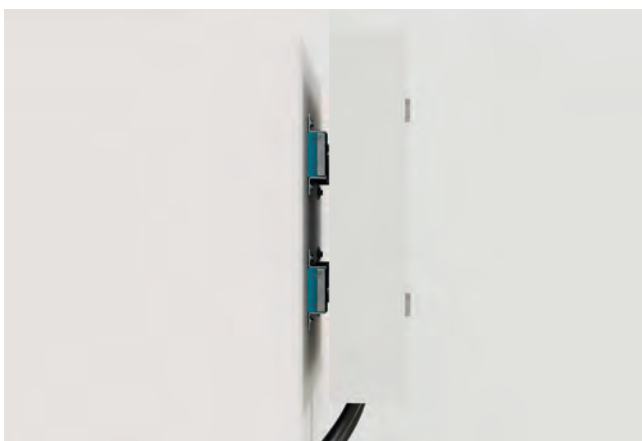
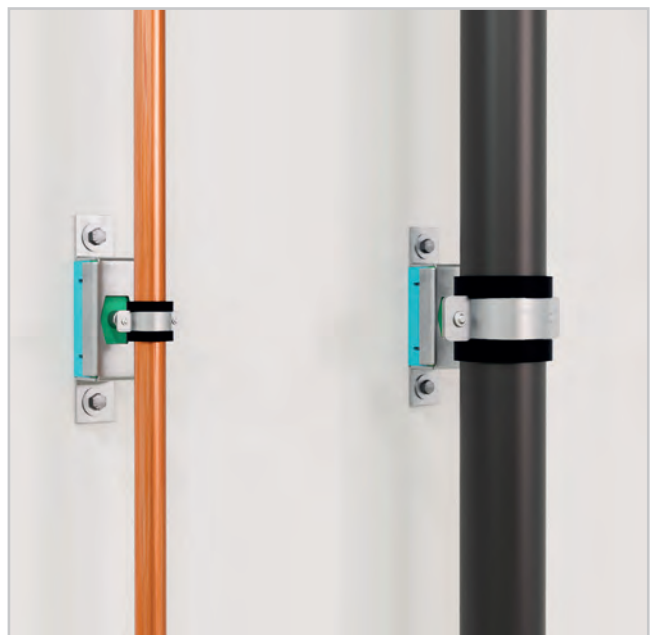
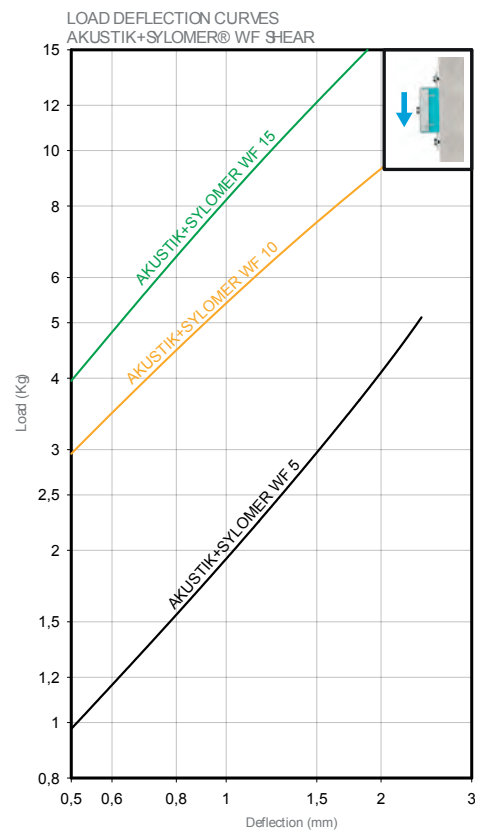
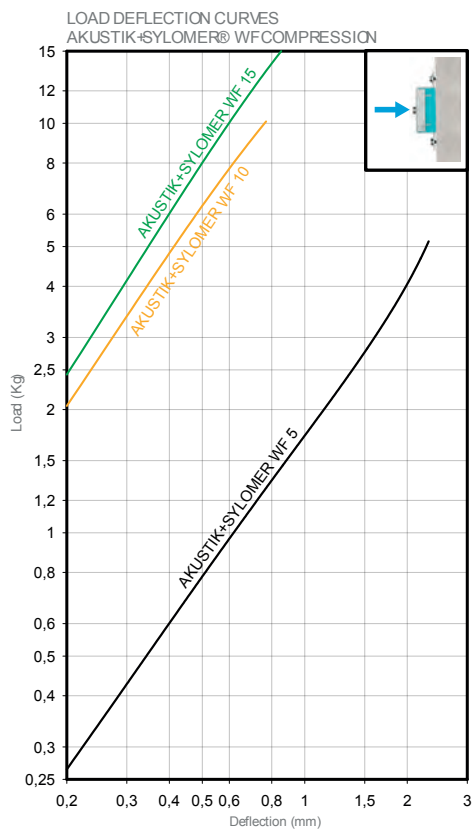

FZ + SYLOMER® MOUNTS



DESCRIPTION

The AMC MECANOCAUCHO® FZ mounts use high resiliency Sylomer® polyurethane compounds. The internal architecture of the mount is composed of two metal parts surrounded by the elastic compound. The exterior metallic armor incorporates 4 holes for the fixation of the mount to the frame. The interior metal part consists of a machined metal ring that transfers the traction and compression loads to the elastomer. This machined metal ring has a wider diameter than the exterior metal armor acting as a failsafe device.

TECHNICAL CHARACTERISTICS

- The AMC-MECANOCAUCHO FZ mounts incorporate an interlocking metal component that provide a fail-safe protection for mobile applications. This device limits the ascending vertical movement when the mounting is submitted to shocks at traction.
- The thickness of the metal parts are robust and are suitable for off-road applications. The metal parts have a suitable anticorrosive treatment for outdoor applications.
- The Sylomer® polyurethane compound is oil resistant and the temperature range of the FZ mounts is -30°C to +70°C.

APPLICATIONS

The AMC MECANOCAUCHO® FZ mounts have been primarily designed for static applications.

They are often used for the isolation of sensitive equipment embarqued on vehicles submitted to shocks.

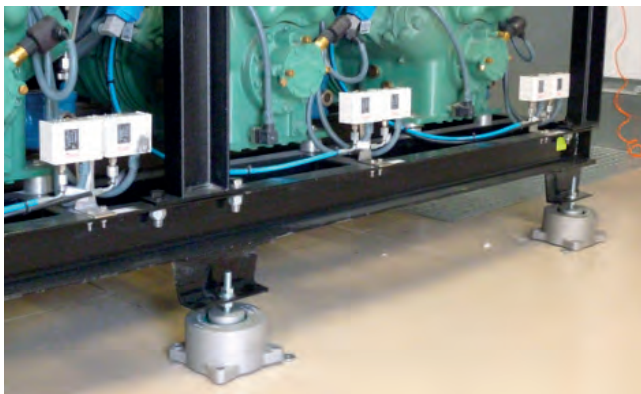

Example of installation on a HVAC equipment

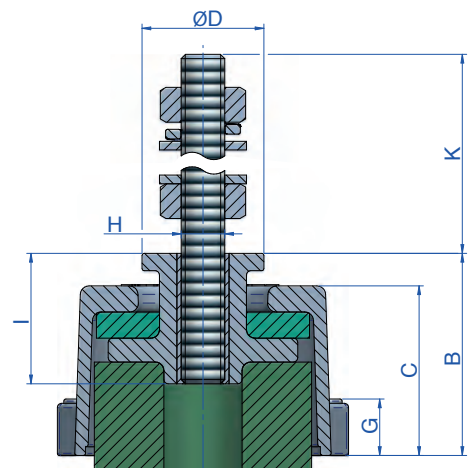
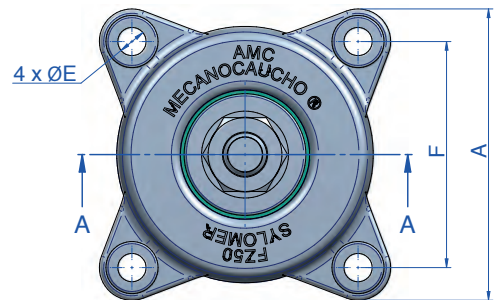

A-A SECTION

Type	A (mm)	B (mm)	C (mm)	D (mm)	E (mm)	F (mm)	G (mm)	H (mm)	I (mm)	K (mm)	Load (kg)	Weight (gr.)	Code
FZ-50-27-M10 + LEV KIT	67	46.5	39	28	6.5	52	13	10	26	60	15	311	176293
FZ-50-33-M10 + LEV KIT	67	46.5	39	28	6.5	52	13	10	26	60	25	311	176295
FZ-50-39-M10 + LEV KIT	67	46.5	39	28	6.5	52	13	10	26	60	45	311	176297
FZ-50-45-M10 + LEV KIT	67	46.5	39	28	6.5	52	13	10	26	60	50	311	176281
FZ-50-51-M10 + LEV KIT	67	46.5	39	28	6.5	52	13	10	26	60	50-100	311	176291
FZ-100-45-M12 + LEV KIT	82	56	48	25	6.5	67	13	12	27,5	60	100-150	464	176299
FZ-100-51-M12 + LEV KIT	82	56	48	25	6.5	67	13	12	27,5	60	150-200	464	176301
FZ-200-51-M12 + LEV KIT	109	72	55	40	8,5	90	15	12	27,5	60	170-280	978	176311
FZ-200-57-M12 + LEV KIT	109	72	55	40	8,5	90	15	12	27,5	60	280-400	978	176321
FZ-200-57-M14 + LEV KIT	109	72	55	40	8,5	90	15	14	27,5	60	280-400	978	176323
FZ-400-51-M14 + LEV KIT	155	94	80	65	12,5	125	22	14	27,5	60	460-800	2461	176331
FZ-400-57-M16 + LEV KIT	155	94	80	65	12,5	125	22	16	27,5	60	800-1000	2461	176341
FZ-600-51-M18 + LEV KIT	175	94	80	65	14	140	23	18	28	60	1000-1200	3077	176351
FZ-600-57-M20 + LEV KIT	175	94	80	65	14	140	23	20	28	60	1200-1500	3077	176361
FZ-1000-57-M20 + LEV KIT	205	95	80	65	16	162	28	20	28	60	1500-2000	3751	176371
FZ-50-27-M10	67	46.5	39	28	6.5	52	13	10	26	-	15	260	176294
FZ-50-33-M10	67	46.5	39	28	6.5	52	13	10	26	-	25	260	176296
FZ-50-39-M10	67	46.5	39	28	6.5	52	13	10	26	-	45	260	176298
FZ-50-45-M10	67	46.5	39	28	6.5	52	13	10	26	-	50	260	176282
FZ-50-51-M10	67	46.5	39	28	6.5	52	13	10	26	-	50-100	260	176292
FZ-100-45-M12	82	56	48	25	6.5	67	13	12	27,5	-	100-150	380	176300
FZ-100-51-M12	82	56	48	25	6.5	67	13	12	27,5	-	150-200	380	176302
FZ-200-51-M12	109	72	55	40	8,5	90	15	12	27,5	-	170-280	868	176312
FZ-200-57-M12	109	72	55	40	8,5	90	15	12	27,5	-	280-400	868	176322
FZ-200-57-M14	109	72	55	40	8,5	90	15	14	27,5	-	280-400	868	176324
FZ-400-51-M14	155	94	80	65	12,5	125	22	14	27,5	-	460-800	2253	176332
FZ-400-57-M16	155	94	80	65	12,5	125	22	16	27,5	-	800-1000	2253	176342
FZ-600-51-M18	175	94	80	65	14	140	23	18	28	-	1000-1200	2756	176352
FZ-600-57-M20	175	94	80	65	14	140	23	20	28	-	1200-1500	2756	176362
FZ-1000-57-M20	205	95	80	65	16	162	28	20	28	-	1500-2000	3348	176372

NATURAL FREQUENCY
AMC MECANOCAUCHO® FZ + Sylomer®

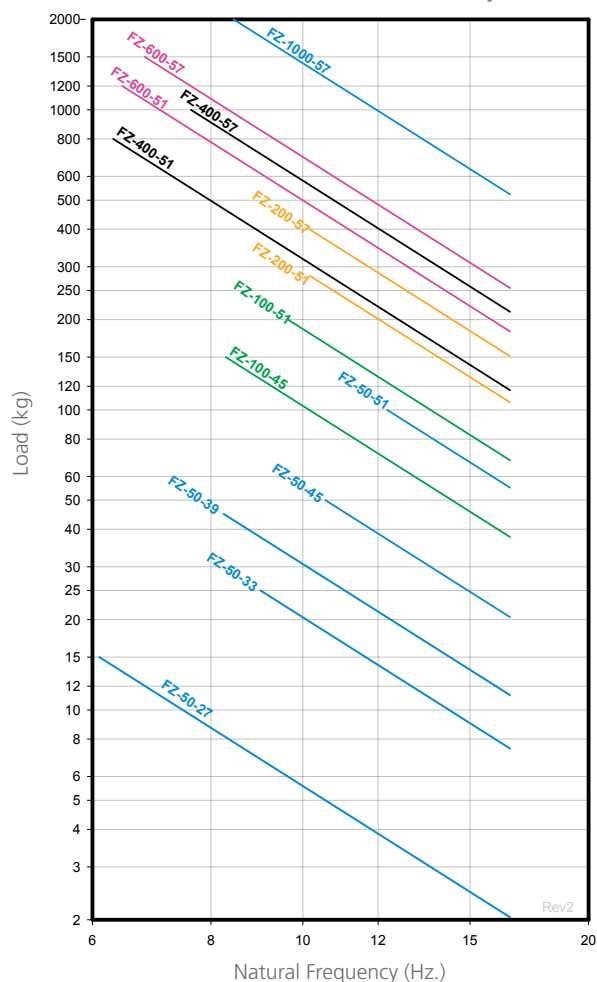

LOAD DEFLECTION GRAPH
AMC MECANOCAUCHO® FZ + Sylomer®

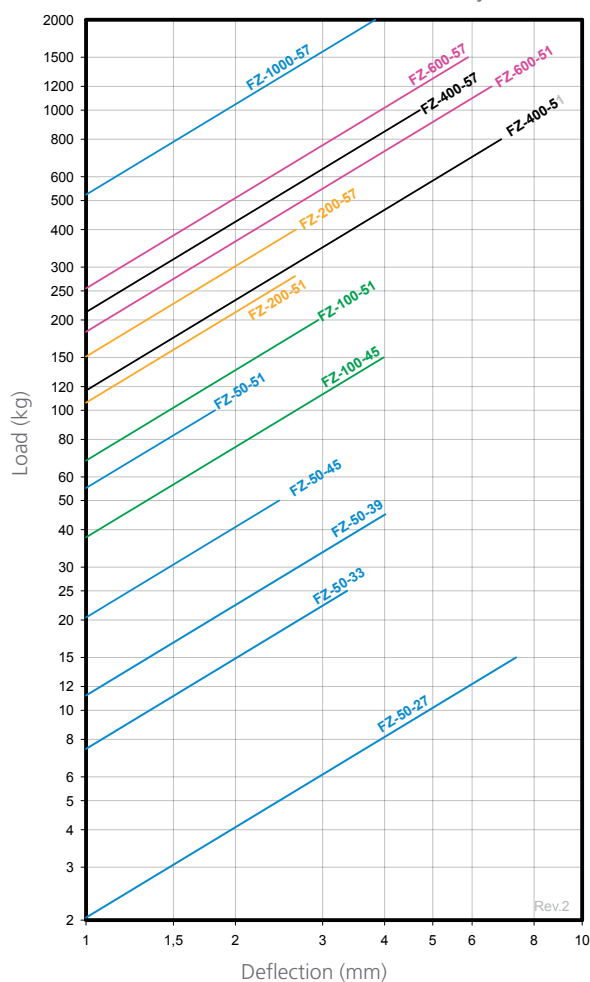



SFC MARINE EXHAUST MOUNTS

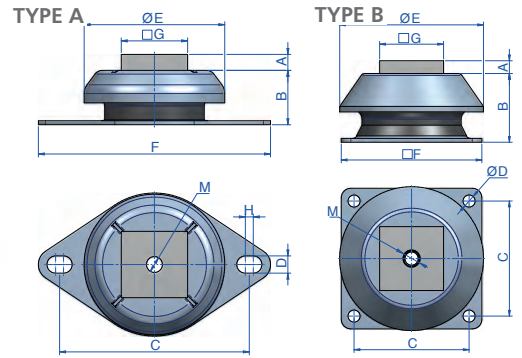

Type	A (mm)	B (mm)	C (mm)	D (mm)	E (mm)	F (mm)	G (mm)	H (mm)	M	Shore	Max. Load (kg)	Code
Type A	12	34	123,2	10	92	150	50	4,4	M12	60 Sh	270	709301
	12	41	143	13	106	175	50	6	M12	60 Sh	420	709305
	12	53,5	182	14,5	156	218	90	6	M16	60 Sh	800	709311
Type B	12	105	180	19	230	220	90	-	M24	60 Sh	3400	709315

SFT MARINE EXHAUST MOUNTS

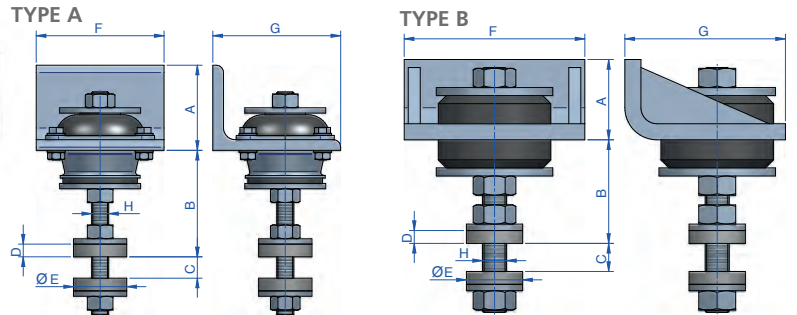
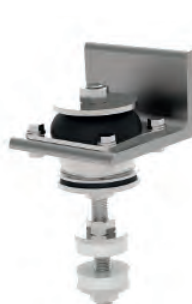

Type	A (mm)	B (mm)	C (mm)	D (mm)	E (mm)	F (mm)	G (mm)	H (mm)	Shore	Max. Load (kg)	Code
Type A	50	51,5	20	12	50	110	100	M12	45 Sh	75	709201
	50	51,5	20	12	50	110	100	M12	60 Sh	140	709205
	50	51,5	20	12	50	110	100	M12	45 Sh	100	709211
	50	51,5	20	12	50	110	100	M12	60 Sh	180	709215
	80	80	40	12	50	120	120	M16	40 Sh	140	709221
	80	80	40	12	50	120	120	M16	60 Sh	300	709225
	80	80	40	12	50	120	120	M16	60 Sh	500	709231
	80	80	40	12	50	120	120	M16	70 Sh	750	709235
	100	100	50	12	50	175	150	M20	45 Sh	900	709241
	100	100	50	12	50	175	150	M20	60 Sh	1250	709245
Type B	100	120	50	12	70	225	200	M30	60 Sh	2000	709251

ST MARINE EXHAUST MOUNTS

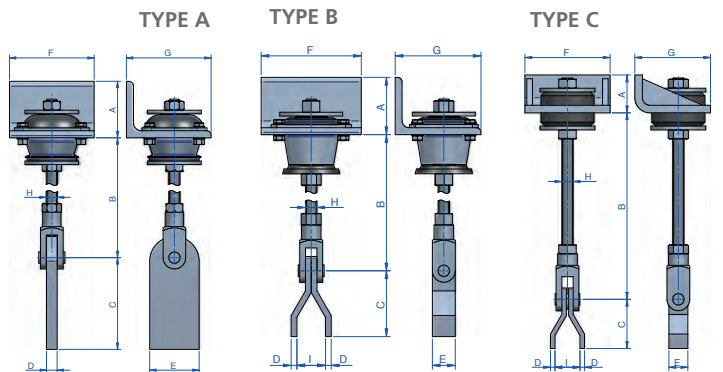

Type	A (mm)	B (mm)	C (mm)	D (mm)	E (mm)	F (mm)	G (mm)	H (mm)	I (mm)	Shore	Max. Load (kg)	Code
Type A	50	325	118	10	50	110	100	M12	-	45 Sh	75	709101
	50	325	118	10	50	110	100	M12	-	60 Sh	140	709105
	50	325	118	10	50	110	100	M12	-	45 Sh	100	709111
	50	325	118	10	50	110	100	M12	-	60 Sh	180	709115
	80	477	130	15	70	120	120	M16	-	40 Sh	140	709121
	80	477	130	15	70	120	120	M16	-	60 Sh	300	709125
	80	477	130	15	70	120	120	M16	-	60 Sh	500	709131
	80	477	130	15	70	120	120	M16	-	70 Sh	750	709135
Type B	100	485	115	10	40	175	150	M20	50	65 Sh	1100	709141
Type B	100	485	115	10	40	175	150	M20	50	75 Sh	1570	709145
Type C	100	500	130	12	50	225	200	M30	66	60 Sh	2000	709151

WIRE ROPE ANTI VIBRATION MOUNT



DESCRIPTION

AMC-MECANOCAUCHO® Wire Rope Mounts consist in two aluminium discs linked by several toric winding made out of a stainless steel cable.

The assembly of this mounting is very simple due to its compact and symmetric design, providing a constant radial stiffness in all directions. This feature makes unnecessary the radial alignment of the mount.

APPLICATIONS

AMC-MECANOCAUCHO® Wire Rope Mounts, due to their low stiffness, are specially suitable for applications where small static loads are involved and high isolation level is required.

Moreover, these mounts assure the stability of the suspended equipment by limiting the deflection that can be achieved, both in compression and tension, as well as in radial direction. These features make Wire Rope Mounts suitable to be subject to shock inputs. The materials in which these mounts are made protect the Wire Rope Mounts against aging and corrosion.

TYPE A 30

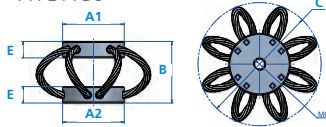

TYPE A 48

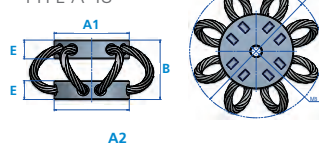

TYPE B

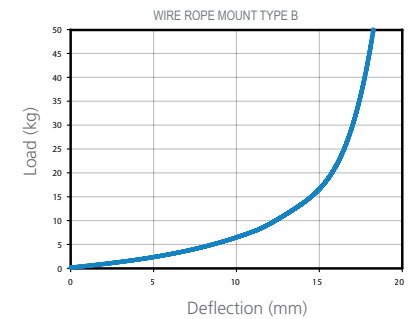
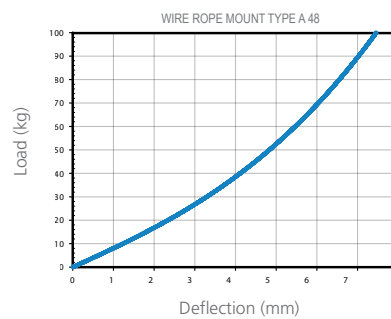
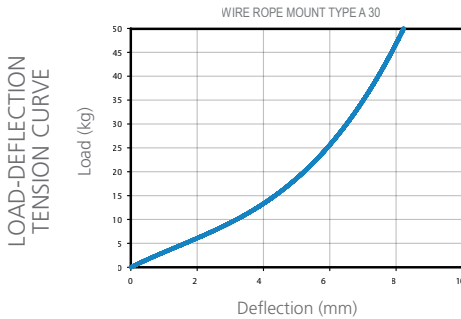
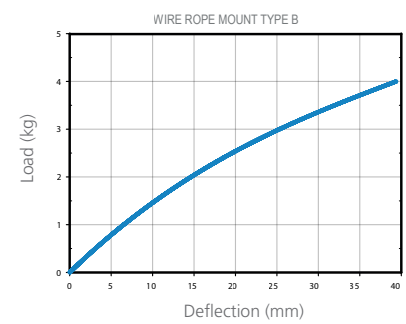
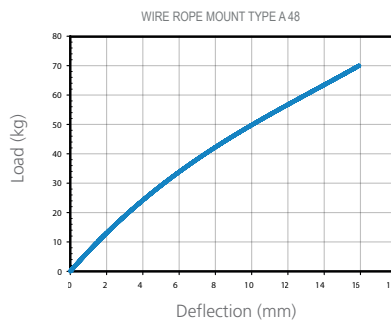
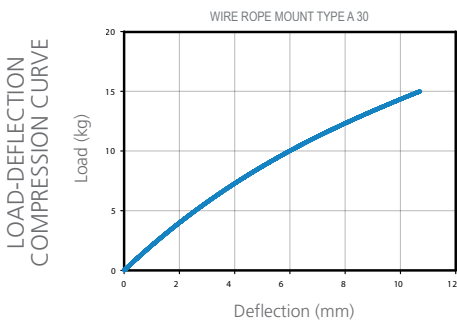
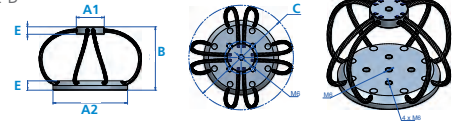

Type	Maximum static load (Kg)	Maximum Total Load (N)	Code
TYPE A 30	6	150	171200
TYPE A 48X38	28	700	171202
TYPE A 48X50	18	350	171203
TYPE B	2	40	171201

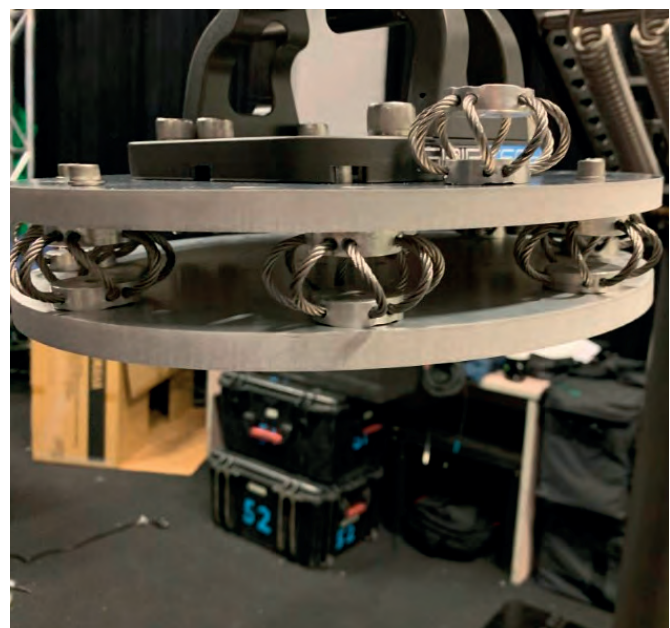

HELICAL WIRE ROPE SOLUTIONS

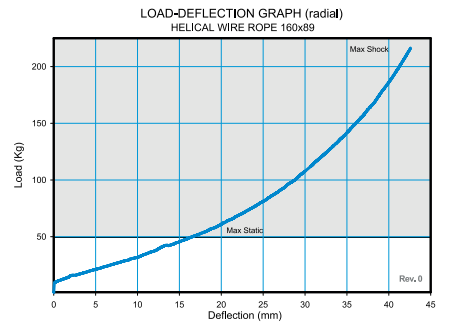
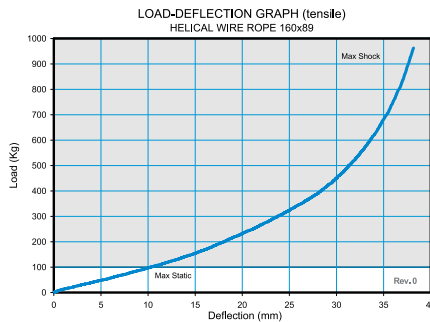
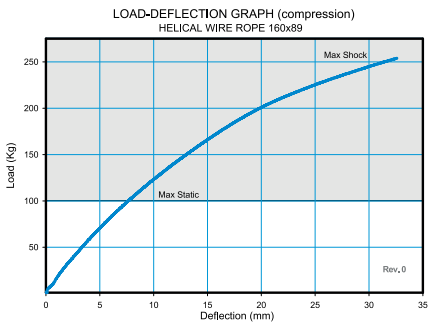
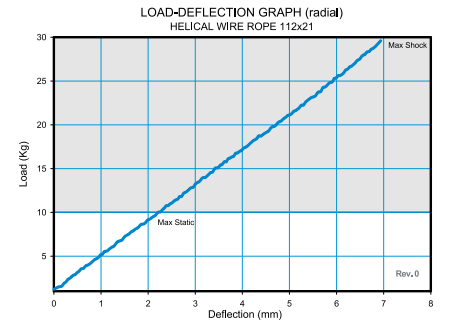
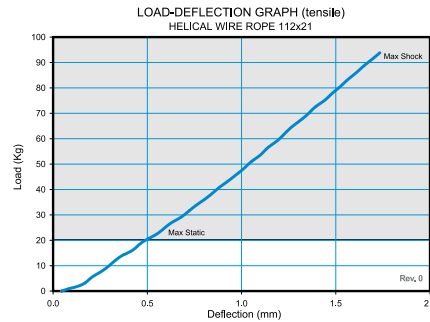
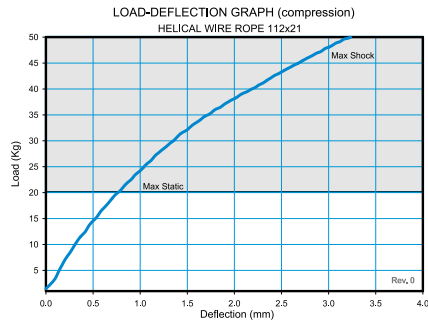
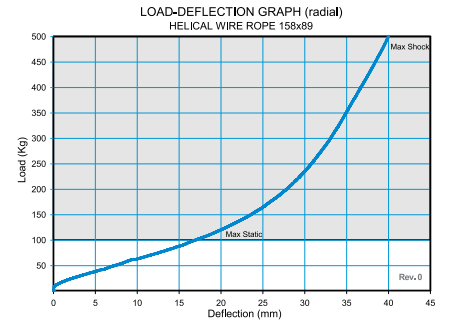
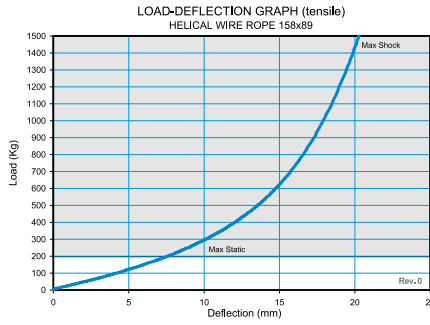
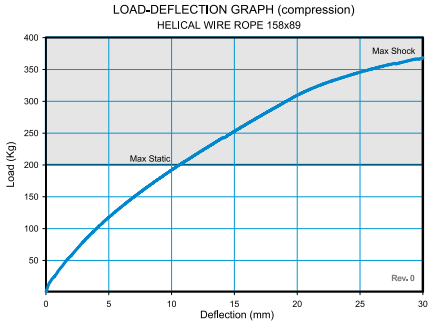

TYPE 112x21

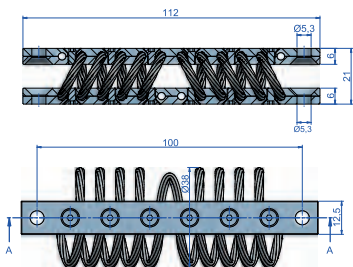

TYPE 158x89

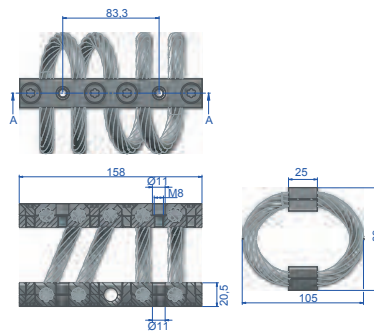

TYPE 160x89

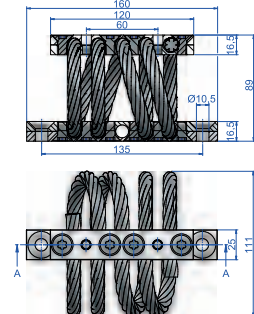

Type	Maximum static load (Kg)	Maximum Total Load (N)	Weight (kg)	Code
Type 112x21	20	50	0,14	171209
Type 158x89	200	375	1,76	171210
Type 160x89	100	260	1,011	171211

FZM



DESCRIPTION

The AMC-MECANOCAUCHO® type FZM mounts are ideal for mobile applications where high temperatures upto 300° C are present.

Its specific design allows very similar traction and compression stiffness rates. This feature is particularly useful on those applications where vibration in the vertical sense is predominant. The metal parts are robust and incorporate a fail-safe device in order to resist traction forces.

TECHNICAL CHARACTERISTICS

The cast aluminum bell has been designed to withstand to great dynamic shocks while the stainless steel wire fits tight to avoid relative displacements.

The stainless steel wire mesh and the aluminum top cap provide a higher resistance to marine corrosive environments, improving the performance of traditional marine antivibration mounts. The fail-safe device limits the vertical ascendant movement. The damping properties of the stainless steel wire mesh allows low amplification to resonance allowing stable suspended elements.

APPLICATIONS

The AMC-MECANOCAUCHO® type FZM metallic mount is used for applications exposed to high temperatures or mobile applications , for example mounting on board equipment in ships, rail, road transport such as engines, pumps, generator sets or pipe work or exhaust.

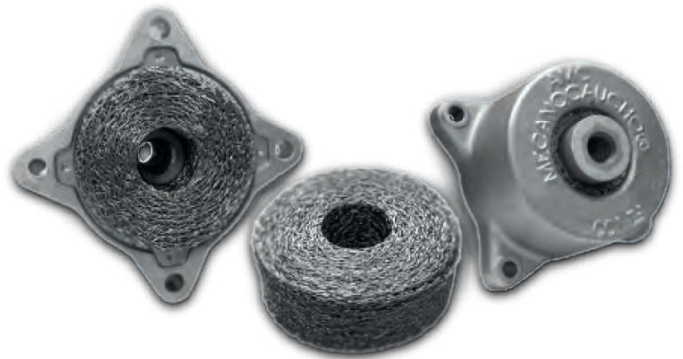

LOAD DEFLECTION GRAPH
AMC MECANOCAUCHO® FZM

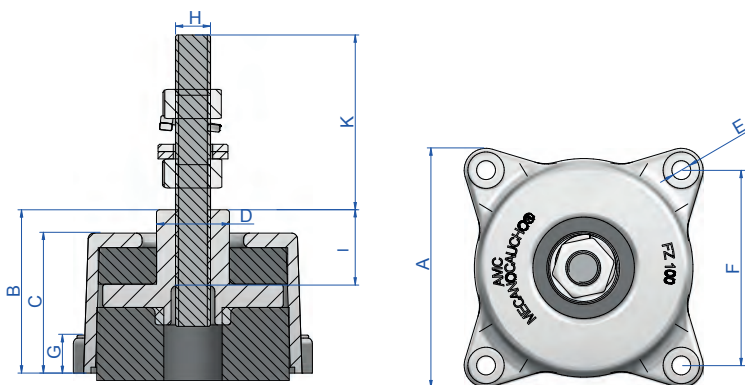
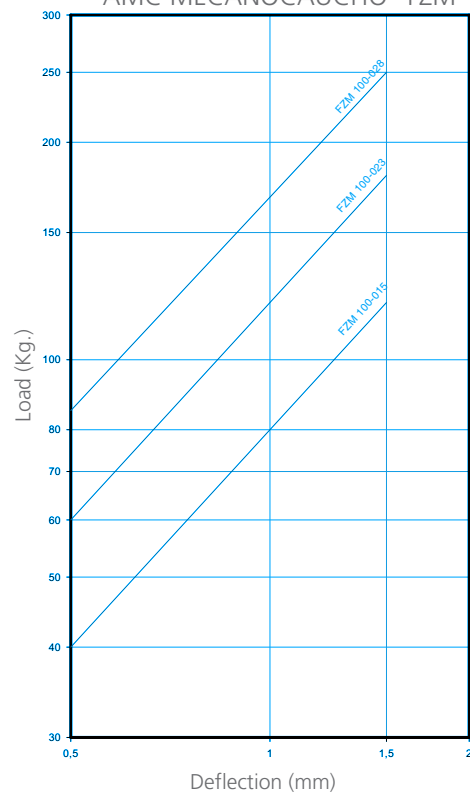

Type	A (mm)	B (mm)	C (mm)	D (mm)	E (mm)	F (mm)	G (mm)	H (mm)	I (mm)	K (mm)	Load (kg)	Weight (gr.)	Code
FZM 100-015 + KIT M12	80	56	48	25	6.5	67	13	12	40	60	120	842	176622
FZM 100-023 + KIT M12	80	56	48	25	6.5	67	13	12	40	60	180	842	176628
FZM 100-028 + KIT M12	80	56	48	25	6.5	67	13	12	40	60	250	842	176634
FZM 100-015	80	56	48	25	6.5	67	13	12	40	-	120	761	176621
FZM 100-023	80	56	48	25	6.5	67	13	12	40	-	180	761	176627
FZM 100-028	80	56	48	25	6.5	67	13	12	40	-	250	761	176633

* AMC S.A. reserves the right to modify the design and manufacture of the materials presented in this catalogue without prior notice.

SVT



DESCRIPTION

SVT mounts are anti-vibration mounts with pre-stressed stainless steel mesh, designed for high-temperature applications. Their robust metal parts ensure resistance to tensile loads, and the design provides equal stiffness in tension and compression, ideal for vertical vibrations.

With PU-coated carbon steel housing and stainless steel wire mesh, they offer excellent corrosion resistance and damping, minimizing resonance amplification. These mounts are used in high-temperature or mobile applications, such as ships, rail, road transport, and equipment like engines, pumps, and exhaust systems.

TECHNICAL CHARACTERISTICS

SVT mounts are anti vibration mounts that use a pre-stressed stainless steel mesh as elastic element. They are ideal for applications in which high temperatures are present. Its specific design allows very similar tensile and compression stiffness rates. This feature is particularly useful on those applications where vibration in the vertical sense is predominant. The metal parts are robust and incorporate a fail-safe device in order to resist tensile loads.

The steel housing has been designed to withstand to great dynamic shocks while the stainless steel mesh fits tight to avoid relative displacements. The stainless steel wire mesh and the PU coated carbon steel housing provide a higher resistance to corrosive environments. Moreover, the damping properties of the stainless steel wire mesh allows low amplification on resonance, allowing stable suspended elements.

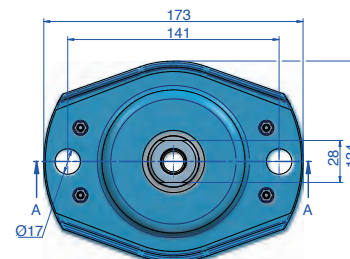
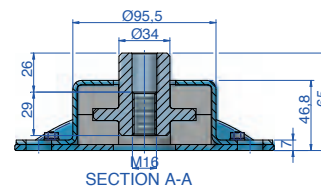
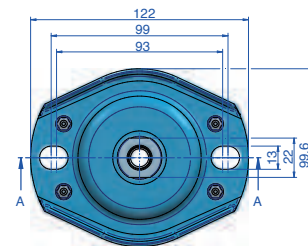
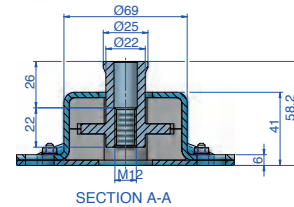

Type	Max.Load (kg)	Weight (gr)	Code
SVT-70	300	1581	176650
SVT-95	1400	2900	176670

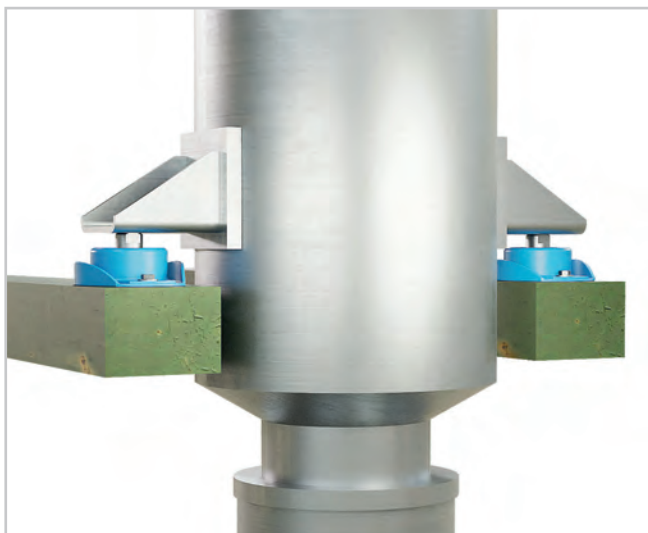

V-SHAPED GENERATOR MOUNT

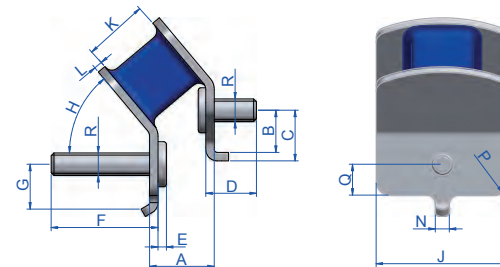
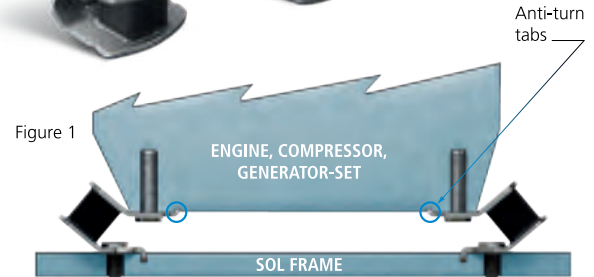

DESCRIPTION

The V-shaped AMC MECANOCAUCHO® Generator supports are comprised of two symmetrically-tilted metal parts with a screw on each side.

TECHNICAL CHARACTERISTICS

The V-shaped generator mounts render it possible to make installations which are more elastic than the ones usually made with cylindrical or bobbing mounts. This makes it possible to achieve lower frequencies and consequently better vibration isolation.

- Stability is enhanced when two are installed, symmetrically opposed. See fig. 1.
- They have two different length screws which facilitate the assembly of the the engine to the chassis. The screws can be supplied in different lengths to order.
- They have two "anti-turn" tabs which stop the mount from turning when strong tightening torque is applied (very frequently) with pneumatic tools.
- They are supplied in 2 hardnesses to adapt to different load ranges.
- They provide vibration attenuation of above 90% in diesel or petrol single-cylinder engines running at 3000 rpm.

APPLICATIONS

Very low-load engines requiring high levels of isolation.
Portable gensets, compressors, motor pumps...

Type	A (mm)	B (mm)	C (mm)	D (mm)	E (mm)	F (mm)	G (mm)	H (°)	J (mm)	K (mm)	L (mm)	N (mm)	P (mm)	Q (mm)	Weight (gr.)	R (mm)	Code	Load (kg)	Shore
Small	23	14,5	18	18	3	38	15,9	50°	47	23	3	5	5	11	150	M8	148151	5	45 Sh
																	148153	15	60 Sh
Large	28	19,5	22	18	3	38	20	50°	54	31	3	7	10	16	205	M8	148171	40	45 Sh
																	148173	90	60 Sh

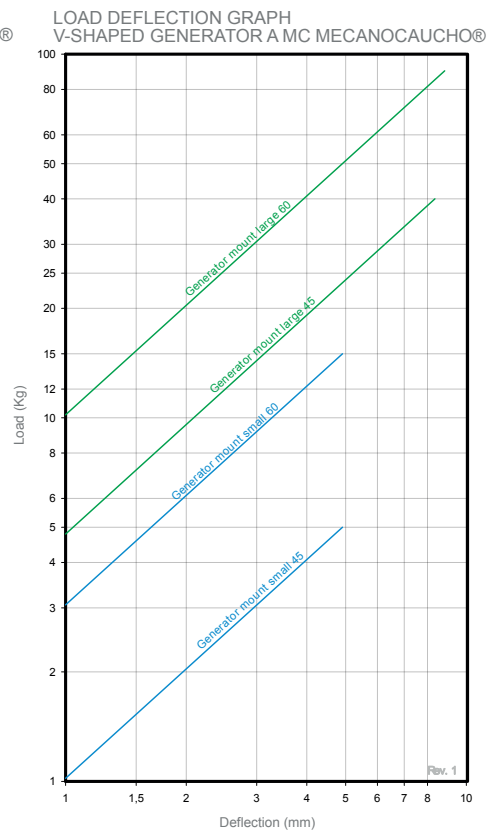
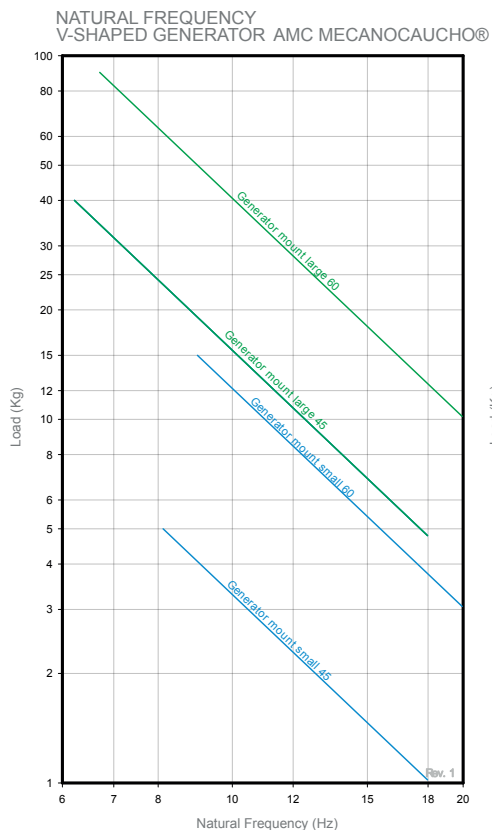

* AMC S.A. reserves the right to modify the design and manufacture of the materials presented in this catalogue without prior notice.

DRD



DESCRIPTION

The AMC MECANOCAUCHO® type DRD mounts have a low axial and radial stiffness rate. Their design makes them ideal for those machines that produce vibrations in the 3 directions. The architecture of these mounts is similar to the DSD, but the rubber section is greater, this feature makes them have a lower stiffness rates than the DSD mounts. These mounts are particularly interesting for those applications where an extra isolation is needed.

OPERATION AND ASSEMBLY

The design of the mount allows an easy installation. The top metal part has an inside thread for securing to the machine, the baseplate has 2/4 holes that allow an easy fixation to the frame. Oil anti-drip hoods can be supplied on demand.

The DRD mounts by MECANOCAUCHO® have the following characteristics.

- The metal parts are protected from corrosion by an electrolytic coating for outdoor work. RoHs compliant.
- We engrave the rubber hardness on the metal parts.

APPLICATIONS

The DRD mounts are ideal for light machines at medium or low excitation frequencies.

- Compressors.
- Air-conditioners.
- Ventilators.
- Vibrating Tables.

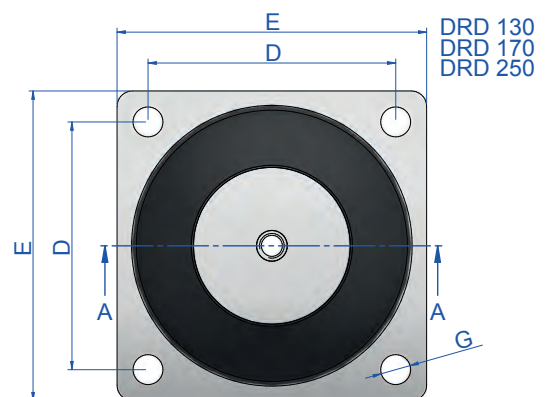
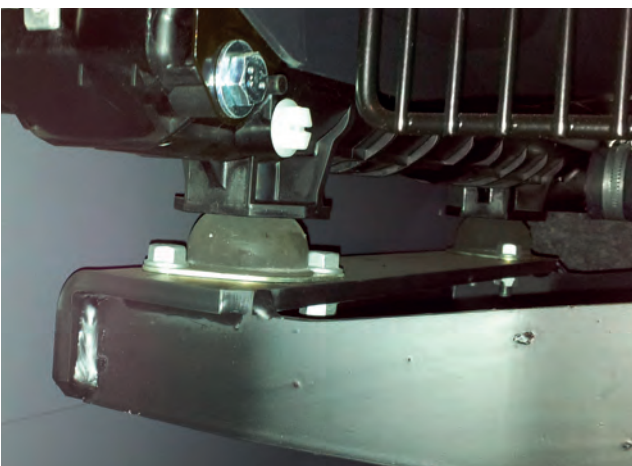
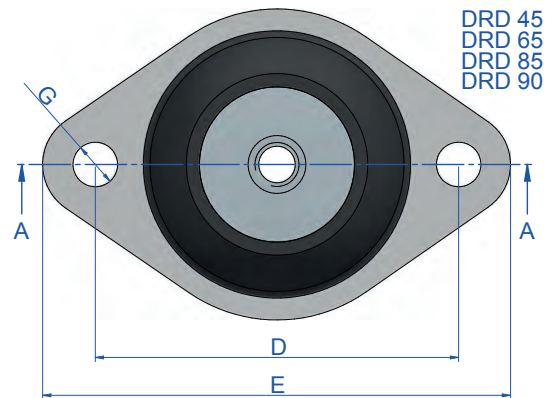
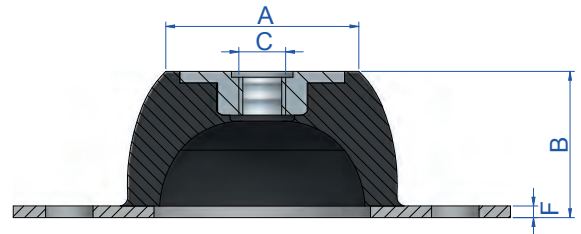

Type	A (mm)	B (mm)	C (mm)	D (mm)	E (mm)	F (mm)	G (mm)	Weight (gr.)	Code	Load (kg)	Shore
DRD 45	33	25	M-8	66	85	2	8	70	175081	20	45 Sh
									175083	50	60 Sh
DRD 65	52	35	M-10	92	114	2,5	10,5	170	175001	40	45 Sh
									175002	75	60 Sh
DRD 85	52	40	M-10	110	136	3	11,5	303	175003	75	45 Sh
									175004	120	60 Sh
									175013	185	75 Sh
DRD 90	57,5	45	M-10	125	150	3	12,5	430	175021	130	45 Sh
									175022	220	60 Sh
									175023	275	75 Sh
DRD 130	78	63	M-12	120	150	5	14,5	1080	175031	280	45 Sh
									175032	500	60 Sh
									175033	625	75 Sh
DRD 170	100	84	M-16	160	200	4	14,5	2390	175036	380	45 Sh
									175037	750	60 Sh
									175038	930	75 Sh
DRD 250	187	158	M-24	250	310	6	18,5	10400	175041	1400	45 Sh
									175042	2500	60 Sh
									175044	3150	75 Sh

NATURAL FREQUENCY
AMC MECANOCAUCHO® TYPE DRD

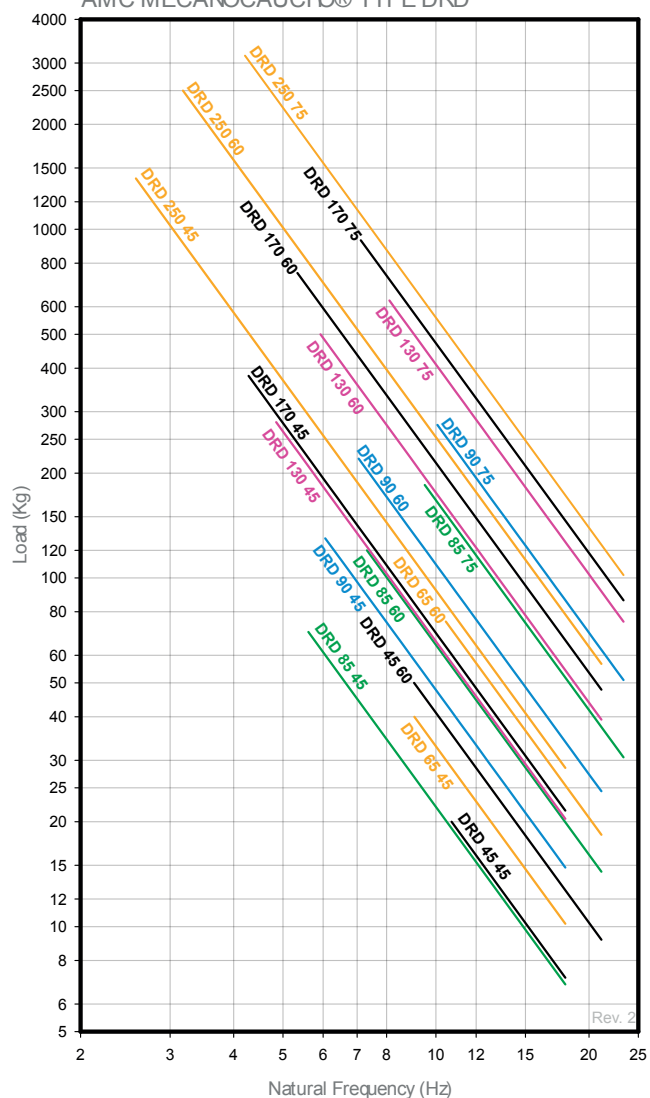

LOAD DEFLECTION GRAPH
AMC MECANOCAUCHO® TYPE DRD

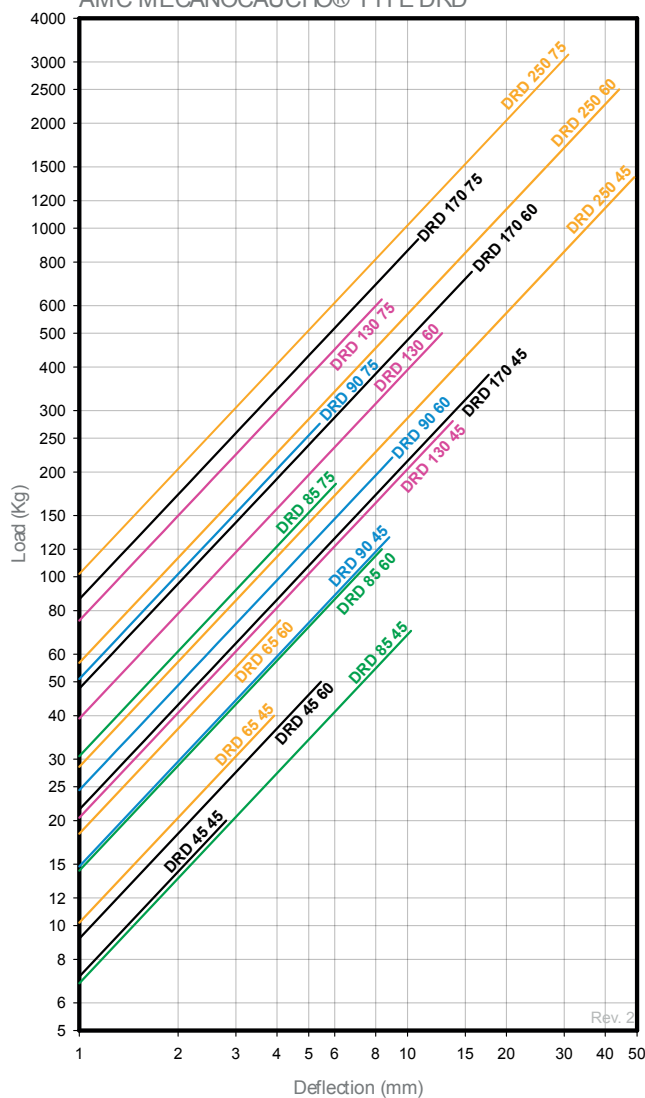

* AMC S.A. reserves the right to modify the design and manufacture of the materials presented in this catalogue without prior notice.

DSD



DESCRIPTION

AMC MECANOCAUCHO® DSD mounts design provides excellent radial and axial flexibility making them most suitable for the suspension of machines where isolation of both vertical and horizontal vibration components occur.

DSD mounts comprise of two flat metal parts. Top metal part is circular with either a tapped central hole or interior welded nut for attachment to the machine frames. Lower metal part has an oval contour with two machined holes, one at each end, to securely attach the mountings to the support structure for the machine.

TECHNICAL CHARACTERISTICS

DSD mountings comparable stiffness vertically and horizontal making them very effective against random vibrations in either plane.

APPLICATIONS

DSD mountings are particularly suitable for applications with low to medium dynamic amplitudes which enables the mountings stiffness rates to provide effective isolation .

Suitable for HVAC, Ventilators, rotating pumps, torque or frequency converters, electrical engines, etc.

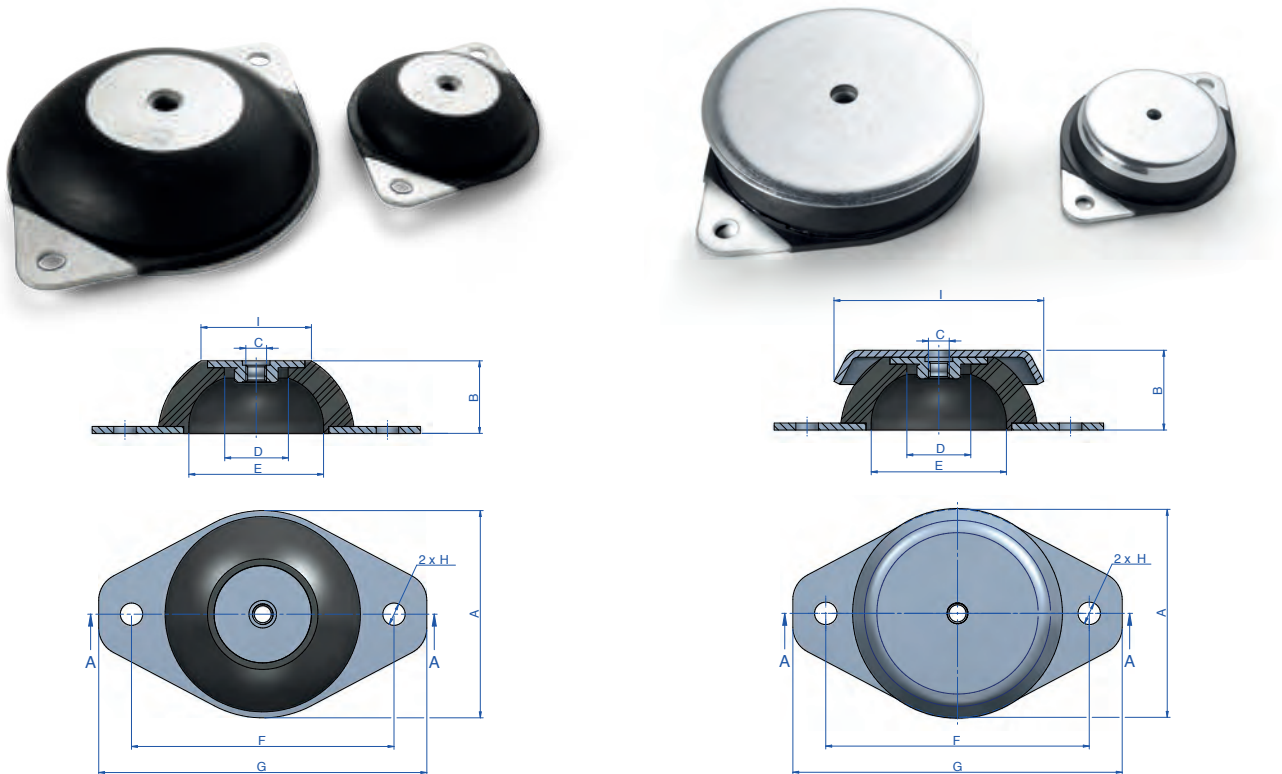

Type	A (mm)	B (mm)	C (mm)	D (mm)	E (mm)	F (mm)	G (mm)	H (mm)	I (mm)	Weight (gr.)	Code	Load (kg)	Shore
DSD 40 + Bell	43	19	M-6	19	29	52	64	6,25	40	48	134028	4	45 Sh
											134029	10	60 Sh
											134030	15	75 Sh
DSD 60 + Bell	60	23	M-6	14	39	76	95	6,5	60,5	128	134031	15	45 Sh
											134032	25	60 Sh
											134033	45	75 Sh
DSD 80 + Bell	86	27	M-8	25	65	100	120	8,5	85	232	134034	75	45 Sh
											134035	110	60 Sh
											134036	150	75 Sh
DSD 100 + Bell	100	28	M-10	22	67	124	149	10,5	103,5	465	134037	90	45 Sh
											134038	160	60 Sh
											134039	220	75 Sh
DSD 150 + Bell	150	37	M-14	34	114	182	214	12	155	1110	134040	130	45 Sh
											134041	250	60 Sh
											134042	350	75 Sh
DSD 200 + Bell	200	44	M-18	35	140	240	280	15	208	2736	134043	500	45 Sh
											134044	825	60 Sh
											134045	1250	75 Sh

Type	A (mm)	B (mm)	C (mm)	D (mm)	E (mm)	F (mm)	G (mm)	H (mm)	I (mm)	Weight (gr.)	Code	Load (kg)	Shore
DSD 40	43	17	M-6	19	29	52	64	6,25	24,5	28	134001	4	45 Sh
											134002	10	60 Sh
											134003	15	75 Sh
DSD 60	60	21	M-6	14	39	76	95	6,5	32	73	134004	15	45 Sh
											134005	25	60 Sh
											134006	45	75 Sh
DSD 80	86	25	M-8	25	65	100	120	8,5	51	130	134007	75	45 Sh
											134008	110	60 Sh
											134009	150	75 Sh
DSD 100	100	25	M-10	22	67	124	149	10,5	54	262	134010	90	45 Sh
											134011	160	60 Sh
											134012	220	75 Sh
DSD 150	150	34	M-14	34	114	182	214	12	76	664	134013	130	45 Sh
											134014	250	60 Sh
											134015	350	75 Sh
DSD 200	200	40	M-18	35	140	240	280	15	128	1615	134016	500	45 Sh
											134017	825	60 Sh
											134018	1250	75 Sh

NATURAL FREQUENCY
AMC MECANOCAUCHO® TYPE DSD

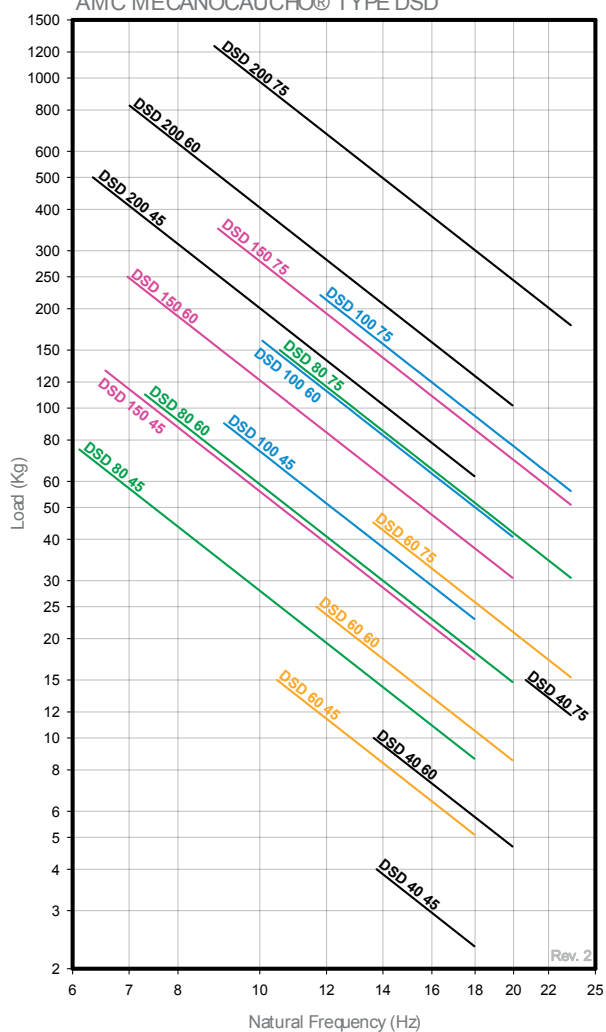

LOAD DEFLECTION GRAPH
AMC MECANOCAUCHO® TYPE DSD

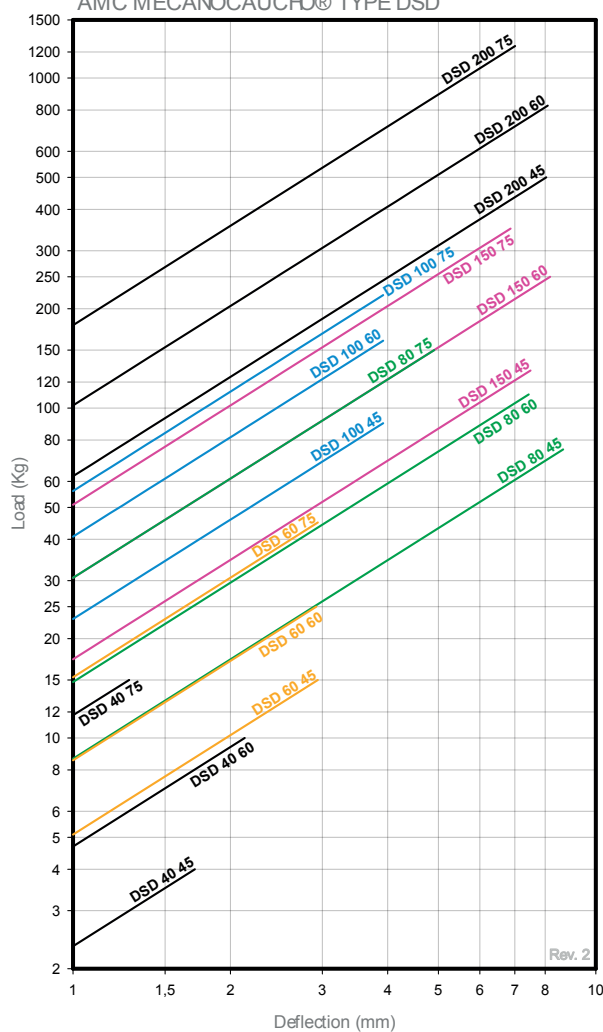



ATP

DESCRIPTION

AMC MECANOCAUCHO® ATP type mounts have been designed to provide effective vibration isolation of medium to high frequency applications in a variety of industrial machinery, gensets, motor pumps, motor compressors, hydraulic units, etc.

The top metal part is cup shaped to protect the rubber section from contamination by oil, grease, petrol, diesel, dust, etc.

TECHNICAL CHARACTERISTICS

The compound used is based on a standard natural rubber specifically designed to have good ageing properties.

Load capacities shown in catalogue are the maximum Static values with the capability of withstanding occasional extreme dynamic overloads .

ATP mounts have stiffness values 4 times greater in the radial plane than the axial plane, providing effective resistance to transient lateral shock loads.

APPLICATIONS

Suspension systems where it is deemed necessary to control any Pitching or Rolling movement which could strain external connections. • Medium and high frequency motor compressor units. • Gen sets. • Hydraulic Units. • Marine auxiliary units. • Ventilators, etc.

Fig. 1

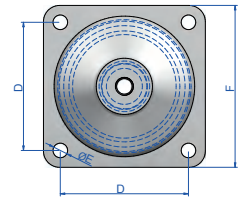
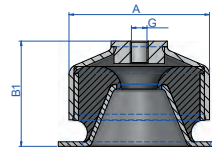
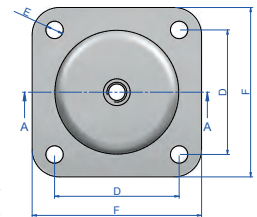
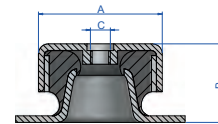

Fig. 2



FOR NEW PROJECTS,
CHOOSE FIG 2 PREFERABLY.

Type	A (mm)	B (mm)	C (mm)	D (mm)	E (mm)	F (mm)	G (mm)	Weight (gr.)	B1	Code	Load (kg)	Shore	Fig.
ATP 020	49,7	31,5	M-8	50	7	68	16	143	-	133101	50	45 Sh	2
										133102	75	60 Sh	2
										133103	100	75 Sh	2
										133104	70	45 Sh	2
ATP 120	73,6	43	M-10	72,2	9,2	90	32	379	53	133105	120	60 Sh	2
										133106	175	75 Sh	2
										133151	70	45 Sh	1
										133152	120	60 Sh	1
										133153	175	75 Sh	1
										133107	140	45 Sh	2
ATP 220	91	53	M-12	90	11	114,2	36	618	63	133108	200	60 Sh	2
										133109	300	75 Sh	2
										133154	140	45 Sh	1
										133155	200	60 Sh	1
										133156	300	75 Sh	1
										133110	300	45 Sh	2
ATP 420	124,5	75	M-16	114	13	144	60	1510	94	133111	500	60 Sh	2
										133112	800	75 Sh	2
										133157	300	45 Sh	1
										133158	500	60 Sh	1
										133159	800	75 Sh	1
										133113	500	45 Sh	2

NATURAL FREQUENCY
AMC MECANOCAUCHO® ATP

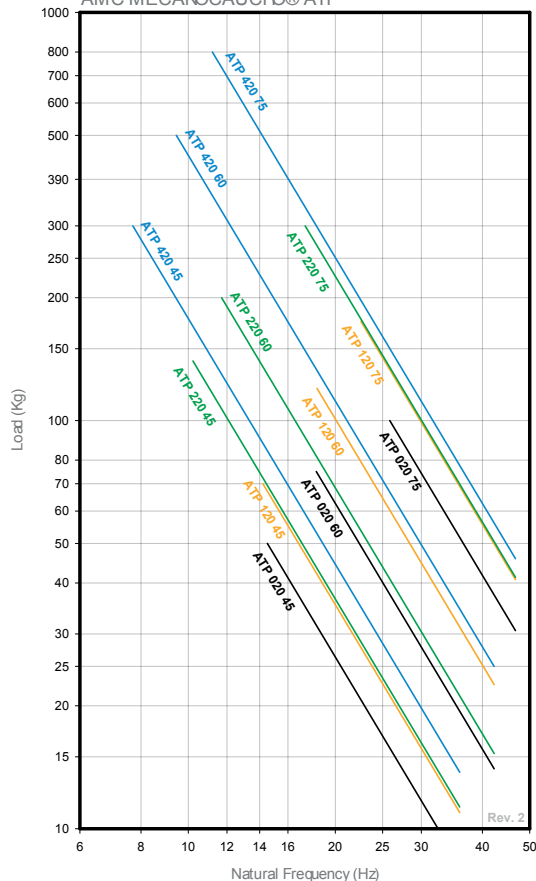

LOAD DEFLECTION GRAPH
AMC MECANOCAUCHO® ATP

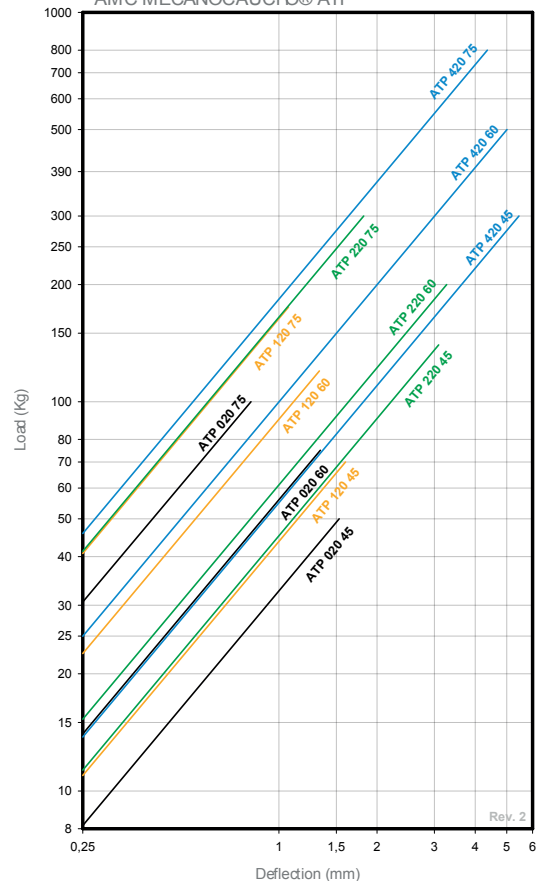

TRANSFORMER MOUNTS



DESCRIPTION

The AMC MECANOCAUCHO® TRANSFORMER MOUNT combines a spring and a TRANSFORMER MOUNT damper in a single compact unit. This mount is particularly useful for transformer where isolation is needed.

The internal architecture of the mount is composed of a system that bonds the rubber to both metal parts.

TECHNICAL CHARACTERISTICS

- The AMC MECANOCAUCHO® TRANSFORMER MOUNT incorporates resilient natural rubber specifically designed to last over time.
- The metal parts have a suitable anticorrosive treatment for outdoor applications.
- The load capacity shown in our catalogue is the maximum static values the transformer mount can support, with the capability of withstanding occasional extreme dynamic overload.

APPLICATIONS

The AMC MECANOCAUCHO® mounts have been primarily designed as transformer mounts.

The shape of the upper metal plate allows for the accommodation of the transformer wheel. This characteristic permits an easy installation without any additional fastening system.

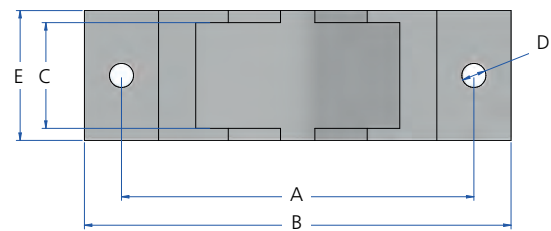
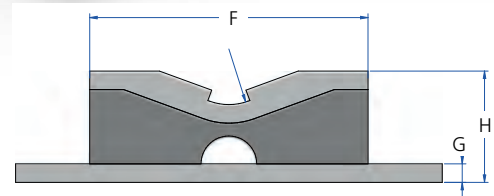

Type	A (mm)	B (mm)	C (mm)	D (mm)	E (mm)	F (mm)	G (mm)	H (mm)	Code	Weight (gr.)	Max. Load (kg)
Small	190	230	57	13	70	150	10	60	148301	2600	800
Large	290	330	88	13	100	250	10	70	148311	5800	3000

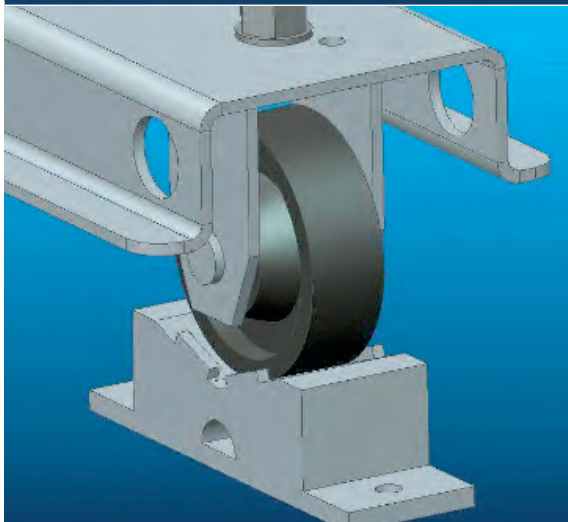
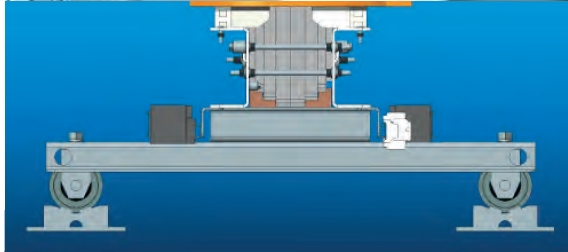

LOAD DEFLECTION GRAPH
AMC MECANOCAUCHO® TRANSFORMER MOUNTS

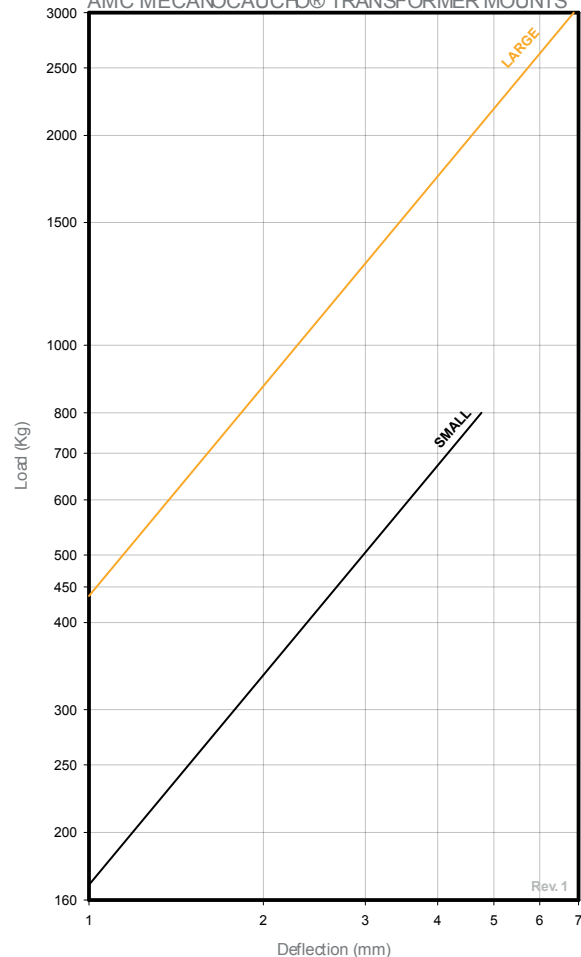

ELASTOMERIC SPRINGS



DESCRIPTION

The AMC-MECANOCAUCHO® type Elastomeric Spring anti vibration mounts are ideal for those applications where high vibration isolation is required. Its specific design allows this mount to have high deflection. This feature is particularly useful on those applications where vibration in the vertical sense is predominant.

TECHNICAL CHARACTERISTICS

The damping properties of the rubber allow to provide a higher motion control of the suspended element. The optimal corrosion properties allow this mount to resist to aggressive corrosion environments.

APPLICATIONS

The AMC-MECANOCAUCHO® Elastomeric Spring anti vibration mounts are used in applications where a high degree of isolation is required and also motion control of the suspended element is required, such as : vibrating tables, vibration feeders or suspension of industrial vehicles.

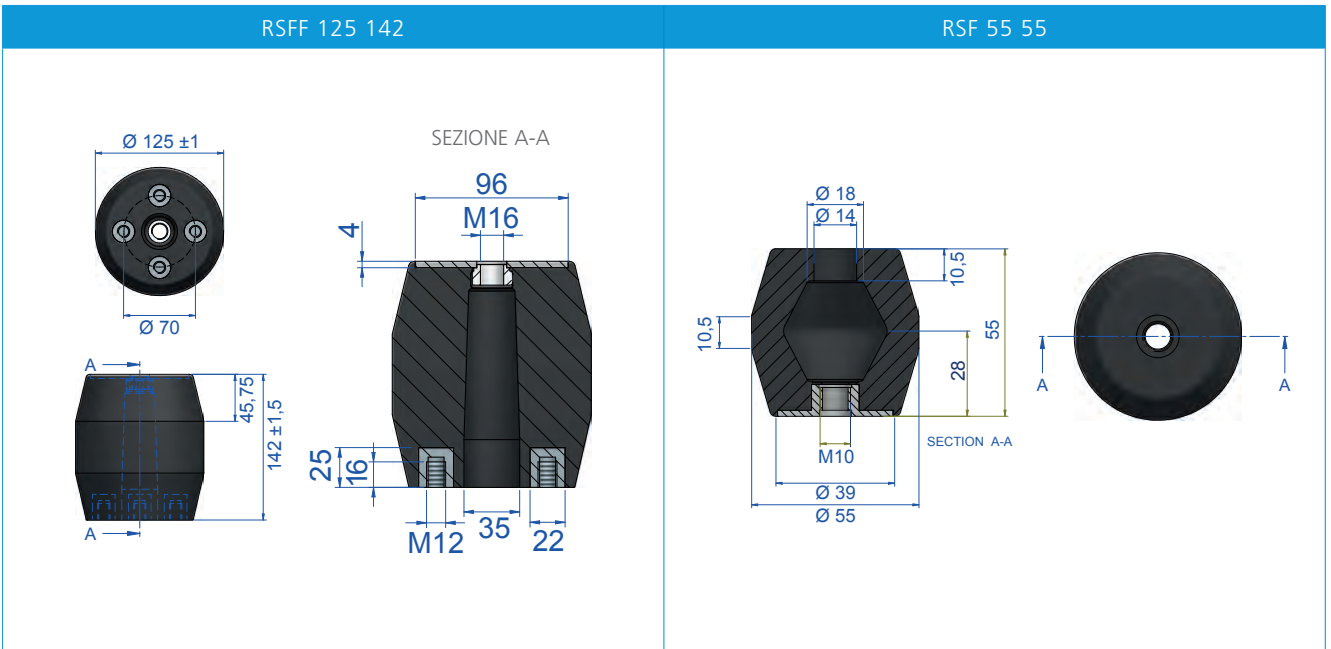

Type	Code	Weight (kg)	Shore	Load max.	Max. Shock
RSFF 125 142	180251	1,953	55 Sh	1150 Kg	-
RSF 55 55	180177	0,123	65 Sh	60 Kg	120 Kg

Load vs Deflection

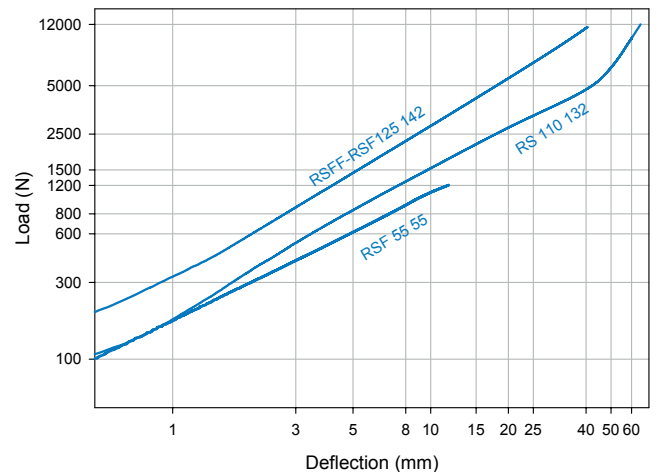

REINFORCED ELASTOMERIC SPRINGS

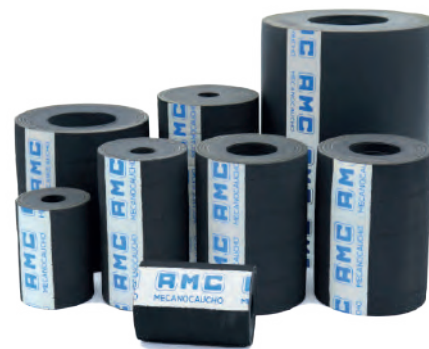

These fabric and rubber springs will provide a long life, greater productivity, fast replacement time and virtually maintenance free operation.

They can be used as a replacement for steel coil springs or an additional anti-vibration device. Unlike coil springs they will not deteriorate in humid or corrosive environments.

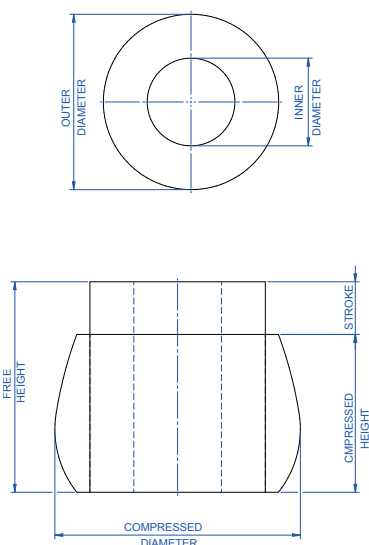

Type	Øext (mm)	Øint (mm)	Free Height (mm)	Load Min (kg)	Compressed Height kg min. (mm)	Freq. Min Load (Hz)	Load Max (kg)	Compressed Height kg max (mm)	Freq. Max Load (Hz)	Code
Reinforced elastomeric springs	41,3	16	44,5	48	38	3,72	120	32	7	171322
	41,3	16	89	49	75	4,08	100	64	3,92	171323
	76	25	102	192	86	3,99	409	74	4,52	171300
	89	25	152	250	130	3,21	513	112	3,28	171303
	102	50	152	284	130	3,21	569	112	3,14	171302
	114	50	152	483	130	3,37	968	114	3,4	171304
	114	25	178	636	152	3,23	1253	133	3,34	171305
	127	25	178	663	152	3,87	1525	129	4,05	171306
	140	50	178	746	152	3,4	1714	129	3,07	171309
	152	76	152	745	130	3,42	1799	112	3,2	171307
	165	76	203	890	173	3,03	1883	152	3,14	171308
	152	25	152	1018	130	3,9	2489	112	3,77	171310
	191	89	203	1143	173	2,3	2815	147	3,24	171314
	191	89	254	1138	216	2,66	2668	184	2,96	171315
	203	50	203	1407	173	3,56	3863	152	3,15	171316
279	51	152	3718	130	3,66	9070	110	3,40	171320	

* AMC S.A. reserves the right to modify the design and manufacture of the materials presented in this catalogue without prior notice.

ECCENTRIC BUSHINGS



DESCRIPTION

On the eccentric bushings the center points of the inner and outer cylinders are not the same. As a result it is more flexible in the direction of the main load and it keeps the same control in the other direction.

TECHNICAL CHARACTERISTICS

- Optimal vibration damping and isolation.
- Fit to use for robust and safe constructions.
- Simple installation and application.

APPLICATION

The AMC MECANOCAUCHO® eccentric bushing is best suited to the following situations and applications:

- Tilting cab suspension.
- Suspension arms.

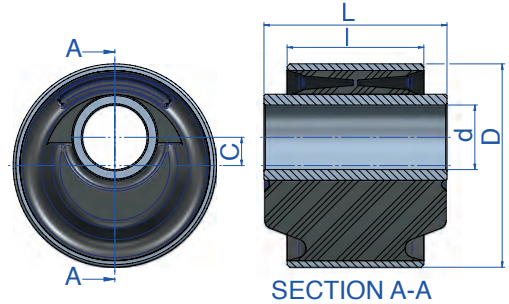

Type	d (mm)	C (mm)	D (mm)	I (mm)	L (mm)	Code	Shore	Max. Load (kg)
MINI	16	7,1	47,6	50,8	63,5	154161	45	110
						154163	60	180
SMALL	24	10,5	75,3	50,8	68	154159	45	200
						154158	60	390
LARGE	43,7	9,5	101,6	63,5	72,4	154154	45	290
						154155	60	510
Ø90						154136	65	350
100 HD						154181	50	225
						154182	55	290
						154183	66	350
100 RD						154175	50	450

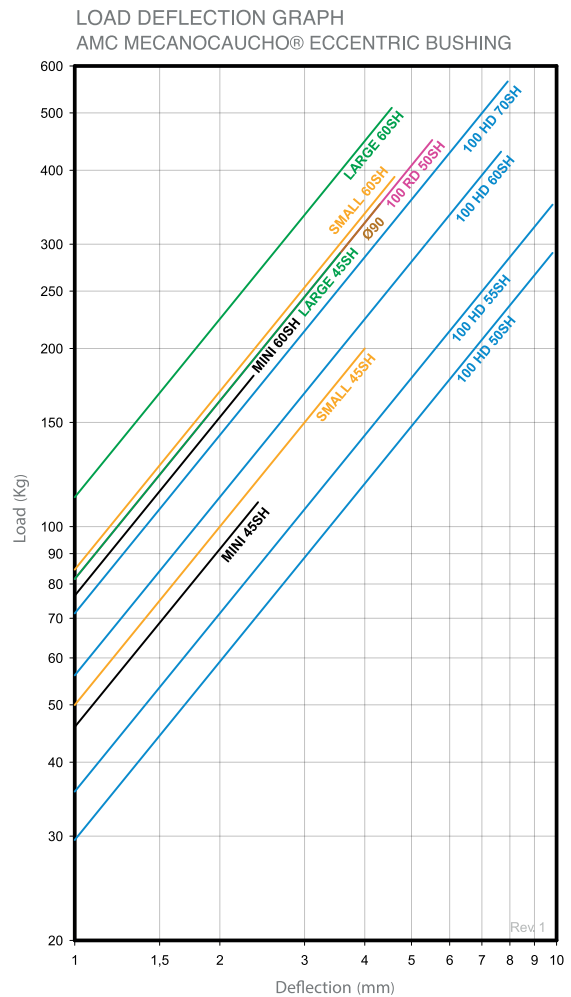
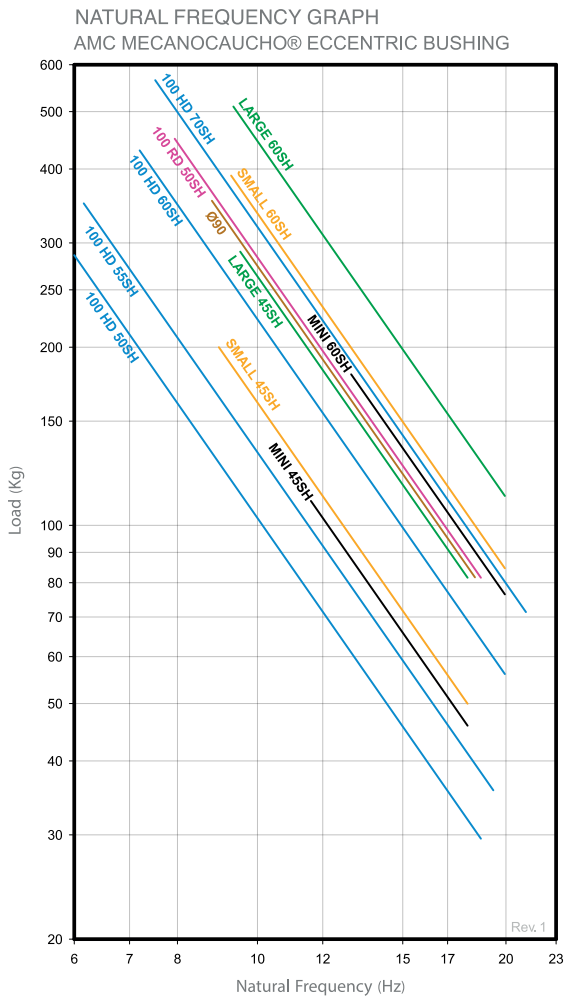

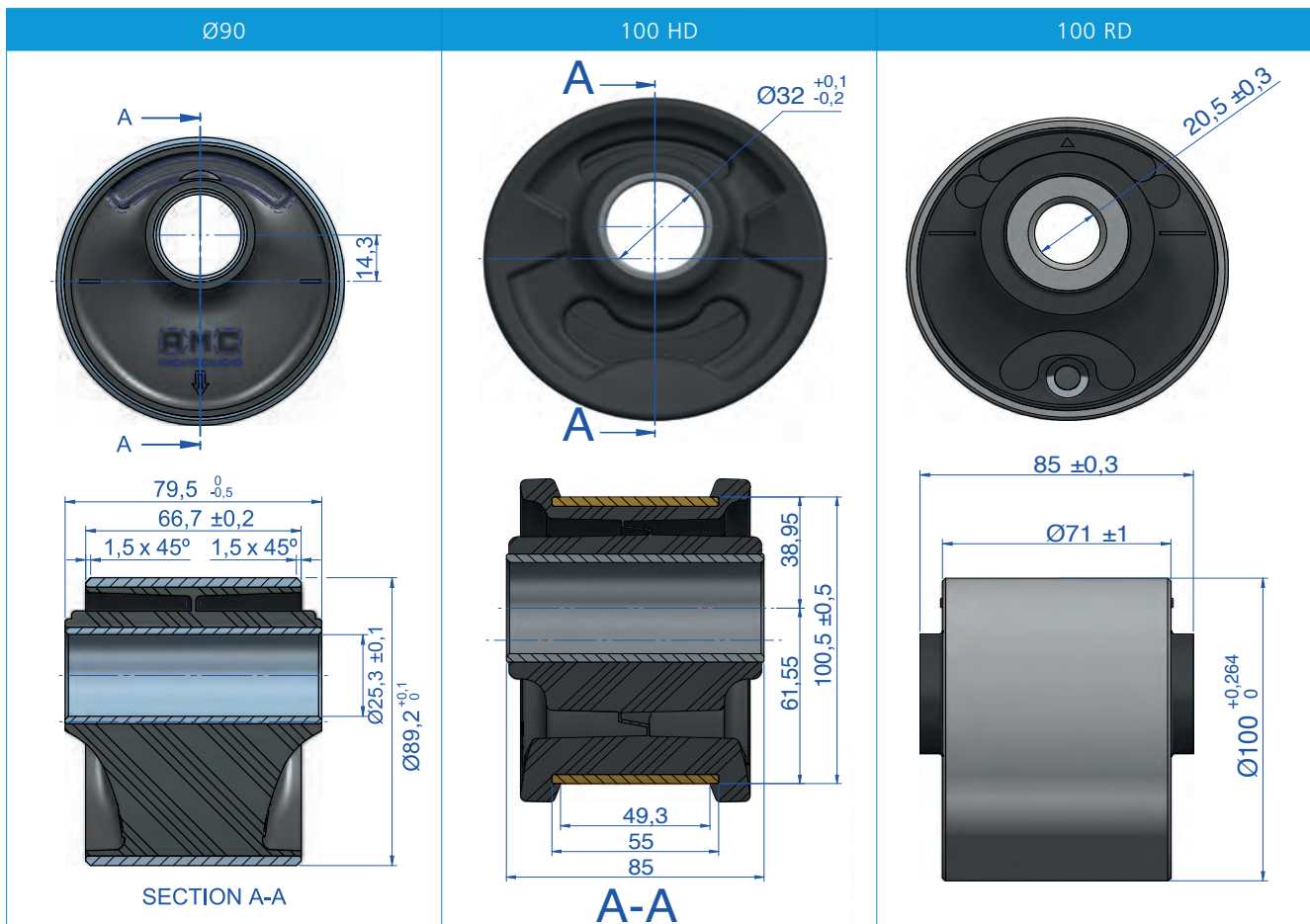

AMC MECANOCAUCHO® BUSHINGS

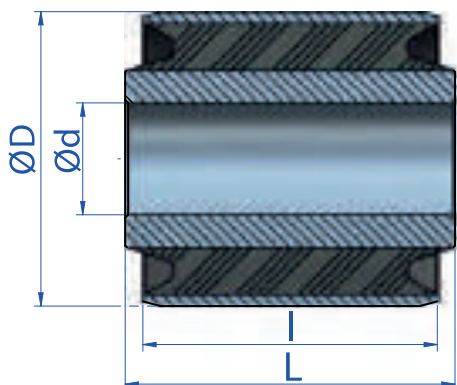

Type	d (mm)	D (mm)	l (mm)	L (mm)	Weight (kg)	Torsion Mt max (Nm)	Angle Torsion ϕ max (°)	Conical Angle max β (°)	Axial load Fa max (N)	Axial load Sa max (mm)	Radial load Fr max (N)	Radial load Sr max (mm)	Code
BUSHINGS	10	22	25	30	0,034	7	10	3	500	0,9	1875	0,25	154005
	10	22	30	32	0,038	9	10	2	600	0,9	2250	0,25	154006
	10	25	20	25	0,60	8	10	3	250	1	2000	1	154168
	12	30	28	34	0,064	10	15	2	580	1,7	1750	0,55	154103
	12	32	55	59	0,131	19	16	2	1200	1,7	7000	0,65	154077
	12	40	40	60	0,198	16	20	3	450	1,8	1200	1	154104
	12.20	46.4	52	60	0,264	33	25	3	1100	2,6	3000	0,85	154086
	14	27	40	45	0,08	20	10	2	935	1,3	4400	0,35	154107
	16	32	22	30	0,073	14	10	3	750	1,3	1800	0,35	154080
	18	36	48,5	58,5	0,161	35	10	2	1420	1,6	7350	0,45	154021
	20	45	35	40	0,152	45	15	2	1600	4,8	5800	1,4	154133
	20	45	64	70	0,285	55	15	2	2200	2,5	10000	0,85	154073
	24	45	44	55	0,265	55	11	3	1840	1,8	8650	0,6	154082
	25	50	50	56	0,261	34	6,6	2	2900	3	10000	1	154040
	25	50	80	85	-	49	14	2	7500	7,8	18000	1,7	154044
	32	66	47	55	0,517	77	15	3	2450	3,9	8400	1,3	154079
	40	70	55	65	0,616	138	12	3	3320	3,6	20500	1,2	154043
	45	75	90	100	0,956	320	10	2	6300	3,1	35000	0,9	154075
45	80	45	45	0,522	80	11	4	1500	3,3	7800	2,3	154091	
50	80	100	110	1,4	450	9	1	7800	2,8	55000	0,85	154061	

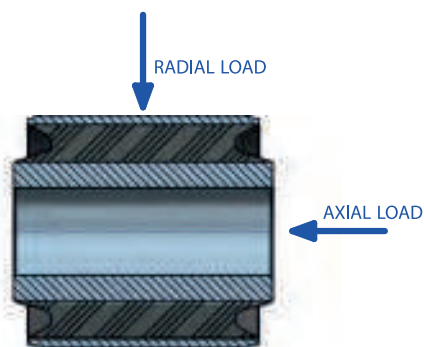

LOADS

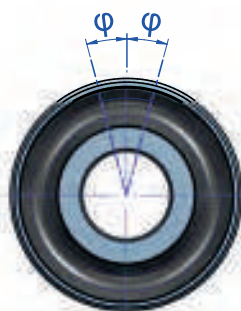

TORSIONAL ANGLE

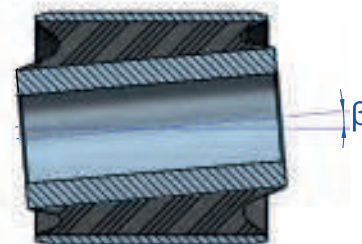

CONICAL ANGLE

SANDWICH ANTI VIBRATION MOUNTS



The AMC-MECANOCAUCHO® type Sandwich anti vibration mounts are ideal for static or mobile applications for loads ranging from 50 to 1500kg.

The Sandwich anti vibration mounts consists of three metal plates joined by two rubber blocks.

This is particularly interesting for mobile applications where the vertical movement has to be controlled.



Type	Shore	Weight (kg)	Max. Load (kg)	Code
Sandwich-46x70x35	40Sh	0,332	80	180199
	55Sh	0,332	150	180187
Sandwich-175x51x35	45Sh	0,775	500	148189
	60Sh	0,775	1000	148190
	70Sh	0,775	1500	148191

Sandwich-46x70x35

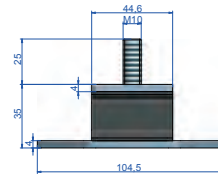

Sandwich-175x51x35

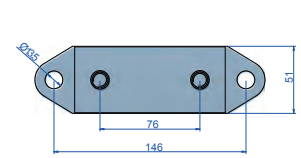
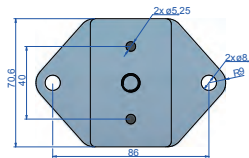
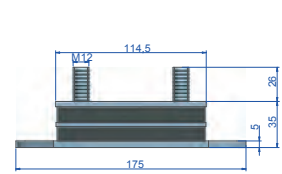

NATURAL FREQUENCY
AMC MECANOCAUCHO® SANDWICH

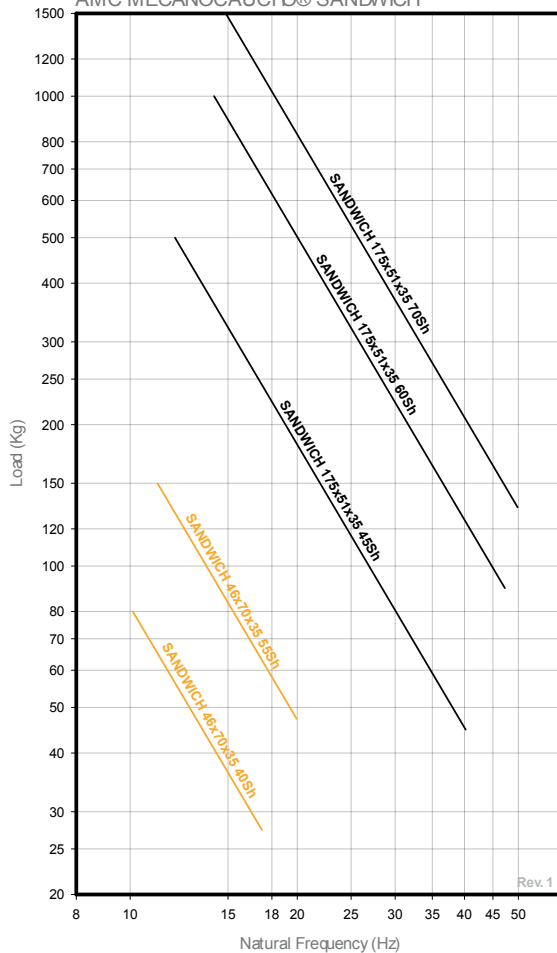

LOAD DEFLECTION GRAPH
AMC MECANOCAUCHO® SANDWICH

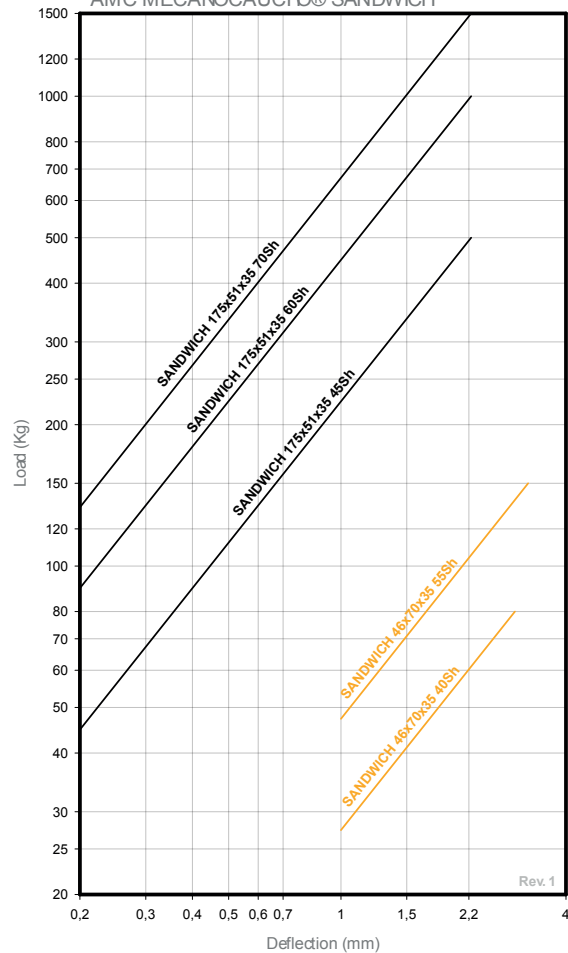

* AMC S.A. reserves the right to modify the design and manufacture of the materials presented in this catalogue without prior notice.



SH

DESCRIPTION

Each mount consists of two heavy duty square outer plates with corner hole fixings fully bonded to circular profiled rubber layers separated by interleaf plates.

The AMC MECANOCAUCHO® type SH mounts provide high static and shock load capacities in compression with a minimum deflection, maintaining a low shear stiffness rate.

TECHNICAL CHARACTERISTICS

The AMC MECANOCAUCHO® type SH mounts are designed for long lasting heavy duty applications.

They can be supplied in 3 different hardness and 3 different sizes to suit applications where the compression load per mount is between 2 to 40 Tons.

APPLICATIONS

High compression capacity, low shear stiffness and relatively low installed heights make the mounts ideal for: Vibratory rollers, Mills, Presses, Heavy machinery, Feeder screens.

Due to their high load capacity these mounts are also used as point bearings for the vibration isolation of building structures.

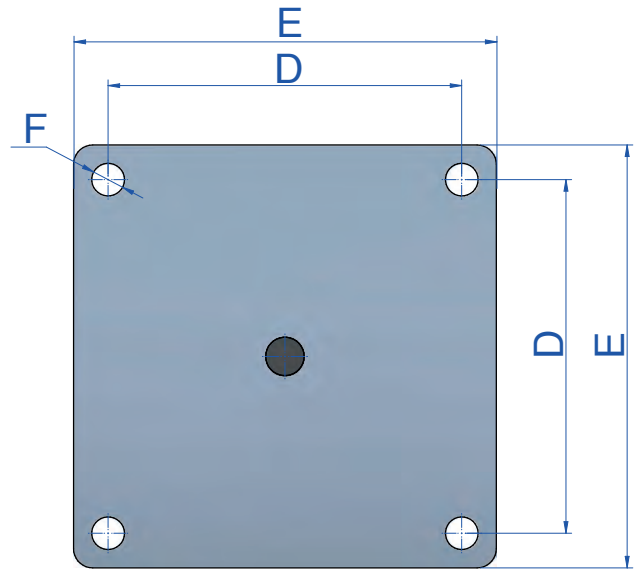
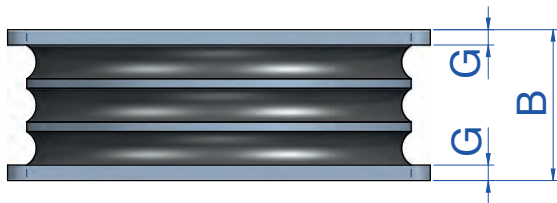

Type	B (mm)	D (mm)	E (mm)	F (mm)	G (mm)	Weight (kg)	Code	Shore	Max. Load (kg)
SH 125	52	118	148	13,5	5	2,5	148213	45 Sh	2250
							148215	60 Sh	4500
SH 150	63	136	166	13,5	6	4,5	148201	45 Sh	3750
							148202	60 Sh	7500
SH 200	78,5	184	220	17	8	9	148204	45 Sh	6000
							148205	60 Sh	12000
SH 300	120	270	310	22	10	27	148207	45 Sh	15000
							148208	60 Sh	30000
							148209	70 Sh	40000

“VEE” INCLINED INSTALLATION CONFIGURATION

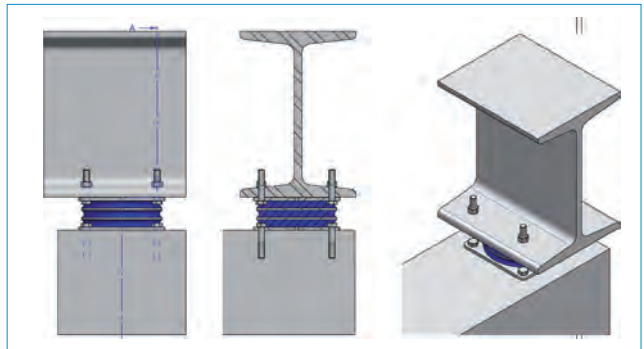
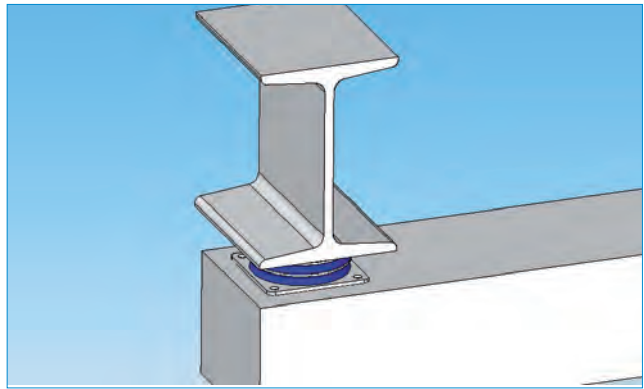
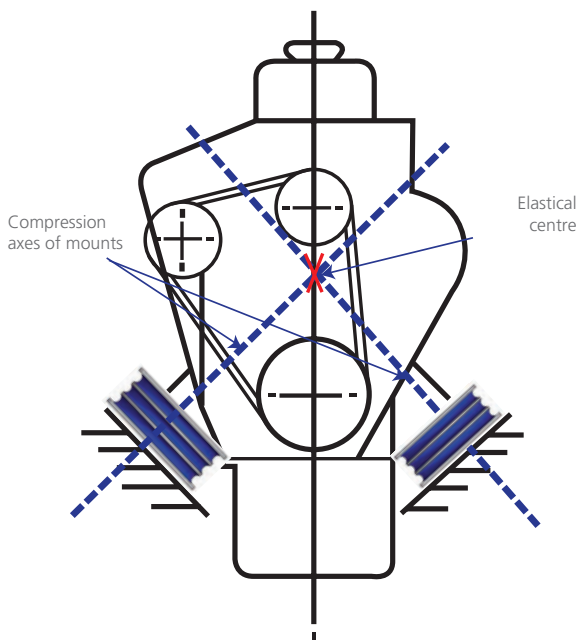

AMC MECANOCAUCHO® technical department can calculate a precise angle configuration in order to achieve an optimum compromise between isolation and stability of the suspended equipment

NATURAL FREQUENCY
AMC MECANOCAUCHO® SH

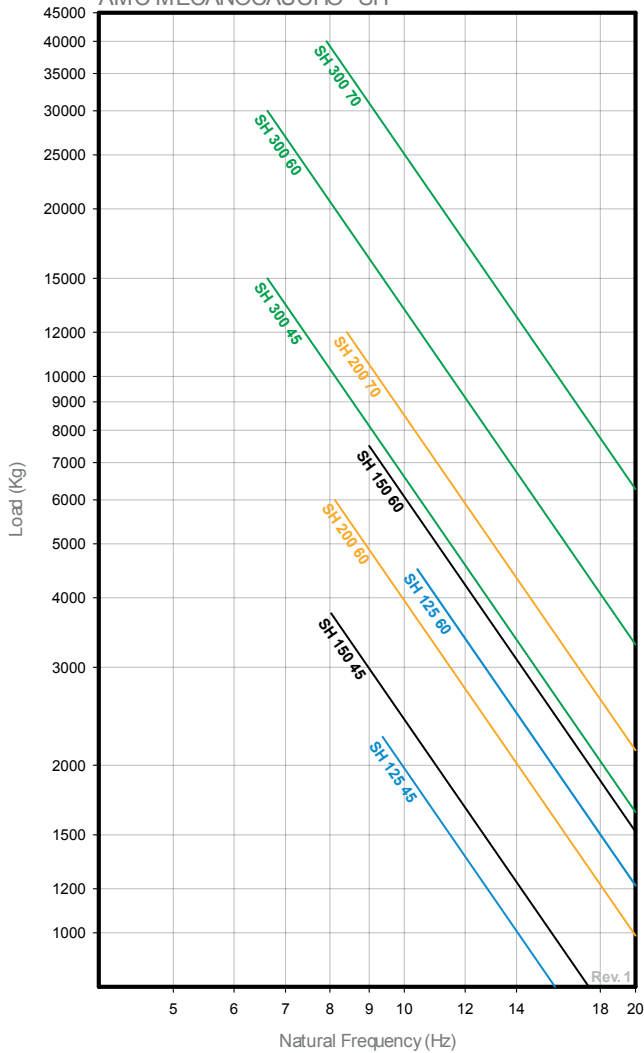

LOAD DEFLECTION GRAPH
AMC MECANOCAUCHO® SH

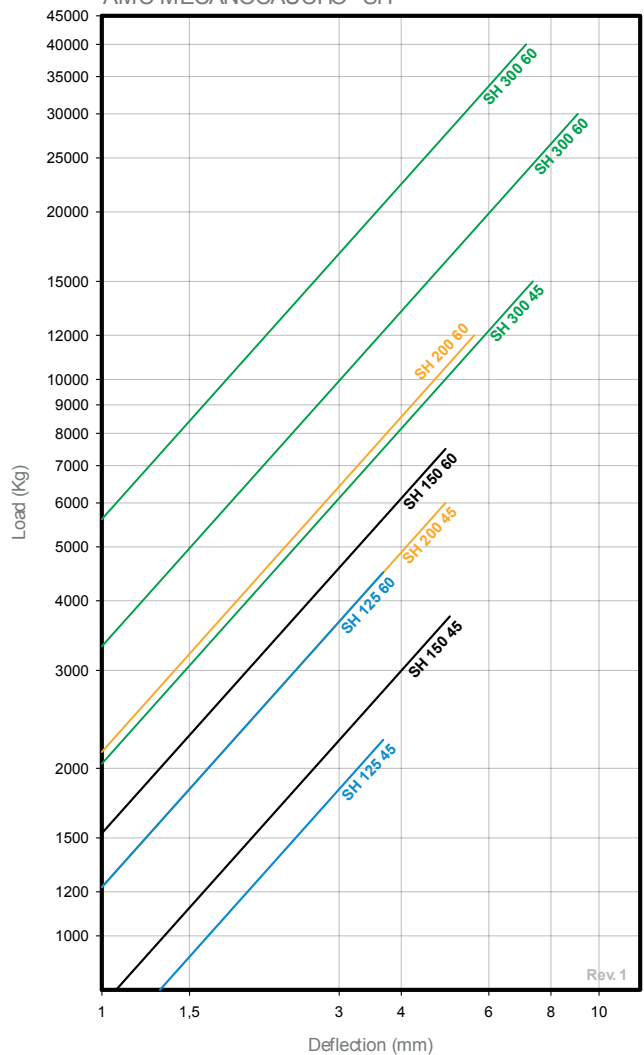

MOUNTS FOR LARGE LOADS

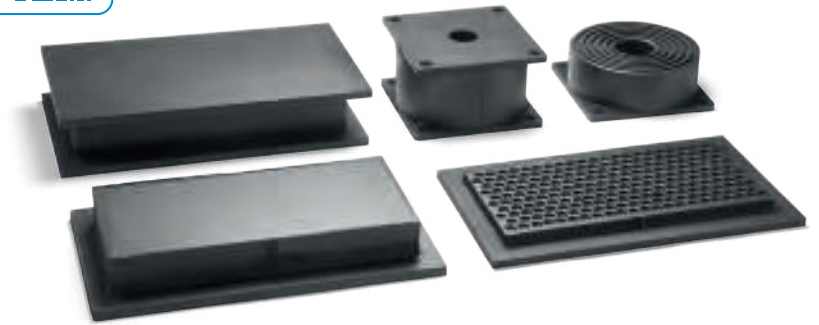

AMC MECANOCAUCHO® ANTI-SKID B

Type	Code	Load (kg)	Deflection (mm)
ANTI-SKID B	141003	8.000	3

AMC MECANOCAUCHO® TYPE B

Type	Code	Load (kg)
Type B	141004	10000

AMC MECANOCAUCHO® TYPE P

Type	Code	Weight (kg)	Max. Load (kg)
Type P	141005	2.500	15

AMC MECANOCAUCHO® TYPE ANTI-SKID P

Type	Code	Deflection (mm)	Max. Load (Kg)
ANTI-SKID P	141006	400x400	6

AMC MECANOCAUCHO® TYPE S

Type	A (mm)	B (mm)	C (mm)	D (mm)	E (mm)	F (mm)	Deflection (mm)	Code	Max. Load (kg)
L-40	300	40	20	350	140	200	5	141021	15000
L-50	300	50	30	350	140	200	5	141022	13000
L-60	300	60	40	350	140	200	5	141023	11000
L-70	300	70	50	350	140	200	5	141024	9000

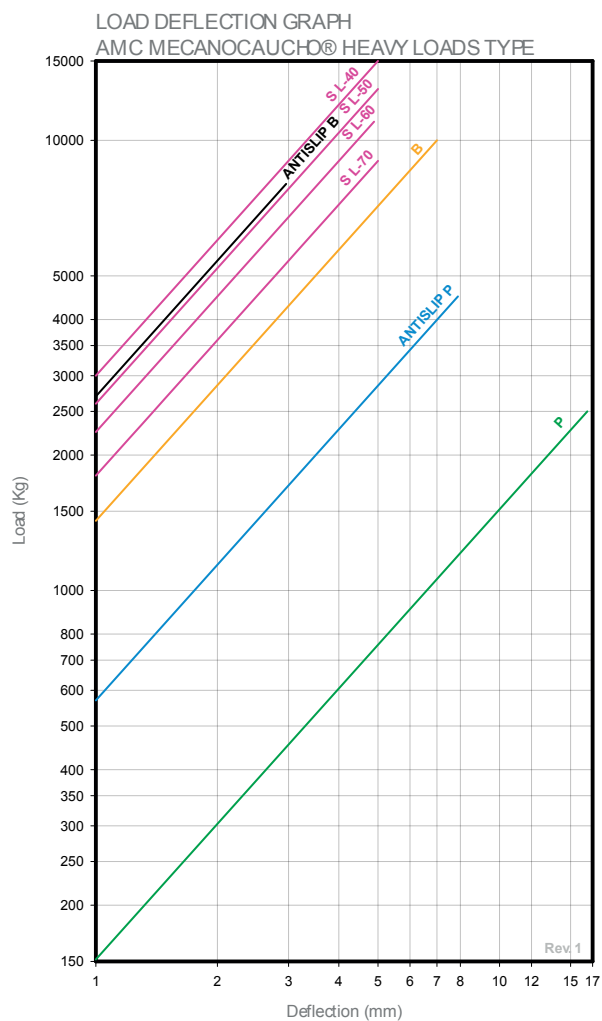
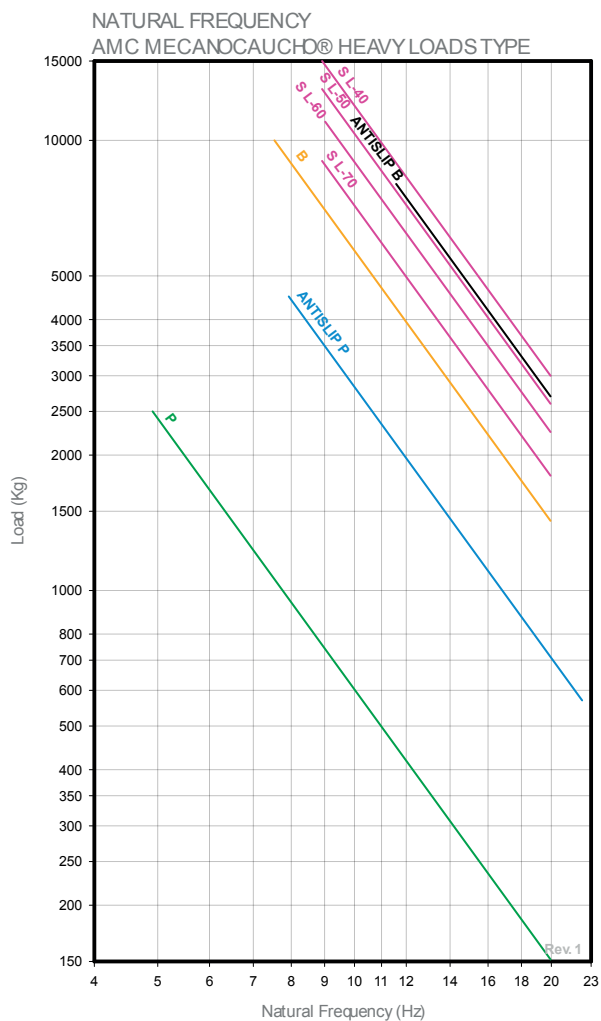
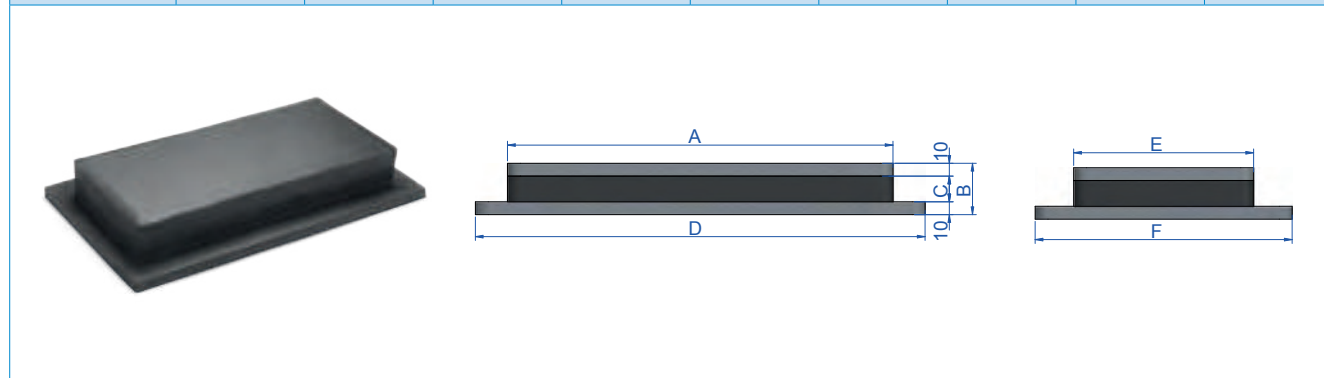

NF LEVELLING MACHINE MOUNTS

The N.F.-type AMC MECANOCAUCHO® mounts are used in cases where light or heavy machines should not be fixed to the floor or ground.

The height adjustment system can be used to adjust the machines to the required level, thus insulating from vibrations and reducing noise. The AMC MECANOCAUCHO® type NF comes with a tilting system allowing optimum adaptation to all surfaces.

The elastomer used is a mixture of oil-resistant synthetic Nitrile Butadiene Rubber (NBR).

Height is adjusted by means of a screw, although this operation can even be performed once the machine has been assembled. The wide contact between the base of the machine guarantees good overall stability.

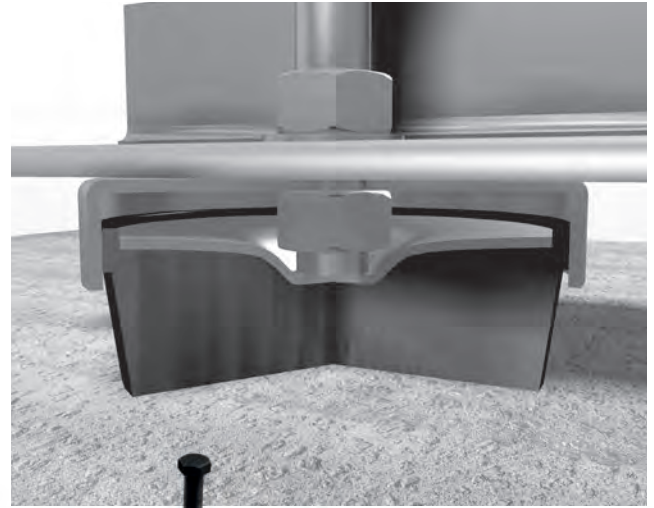

AMC MECANOCAUCHO® TYPE NF

Type	A (mm)	B mm Min	B mm Max	B mm adjustment	Static load Nominal kg	Deflection (mm)	Weight (gr.)	Code	C	H Min (mm)	H Max (mm)	Fig.
NF-65	65	27	34	7	320	2	349	142001	M-12x1,75	105	110	1
								142017	M-12x1,75	78	85	2
NF-85	85	33	46	13	650	2	732	142002	M-16x2	114	127	1
								142018	M-16x2	82	95	2
NF-100	100	35	48	13	980	2	960	142003	M-16x2	120	130	1
								142019	M-16x2	82	95	2
NF-130	130	45	58	13	2500	3	1675	142004	M-20x2,5	130	140	1
								142023	M-16x1,5	67	80	2
								142028	M-16x1,5	99	112	2
NF-160	160	53	66	13	4000	3	3397	142005	M-20x2,5	130	140	1
								142024	M-20x1,5	62	75	2
								142026	M-20x1,5	135	145	2
NF-200	200	55	68	13	5000	3	4958	142006	M-24x3	158	176	1
								142025	M-24x1,5	158	176	2
								142027	M-24x1,5	81	94	2
NF-250	250	67	85	18	7000	3	8575	142007	M-30x2	153	176	1

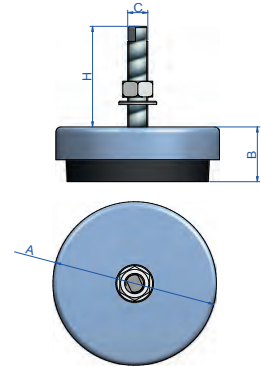

AMC MECANOCAUCHO® TYPE NFR

Type	A (mm)	B (mm)	C (mm)	H mm Min	Static load Nominal kg	Deflection mm	Fig.	Code	Weight (gr.)
NFR-85	85	33	M-16	100	650	2	2	142009	713
NFR-100	100	35	M-16	100	980	2	2	142010	929
NFR-130	130	45	M-20	130	1350	3	3	142011	1832
NFR-160	160	53	M-20	130	2500	3	3	142012	3330
NFR-200	200	55	M-24	140	3700	3	1	142013	4924

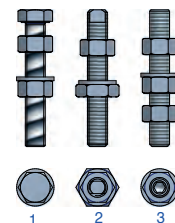
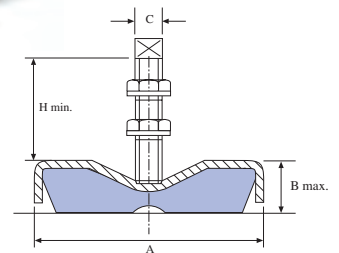

SV



APPLICATIONS

The SV-type AMC MECANOCAUCHO® mounts are used in cases where light or heavy machines are not fixed to the floor or ground. The height adjustment system can be used to adjust the machines to the required level, thus insulating areas nearby from vibrations and reducing noise.



Type	A (mm)	B (mm)	C (mm)	D (mm)	Load kg min.	Load kg max.	Code	Weight (gr.)
000	45	23	M-8	48	20	80	143001	91
00	60	28	M-10	81	60	120	143002	235
0	70	34	M-12	89	90	160	143003	350
1	85	32	M-12	89	130	350	143004	456
2	100	40	M-14	109	270	600	143005	702
3	120	37	M-16	116	450	900	143006	954
4	140	55	M-16	116	700	1200	143007	1513
5	160	60	M-16	116	1100	1750	143008	1865
6	180	70	M-24	138	1500	2500	143009	3034
7	210	75	M-24	138	2100	3750	143010	4248

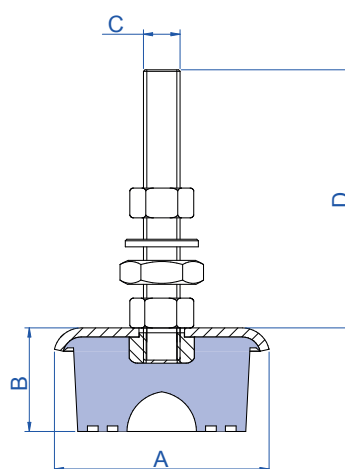

* Can be supplied in stainless steel.

AMC MECANOCAUCHO®
TYPE JT



APPLICATIONS: Levelling machine mounts

Type	Code	Load (kg)	Weight (gr.)	Shore
JT Type	144001	25-40	53	50 Sh
	144002	75-100	53	75 Sh

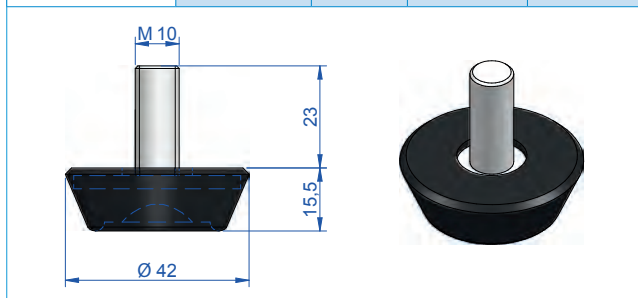

AMC MECANOCAUCHO®
TYPE SX



APPLICATIONS: Levelling machine mounts

Type	Shore	Code	Load (kg)	Weight (gr.)
SX Type	50 Sh	145001	10-25	25

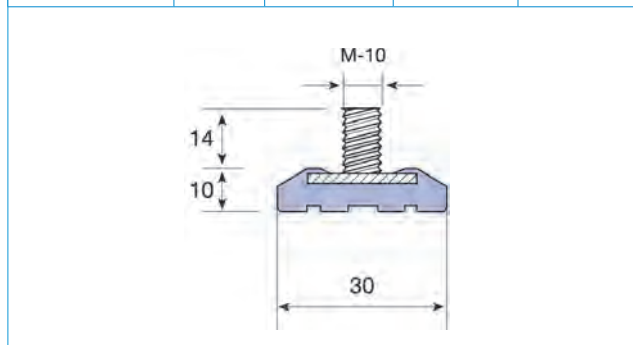

LOW SV



APPLICATIONS

The LOW SV-type AMC MECANOCAUCHO® anti vibration mounts are used in cases where light or heavy machines are not fixed to the floor or ground. The height adjustment system can be used to adjust the machines to the required level, thus insulating areas nearby from vibrations and reducing noise.



Type	A (mm)	B (mm)	C (mm)	D (mm)	Load kg min.	Load kg max.	Code	Weight (gr.)
000 B	43	16	M-8	45	40	80	147000	257
00 B	60	18	M-10	81	60	120	147001	334
0 B	70	20	M-12	89	90	160	147002	286
1 B	84	25	M-12	88	130	350	147003	382
2 B	100	20	M-14	109	270	600	147004	574
3 B	120	25	M-16	116	450	900	147005	867
4 B	140	33	M-16	116	700	1200	147006	1300
5 B	160	36	M-16	116	1100	1750	147007	1556
00 B STAINLESS STEEL	60	18	M-10	81	60	120	147014	334
0 B STAINLESS STEEL	70	20	M-12	89	90	160	147013	286
1 B STAINLESS STEEL	85	25	M-12	89	130	350	147012	382
2 B STAINLESS STEEL	100	20	M-14	109	270	600	147015	574
3 B STAINLESS STEEL	120	25	M-16	116	450	900	147011	867
4 B STAINLESS STEEL	140	33	M-16	116	700	1200	147016	1300
5 B STAINLESS STEEL	160	36	M-16	116	1100	1750	147017	1556

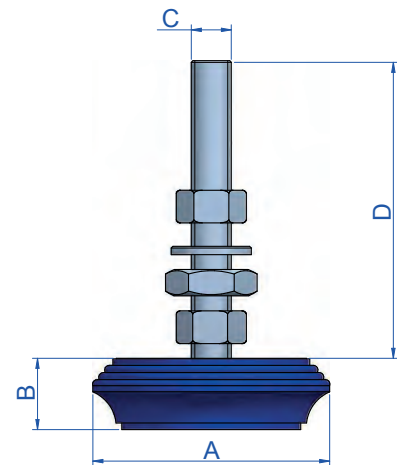

AMC MECANOCAUCHO® TYPE SM

APPLICATIONS: Levelling machine mounts.



Type	A (mm)	B (mm)	C (mm)	D (mm)	Load kg max.	Code	Weight (gr.)
S.M.-40	40	18	M-8	48	45	146001	79
S.M.-60	65	28	M-12	89	150	146002	307
S.M.-70	75	29	M-12	89	250	146003	363
S.M.-90	95	30	M-12	89	500	146004	573
S.M.-120	125	31	M-16	116	1000	146005	904

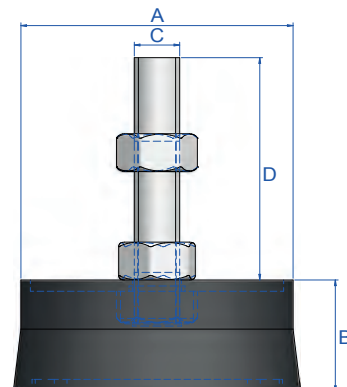

AMC MECANOCAUCHO® ELASTIC COUPLINGS



AMC MECANOCAUCHO ELASTIC COUPLINGS FLECTOR

X-X' SECTION

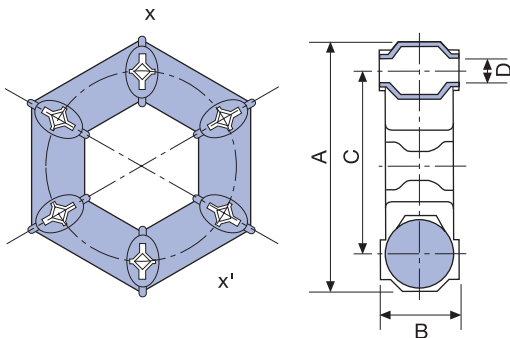

Type	A (mm)	B (mm)	D (mm)	C installed (mm)	C free (mm)	R.P.M. max.	Code	Weight (kg)	Nominal torque (mkg)
Flector 4MKG	91	28	8	65	75	6000	160201	0,227	4
Flector 9MKG	117	32	10	85	96	5000	160202	0,334	9
Flector 16MKG	142	46	12	100	110	4500	160203	0,839	16
Flector 25MKG	181	51	14	132	146	3500	160204	1,002	25
Flector 35MKG	202	54	18	150	170	3000	160205	1,412	35
Flector 50MKG	232	62	20	170	195	2800	160206	2,32	50
Flector 70MKG	263	68	20	190	216	2400	160207	3,309	70



AMC MECANOCAUCHO® TYPE DP

Type	Code	Force kg	A (mm)	B (mm)	C (mm)	D (mm)	E (mm)	F (mm)	G (mm)	H (mm)	Weight (kg)
ELEMENT DP-2	160241	174	84	52	M-12	30	35	84,5	50	3	0,75
ELEMENT DP-4	160242	300	120	75	M-16	44	49	120	75	5	1,777
ELEMENT DP-6	160243	1000	220	137	M-24	80	80	20	133	10	-
HOOD DP-2	160251	174	84	52	M-12	30	35	84,5	50	3	0,416
HOOD DP-4	160252	300	120	75	M-16	44	49	120	75	5	1,461
HOOD DP-6	160253	1000	220	137	M-24	80	80	20	133	10	-
BUSHING DP-2	160261	174	84	52	M-12	30	35	84,5	50	3	-
BUSHING DP-4	160262	300	120	75	M-16	44	49	120	75	5	0,249
BUSHING DP-6	160263	1000	220	137	M-24	80	80	20	133	10	-

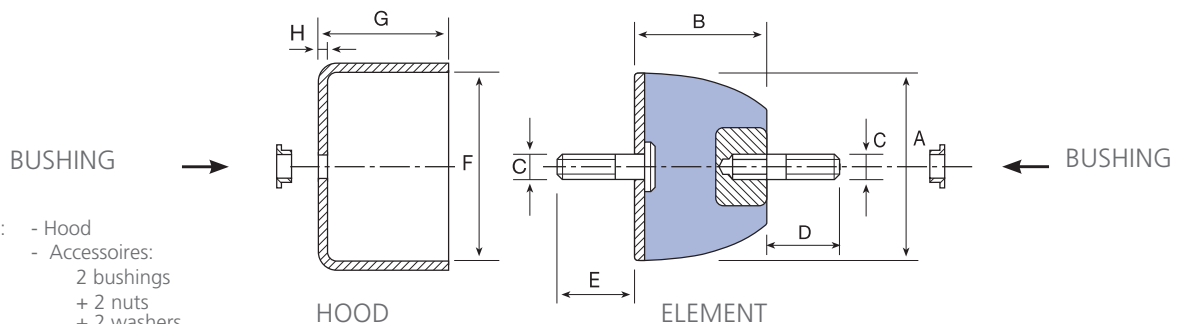

- * OPTIONS:
- Hood
 - Accessoires:
 - 2 bushings
 - + 2 nuts
 - + 2 washers

RUBBER BLOCKS & MATS AMC MECANOCAUCHO®



There are different mats, in different sizes, rubber grades and hardnesses. The most classic use is for damping high frequency vibrations without the need for any anchoring.

The user cuts them to the relevant size and can apply them using an adhesive, or simply by placing them on the base of the machine. In cases where contact with oils is foreseen, this should be indicated on the order.

The mat will be more or less elastic or anti-skid, depending on the different models.



AMC MECANOCAUCHO® TYPE T

Type	Code	Load (kg)	Deflection (mm)	Weight (kg)
RUBBER BLOCKS AND MATS Type T	141001	1000	4	0,687

Deflection curve on page 77

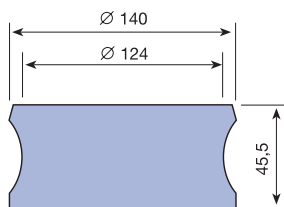

AMC MECANOCAUCHO® TYPE C

Type	Code	Load (kg)	Deflection (mm)	Weight (kg)
RUBBER BLOCKS AND MATS Type C	141002	3000	9	2,082

Deflection curve on page 77

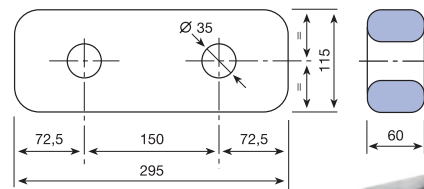

AMC MECANOCAUCHO® MAT 300x300

Type	Max. Load (Kg/cm ²)	Code	Weight (kg)	Thickness (mm)
RUBBER BLOCKS AND MATS 300 x 300	4	152001	0,521	8

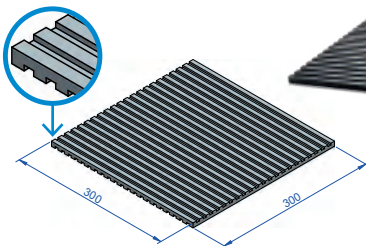

AMC MECANOCAUCHO® MAT 400x400

Type	Max. Load (Kg/cm ²)	Code	Weight (kg)	Thickness (mm)
RUBBER BLOCKS AND MATS 400 x 400	6	152003	1,471	12

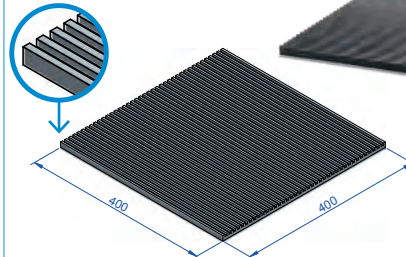

BLOCKS AMC MECANOCAUCHO®

These are square antivibration mounts which are ideal for installation without any type of attachment or anchoring.



	Type	A (mm)	B (mm)	Load kg MIN	Load kg MAX	Fig.	Code	Weight (kg)
	G-060	70	30	180	300	1	152005	0,16
	G-070	80	30	350	600	1	152006	0,218
	G-090	100	40	200	500	1	152008	0,359
	G-110	110	30	1600	3000	1	152009	0,4
	G-080	80	50	200	500	2	152007	0,313

AMC MECANOCAUCHO® BOBBINS

DESCRIPTION

The AMC MECANOCAUCHO® Bobbins are devices for making elastic anchorings or fixings. They can be used in a wide variety of applications, particularly for elastic suspensions and antivibration isolation of machines and different mechanical organs.

They are made of a block of rubber with two parallel metal parts at the end which enable it to be fixed either by screws in the "C" model or with nuts in the "A" model or a combination of both in the "B" model.

The rubber block may be cylindrical in cases requiring greater load capacity or as a diabolo when greater elasticity is required in all directions.

OPERATION AND ASSEMBLY

Its elasticity is much greater in all the directions parallel to the armatures than in the perpendicular direction. The rubber works based on compression or shear depending on the direction it is placed at installation time. This direction is made according to the use and the objective.

It is therefore installed with nuts or screws depending on the model chosen, with one part attached to the fixed chassis and the other to the machine to be suspended.

TECHNICAL CHARACTERISTICS

Depending on the size of the rubber block, the AMC MECANOCAUCHO® bobbing has more or less elasticity, which is greater particularly in all directions perpendicular to its axis (shear).

The AMC MECANOCAUCHO® bobbing thus makes it possible to make joints which permit major relative movements, up to several millimetres (in the case of heat expansion, chassis deformations, etc.).

The AMC MECANOCAUCHO® bobbing serves very well for the vibration isolation of machines where the vibrations are perpendicular to their axis, unless these stresses are too much when applied in this direction.

ADVANTAGES

- Easy to install.
- High elasticity (particularly transversal).
- Economical.

APPLICATIONS

The AMC MECANOCAUCHO® bobbins are particularly suitable for installation on small motor-pumps, motor-ventilators, driers, sieves, compactors, washing machines, electrical motors, on-board control panels, measuring apparatuses, control cabinets, microphones, fluorescent tubes, etc.



AMC MECANOCAUCHO® BOBBINS TYPE A

OPERATION AND ASSEMBLY

Their elasticity is much greater in all the directions parallel to the armatures than in the perpendicular direction. The rubber works based on compression or shear depending on the direction it is placed in at installation time. This direction is made according to the use and the objective.

It is therefore installed with nuts or screws depending on the model chosen, with one part attached to the fixed chassis and the other to the machine to be suspended.

APPLICATIONS

The AMC MECANOCAUCHO® bobbins are particularly suitable for installation on small motor-pumps, motor-ventilators, driers, sieves, compactors, washing machines, electrical motors, on-board control panels, measuring apparatuses, control cabinets, microphones, fluorescent tubes, etc.

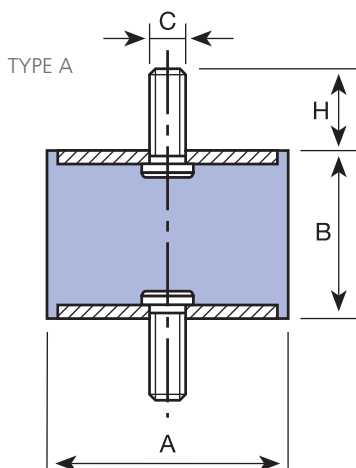

Type	Code	A (mm)	B (mm)	C (mm)	H (mm)	Weight (kg)	Compression load max. (dan)	Compression deflect. (mm)	Shear load max. (dan)	Shear deflect. (mm)
BOBBINS TYPE A 12-25	120001	12,5	10	M-5	10	0,006	12	2	1,5	1,5
	120002	12,5	15	M-5	10	0,007	10	3	1,5	2
	120003	12,5	20	M-5	10	0,008	8	3,5	1,5	4
	120011	16	10	M-5	12	0,01	20	1,5	2,5	1,5
	120012	16	15	M-5	12	0,011	20	3	2,5	2
	120013	16	20	M-5	12	0,012	15	4	2,5	4
	120014	16	25	M-5	12	0,013	15	5	2	5
	120021	20	8,5	M-6	16,5	0,016	40	1,5	5	1
	120022	20	15	M-6	16,5	0,018	35	4	5	2,5
	120023	20	20	M-6	16,5	0,019	30	5	5	3,5
	120024	20	25	M-6	16,5	0,02	30	5,5	4,5	4,5
	120025	20	30	M-6	16,5	0,022	25	7	4,5	4,5
	120171	25,5	10	M-6	18	0,032	80	2	8	1,5
	120172	25,5	15	M-6	18	0,032	60	3,5	8	2,5
	120173	25,5	20	M-6	18	0,039	55	4,5	8	3,5
	120174	25,5	25	M-6	18	0,041	50	6	8	4,5
120175	25,5	30	M-6	18	0,043	50	8	8	6	
120026	25,5	10	M-8	20	0,034	80	2	8	1,5	
120031	25,5	15	M-8	20	0,04	60	3,5	8	2,5	
120032	25,5	19	M-8	20	0,04	55	4,5	8	3,5	
120033	25,5	22	M-8	20	0,042	50	5,5	8	4	
120034	25,5	25	M-8	20	0,043	50	6	8	4,5	
120035	25,5	30	M-8	20	0,046	50	8	8	6	
120036	25,5	40	M-8	20	0,053	50	10	10	6	
BOBBINS TYPE A 30-50	120041	30	15	M-8	20	0,049	90	3	11	2,5
	120042	30	22	M-8	20	0,053	80	5	11	4
	120186	30	25	M-8	20	0,056	75	6,5	11	5
	120043	30	30	M-8	20	0,059	70	8	11	6
	120044	30	40	M-8	20	0,066	60	9	11	7,7
	120193	40	20	M-8	20	0,086	160	5	20	3
	120194	40	25	M-8	20	0,1	150	6	20	3,5
	120195	40	28	M-8	20	0,106	150	6	20	5,5
	120196	40	30	M-8	20	0,113	150	6	30	5,5
	120197	40	35	M-8	20	0,117	120	8	20	6,5
	120198	40	40	M-8	20	0,123	120	10	20	7,5
	120199	40	45	M-8	20	0,134	120	11	20	9
	120051	40	20	M-10	25	0,1	160	5	20	3
	120191	40	25	M-10	25	0,104	150	6	20	3,5
	120052	40	28	M-10	25	0,111	150	6	20	5,5
	120192	40	30	M-10	25	0,117	150	6	30	5,5
	120053	40	35	M-10	25	0,121	120	8	20	6,5
	120054	40	40	M-10	25	0,128	120	10	20	7,5
	120055	40	45	M-10	25	0,137	120	11	20	9
	120201	50	20	M-10	25	0,128	300	5	25	3,5
120061	50	25	M-10	25	0,132	300	6	25	4,5	
120202	50	30	M-10	25	0,148	275	7	25	6,5	
120062	50	35	M-10	25	0,153	250	8	25	7	
120203	50	40	M-10	25	0,169	210	10	25	8	
120063	50	45	M-10	25	0,179	190	11	25	9	
120204	50	50	M-10	25	0,199	170	11	25	10,5	
120064	50	60	M-10	25	0,21	150	11	25	12	
BOBBINS TYPE A 60-95	120071	60	25	M-10	25	0,207	400	6	30	4,5
	120072	60	36	M-10	25	0,241	300	9	30	7
	120073	60	45	M-10	25	0,269	250	11	30	9
	120074	60	60	M-10	25	0,315	200	12	30	10
	120081	70	35	M-10	25	0,322	450	8	35	6,5
	120082	70	50	M-10	25	0,38	350	11	35	11
	120083	70	60	M-10	25	0,423	300	12	35	13
	120084	70	70	M-10	25	0,485	300	14	35	15
	120091	75	25	M-12	30	0,32	650	7	37	5
	120092	75	40	M-12	30	0,402	500	9	37	7
	120093	75	45	M-12	30	0,423	500	10	37	9
	120094	75	55	M-12	30	0,468	450	11	37	11
	120101	80	30	M-14	35	0,503	950	7	40	5
	120102	80	40	M-14	35	0,561	600	9	40	7
120103	80	50	M-14	35	0,606	550	10	40	8	
120104	80	55	M-14	35	0,571	550	11	40	9	
120105	80	70	M-14	35	0,71	500	13	40	15	
120106	80	75	M-14	35	0,737	450	14	40	16	
120111	95	40	M-16	45	0,803	1200	8	60	7	
120112	95	55	M-16	45	0,932	1000	11	60	8	
120113	95	60	M-16	45	0,971	800	12	60	10	
120114	95	75	M-16	45	1,148	700	13	60	14	
BOBBINS TYPE A 105-150	120121	105	50	M-16	45	1	1200	9	80	9
	120122	105	75	M-16	45	1,283	1000	13	80	14
	120123	105	100	M-16	45	1,493	800	16	80	16
	120131	120	50	M-16	45	1,153	1500	9	100	9
	120132	120	75	M-16	45	1,568	1200	13	100	14
	120133	120	100	M-16	45	1,903	1000	16	100	16
	120142	130	50	M-16	45	1,658	1600	9	120	9
	120143	130	75	M-16	45	2,105	1450	13	120	14
	120144	130	100	M-16	45	2,492	1200	16	120	16
	120151	150	50	M-20	50	2,268	1800	9	140	9
120152	150	75	M-20	50	2,808	1650	13	140	14	
120153	150	100	M-20	50	3,356	1400	16	140	16	

AMC MECANOCAUCHO® BOBBINS TYPE B

OPERATION AND INSTALLATION

Their elasticity is much greater in all the directions parallel to the armatures than in the perpendicular direction. The rubber works based on compression or shear depending on the direction it is placed in at installation time. This direction is made according to the use and the objective.

It is therefore installed with nuts or screws depending on the model chosen, with one part attached to the fixed chassis and the other to the machine to be suspended.

APPLICATIONS

The AMC MECANOCAUCHO® bobbins are particularly suitable for installation on small motor-pumps, motor-ventilators, driers, sieves, compactors, washing machines, electrical motors, on-board control panels, measuring apparatuses, control cabinets, microphones, fluorescent tubes, etc.



TYPE B

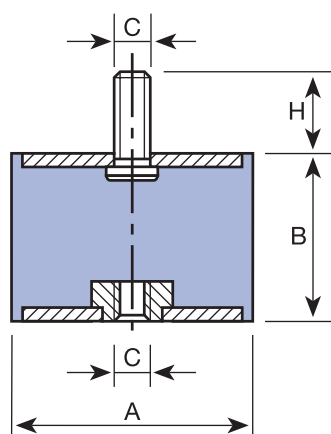

Type	Code	A (mm)	B (mm)	C (mm)	H (mm)	Weight (kg)	Compression load max. (dan)	Compression deflect. (mm)	Shear load max. (dan)	Shear deflect. (mm)
BOBBINS TYPE B 12-25	121001	12,5	10	M-5	10	0,005	12	2	1,5	1,5
	121002	12,5	15	M-5	10	0,006	10	3	1,5	2
	121003	12,5	20	M-5	10	0,007	8	3,5	1,5	4
	121011	16	10	M-5	12	0,008	20	1,5	2,5	1,5
	121012	16	15	M-5	12	0,01	20	3	2,5	2
	121013	16	20	M-5	12	0,011	15	4	2,5	4
	121014	16	25	M-5	12	0,012	15	5	2	5
	121022	20	15	M-6	16,5	0,017	35	4	5	2,5
	121023	20	20	M-6	16,5	0,018	30	5	5	3,5
	121024	20	25	M-6	16,5	0,02	30	5,5	4,5	4,5
	121025	20	30	M-6	16,5	0,021	25	7	4,5	4,5
	121172	25,5	15	M-6	18	0,033	60	3,5	8	2,5
	121173	25,5	20	M-6	18	0,034	55	4,5	8	3,5
	121174	25,5	25	M-6	18	0,037	50	6	8	4,5
121175	25,5	30	M-6	18	0,038	50	8	8	6	
121031	25,5	15	M-8	20	0,036	60	3,5	8	2,5	
121032	25,5	19	M-8	20	0,037	55	4,5	8	3,5	
121033	25,5	22	M-8	20	0,038	50	5,5	8	4	
121034	25,5	25	M-8	20	0,039	50	6	8	4,5	
121035	25,5	30	M-8	20	0,041	50	8	8	6	
121036	25,5	40	M-8	20	0,046	50	10	10	6	
BOBBINS TYPE B 30-40	121041	30	15	M-8	20	0,047	90	3	11	2,5
	121042	30	22	M-8	20	0,049	80	5	11	4
	121186	30	25	M-8	20	0,053	75	6,5	11	5
	121043	30	30	M-8	20	0,056	70	8	11	6
	121044	30	40	M-8	20	0,062	60	9	11	7,5
	121193	40	20	M-8	20	0,078	160	5	20	3
	121194	40	25	M-8	20	0,095	150	6	20	3,5
	121195	40	28	M-8	20	0,098	150	6	20	5,5
	121196	40	30	M-8	20	0,101	150	6	30	5,5
	121197	40	35	M-8	20	0,102	120	8	20	6,5
	121198	40	40	M-8	20	0,105	120	10	20	7,5
	121199	40	45	M-8	20	0,12	120	11	20	9
	121051	40	20	M-10	25	0,09	160	5	20	3
	121191	40	25	M-10	25	0,099	150	6	20	3,5
121052	40	28	M-10	25	0,103	150	6	20	5,5	
121192	40	30	M-10	25	0,103	150	6	30	5,5	
121053	40	35	M-10	25	0,105	120	8	20	6,5	
121054	40	40	M-10	25	0,109	120	10	20	7,5	
121055	40	45	M-10	25	0,125	120	11	20	9	
BOBBINS TYPE B 50-75	121201	50	20	M-10	25	0,124	300	5	25	3,5
	121061	50	25	M-10	25	0,128	300	6	25	4,5
	121202	50	30	M-10	25	0,141	275	7	25	6,5
	121062	50	35	M-10	25	0,151	250	8	25	7
	121203	50	40	M-10	25	0,162	210	10	25	8
	121063	50	45	M-10	25	0,173	190	11	25	9
	121204	50	50	M-10	25	0,192	170	11	25	10,5
	121064	50	60	M-10	25	0,202	150	11	25	12
	121071	60	25	M-10	25	0,204	400	6	30	4,5
	121072	60	36	M-10	25	0,238	300	9	30	7
	121073	60	45	M-10	25	0,264	250	11	30	9
	121074	60	60	M-10	25	0,311	200	12	30	10
	121081	70	35	M-10	25	0,311	450	8	35	6,5
	121082	70	50	M-10	25	0,371	350	11	35	11
121083	70	60	M-10	25	0,416	300	12	35	13	
121084	70	70	M-10	25	0,479	300	14	35	15	
121091	75	25	M-12	30	0,301	650	7	37	5	
121092	75	40	M-12	30	0,384	500	9	37	7	
121093	75	45	M-12	30	0,411	500	10	37	9	
121094	75	55	M-12	30	0,455	450	11	37	11	
BOBBINS TYPE B 80-150	121101	80	30	M-14	35	0,445	950	7	40	5
	121102	80	40	M-14	35	0,505	600	9	40	7
	121103	80	50	M-14	35	0,521	550	10	40	8
	121104	80	55	M-14	35	0,544	550	11	40	9
	121105	80	70	M-14	35	0,648	500	13	40	15
	121106	80	75	M-14	35	0,687	450	14	40	16
	121111	95	40	M-16	45	0,769	1200	8	60	7
	121112	95	55	M-16	45	0,88	1000	11	60	8
	121113	95	60	M-16	45	0,888	800	12	60	10
	121114	95	75	M-16	45	1,087	700	13	60	14
	121121	105	50	M-16	45	0,927	1200	9	80	9
	121122	105	75	M-16	45	1,208	1000	13	80	14
	121123	105	100	M-16	45	1,422	800	16	80	16
	121131	120	50	M-16	45	1,078	1500	9	100	9
121132	120	75	M-16	45	1,407	1200	13	100	14	
121133	120	100	M-16	45	1,834	1000	16	100	16	
121142	130	50	M-16	45	1,591	1600	9	120	9	
121143	130	75	M-16	45	2,039	1450	13	120	14	
121144	130	100	M-16	45	2,426	1200	16	120	16	
121151	150	50	M-20	50	3,301	1800	9	140	9	
121152	150	75	M-20	50	4,001	1650	13	140	14	
121153	150	100	M-20	50	-	1400	16	140	16	

AMC MECANOCAUCHO® BOBBINS TYPE C

OPERATION AND INSTALLATION

Their elasticity is much greater in all the directions parallel to the armatures than in the perpendicular direction. The rubber works based on compression or shear depending on the direction it is placed in at installation time. This direction is made according to the use and the objective.

It is therefore installed with nuts or screws depending on the model chosen, with one part attached to the fixed chassis and the other to the machine to be suspended.

APPLICATIONS

The AMC MECANOCAUCHO® bobbins are particularly suitable for installation on small motor-pumps, motor-ventilators, driers, sieves, compactors, washing machines, electrical motors, on-board control panels, measuring apparatuses, control cabinets, microphones, fluorescent tubes, etc.



TYPE C

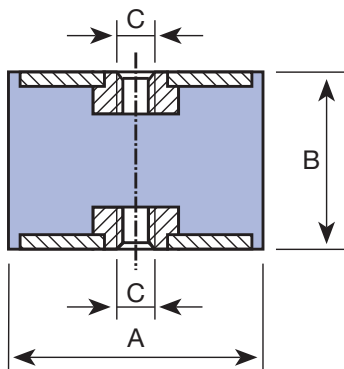

Type	Code	A (mm)	B (mm)	C (mm)	Weight (kg)	Compression load max. (dan)	Compression deflect. (mm)	Shear load max. (dan)	Shear deflect. (mm)
BOBBINS TYPE C 12-30	122003	12,5	20	M-5	0,007	8	3,5	1,5	4
	122013	16	20	M-5	0,01	15	4	2,5	4
	122014	16	25	M-5	0,012	15	5	2	5
	122023	20	20	M-6	0,017	30	5	5	3,5
	122024	20	25	M-6	0,018	30	5,5	4,5	4,5
	122025	20	30	M-6	0,019	25	7	4,5	4,5
	122173	25,5	20	M-6	0,03	55	4,5	8	3,5
	122174	25,5	25	M-6	0,035	50	6	8	4,5
	122175	25,5	30	M-6	0,036	50	8	8	6
	122032	25,5	19	M-8	0,031	55	4,5	8	3,5
	122033	25,5	22	M-8	0,038	50	5,5	8	4
	122034	25,5	25	M-8	0,037	50	6	8	4,5
	122035	25,5	30	M-8	0,038	50	8	8	6
	122036	25,5	40	M-8	0,044	50	10	10	6
122042	30	22	M-8	0,045	80	5	11	4	
122186	30	25	M-8	0,048	75	6,5	11	5	
122043	30	30	M-8	0,052	70	8	11	6	
122044	30	40	M-8	0,061	60	9	11	7,5	
BOBBINS TYPE C 40-60	122194	40	25	M-8	0,089	150	6	20	3,5
	122195	40	28	M-8	0,097	150	6	20	5,5
	122196	40	30	M-8	0,097	150	6	30	5,5
	122197	40	35	M-8	0,099	120	8	20	6,5
	122198	40	40	M-8	0,106	120	10	20	7,5
	122199	40	45	M-8	0,111	120	11	20	9
	122052	40	28	M-10	0,094	150	6	20	5,5
	122192	40	30	M-10	0,099	150	6	30	5,5
	122053	40	35	M-10	0,102	120	8	20	6,5
	122054	40	40	M-10	0,109	120	10	20	7,5
	122055	40	45	M-10	0,114	120	11	20	9
	122061	50	25	M-10	0,117	300	6	25	4,5
	122202	50	30	M-10	0,134	275	7	25	6,5
	122062	50	35	M-10	0,146	250	8	25	7
	122203	50	40	M-10	0,161	210	10	25	8
	122063	50	45	M-10	0,171	190	11	25	9
	122204	50	50	M-10	0,185	170	11	25	10,5
	122064	50	60	M-10	0,199	150	11	25	12
122071	60	25	M-10	0,194	400	6	30	4,5	
122072	60	36	M-10	0,234	300	9	30	7	
122073	60	45	M-10	0,255	250	11	30	9	
122074	60	60	M-10	0,304	200	12	30	10	
122081	70	35	M-10	0,307	450	8	35	6,5	
122082	70	50	M-10	0,376	350	11	35	11	
122083	70	60	M-10	0,41	300	12	35	13	
122084	70	70	M-10	0,469	300	14	35	15	
122092	75	40	M-12	0,351	500	9	37	7	
122093	75	45	M-12	0,395	500	10	37	9	
122094	75	55	M-12	0,436	450	11	37	11	
122101	80	30	M-14	0,391	950	7	40	5	
122102	80	40	M-14	0,449	600	9	40	7	
122103	80	50	M-14	0,492	550	10	40	8	
122104	80	55	M-14	0,516	550	11	40	9	
122105	80	70	M-14	0,602	500	13	40	15	
122106	80	75	M-14	0,63	450	14	40	16	
122111	95	40	M-16	0,714	1.200	8	60	7	
122112	95	55	M-16	0,851	1.000	11	60	8	
122113	95	60	M-16	0,88	800	12	60	10	
122114	95	75	M-16	1,026	700	13	60	14	
122122	105	50	M-16	0,714	1.200	9	80	9	
122123	105	75	M-16	1,158	1.000	13	80	14	
122124	105	100	M-16	1,405	800	16	80	16	
122131	120	50	M-16	1,108	1.500	9	100	9	
122132	120	75	M-16	1,366	1.200	13	100	14	
122133	120	100	M-16	1,702	1.000	16	100	16	
122142	130	50	M-16	2,125	1.600	9	120	9	
122143	130	75	M-16	1,962	1.450	13	120	14	
122144	130	100	M-16	2,356	1.200	16	120	16	
122151	150	50	M-20	2,024	1.800	9	140	9	
122152	150	75	M-20	2,558	1.650	13	140	14	
122153	150	100	M-20	2,996	1.400	16	140	16	

SIMPLE BUFFERS AMC MECANOCAUCHO® TYPE D

APPLICATIONS

As buffers: In any case for limiting a flexible element.

- End of stroke of spring or damper.
- End of stroke of cranes and hoists.
- Setting of fragile material in packings.

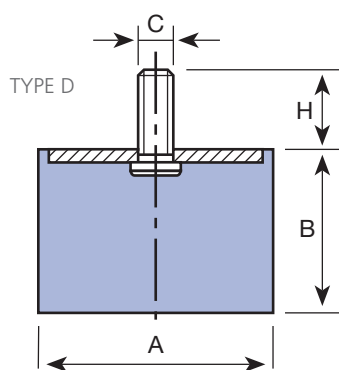
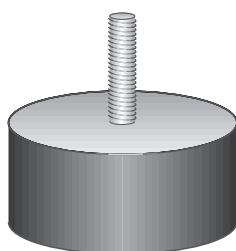

Type	Code	A (mm)	B (mm)	C (mm)	H (mm)	Weight (kg)	Compression load max. (dan)	Compression deflect. (mm)
SIMPLE BUFFERS AMC 12-25	110001	12,5	10	M-5	10	0,004	12	2
	110002	12,5	15	M-5	10	0,004	10	3
	110003	12,5	20	M-5	10	0,005	8	3,5
	110004	16	10	M-5	12	0,006	20	1,5
	110005	16	15	M-5	12	0,008	20	3
	110006	16	20	M-5	12	0,008	15	4
	110007	16	25	M-5	12	0,009	15	5
	110008	20	8,5	M-6	16,5	0,009	40	1,5
	110009	20	15	M-6	16,5	0,012	35	4
	110010	20	20	M-6	16,5	0,012	30	5
	110011	20	25	M-6	16,5	0,015	30	5,5
	110012	20	30	M-6	16,5	0,017	25	7
	110091	25,5	10	M-6	18	0,02	80	2
	110092	25,5	15	M-6	18	0,021	60	3,5
	110093	25,5	20	M-6	18	0,022	55	4,5
	110094	25,5	25	M-6	18	0,025	50	6
	110095	25,5	30	M-6	18	0,028	50	8
	110013	25,5	10	M-8	20	0,022	80	2
	110014	25,5	15	M-8	20	0,024	60	3,5
110015	25,5	19	M-8	20	0,025	55	4,5	
110016	25,5	22	M-8	20	0,027	50	5,5	
110017	25,5	25	M-8	20	0,028	50	6	
110018	25,5	30	M-8	20	0,032	50	8	
110019	25,5	40	M-8	20	0,036	50	10	
SIMPLE BUFFERS AMC 30-50	110020	30	15	M-8	20	0,03	90	3
	110021	30	22	M-8	20	0,034	80	5
	110101	30	25	M-8	20	0,037	75	6,5
	110022	30	30	M-8	20	0,041	70	8
	110023	30	40	M-8	20	0,05	60	9
	110112	40	20	M-8	20	0,06	160	5
	110113	40	25	M-8	20	0,068	150	6
	110114	40	28	M-8	20	0,072	150	6
	110115	40	30	M-8	20	0,08	150	6
	110116	40	35	M-8	20	0,082	120	8
	110117	40	40	M-8	20	0,087	120	10
	110118	40	45	M-8	20	0,089	120	11
	110024	40	20	M-10	25	0,064	160	5
	110110	40	25	M-10	25	0,07	150	6
	110025	40	28	M-10	25	0,076	150	6
	110111	40	30	M-10	25	0,07	150	6
	110026	40	35	M-10	25	0,086	120	8
	110027	40	40	M-10	25	0,092	120	10
	110028	40	45	M-10	25	0,094	120	11
	110121	50	20	M-10	25	0,09	300	5
110029	50	25	M-10	25	0,093	300	6	
110122	50	30	M-10	25	0,104	275	7	
110030	50	35	M-10	25	0,114	250	8	
110123	50	40	M-10	25	0,125	210	10	
110031	50	45	M-10	25	0,138	190	11	
110124	50	50	M-10	25	0,144	170	11	
110032	50	60	M-10	25	0,17	150	11	
SIMPLE BUFFERS AMC 60-95	110033	60	25	M-10	25	0,145	400	6
	110034	60	36	M-10	25	0,177	300	9
	110035	60	45	M-10	25	0,206	250	11
	110036	60	60	M-10	25	0,251	200	12
	110037	70	35	M-10	25	0,236	450	8
	110038	70	50	M-10	25	0,294	350	11
	110039	70	60	M-10	25	0,336	300	12
	110040	70	70	M-10	25	0,397	300	14
	110041	75	25	M-12	30	0,222	650	7
	110042	75	40	M-12	30	0,302	500	9
	110043	75	45	M-12	30	0,323	500	10
	110044	75	55	M-12	30	0,373	450	11
	110045	80	30	M-14	35	0,341	950	7
	110046	80	40	M-14	35	0,395	600	9
	110047	80	50	M-14	35	0,415	550	10
	110048	80	55	M-14	35	0,458	550	11
	110049	80	70	M-14	35	0,547	500	13
110050	80	75	M-14	35	0,579	450	14	
110051	95	40	M-16	45	0,568	1200	8	
110052	95	55	M-16	45	0,689	1000	11	
110053	95	60	M-16	45	0,743	800	12	
110054	95	75	M-16	45	0,892	700	13	
SIMPLE BUFFERS AMC 105-150	110055	105	50	M-16	45	0,754	1200	9
	110056	105	75	M-16	45	1,262	1000	13
	110057	105	100	M-16	45	1,514	800	16
	110058	120	50	M-16	45	0,917	1500	9
	110059	120	75	M-16	45	1,252	1200	13
	110060	120	100	M-16	45	1,579	1000	16
	110062	130	50	M-16	45	1,257	1600	9
	110063	130	75	M-16	45	1,647	1450	13
	110064	130	100	M-16	45	2,035	1200	16
	110065	150	50	M-20	50	1,678	1800	9
	110066	150	75	M-20	50	2,202	1650	13
	110067	150	100	M-20	50	2,774	1400	16

SIMPLE BUFFERS

AMC MECANOCAUCHO®

TYPE E

APPLICATIONS

As buffers: In any case for limiting a flexible element.

- End of stroke of spring or damper.
- End of stroke of cranes and hoists.
- Setting of fragile material in packings.

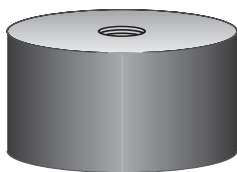

TYPE E

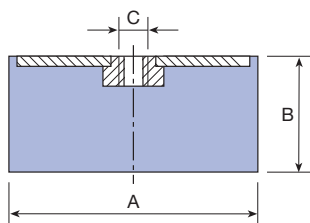

Type	Code	A (mm)	B (mm)	C (mm)	Weight (kg)	Compression load max. (dan)	Compression deflect. (mm)
SIMPLE BUFFERS TYPE E 12-25	111001	12,5	10	M-5	0,004	12	2
	111002	12,5	15	M-5	0,004	10	3
	111003	12,5	20	M-5	0,004	8	3,5
	111004	16	10	M-5	0,005	20	1,5
	111005	16	15	M-5	0,006	20	3
	111006	16	20	M-5	0,007	15	4
	111007	16	25	M-5	0,008	15	5
	111008	20	8,5	M-6	0,008	40	1,5
	111009	20	15	M-6	0,008	35	4
	111010	20	20	M-6	0,011	30	5
	111011	20	25	M-6	0,012	30	5,5
	111012	20	30	M-6	0,015	25	7
	111091	25,5	10	M-6	0,015	80	2
	111092	25,5	15	M-6	0,016	60	3,5
	111093	25,5	20	M-6	0,021	55	4,5
	111094	25,5	25	M-6	0,023	50	6
	111095	25,5	30	M-6	0,026	50	8
	111013	25,5	10	M-8	0,017	80	2
	111014	25,5	15	M-8	0,019	60	3,5
111015	25,5	19	M-8	0,021	55	4,5	
111016	25,5	22	M-8	0,024	50	5,5	
111017	25,5	25	M-8	0,025	50	6	
111018	25,5	30	M-8	0,029	50	8	
111019	25,5	40	M-8	0,033	50	10	
SIMPLE BUFFERS TYPE E 30-50	111020	30	15	M-8	0,025	90	3
	111021	30	22	M-8	0,028	80	5
	111101	30	25	M-8	0,034	75	6,5
	111022	30	30	M-8	0,038	70	8
	111023	30	40	M-8	0,045	60	9
	111112	40	20	M-8	0,051	160	5
	111113	40	25	M-8	0,056	150	6
	111114	40	28	M-8	0,061	150	6
	111115	40	30	M-8	0,063	150	6
	111116	40	35	M-8	0,071	120	8
	111117	40	40	M-8	0,071	120	10
	111118	40	45	M-8	0,085	120	11
	111024	40	20	M-10	0,054	160	5
	111110	40	25	M-10	0,059	150	6
	111025	40	28	M-10	0,065	150	6
	111111	40	30	M-10	0,066	150	6
	111026	40	35	M-10	0,075	120	8
	111027	40	40	M-10	0,081	120	10
	111028	40	45	M-10	0,089	120	11
	111121	50	20	M-10	0,084	300	5
111029	50	25	M-10	0,088	300	6	
111122	50	30	M-10	0,101	275	7	
111030	50	35	M-10	0,111	250	8	
111123	50	40	M-10	0,124	210	10	
111031	50	45	M-10	0,134	190	11	
111124	50	50	M-10	0,151	170	11	
111032	50	60	M-10	0,166	150	11	
SIMPLE BUFFERS TYPE E 60-95	111033	60	25	M-10	0,138	400	6
	111034	60	36	M-10	0,171	300	9
	111035	60	45	M-10	0,197	250	11
	111036	60	60	M-10	0,246	200	12
	111037	70	35	M-10	0,225	450	8
	111038	70	50	M-10	0,287	350	11
	111039	70	60	M-10	0,327	300	12
	111040	70	70	M-10	0,396	300	14
	111041	75	25	M-12	0,201	650	7
	111042	75	40	M-12	0,277	500	9
	111043	75	45	M-12	0,3	500	10
	111044	75	55	M-12	0,348	450	11
	111045	80	30	M-14	0,283	950	7
	111046	80	40	M-14	0,335	600	9
	111047	80	50	M-14	0,382	550	10
	111048	80	55	M-14	0,411	550	11
	111049	80	70	M-14	0,495	500	13
111050	80	75	M-14	0,515	450	14	
111051	95	40	M-16	0,521	1200	8	
111052	95	55	M-16	0,642	1000	11	
111053	95	60	M-16	0,691	800	12	
111054	95	75	M-16	0,84	700	13	
SIMPLE BUFFERS TYPE E 105-150	111055	105	50	M-16	0,71	1200	9
	111056	105	75	M-16	0,956	1000	13
	111057	105	100	M-16	1,19	800	16
	111058	120	50	M-16	0,856	1500	9
	111059	120	75	M-16	1,203	1200	13
	111060	120	100	M-16	1,52	1000	16
	111062	130	50	M-16	1,19	1600	9
	111063	130	75	M-16	1,57	1450	13
111064	130	100	M-16	1,958	1200	16	
111065	150	50	M-20	1,537	1800	9	
111066	150	75	M-20	2,557	1650	13	
111067	150	100	M-20	2,639	1400	16	

STANDARD STAINLESS STEEL AMC MECANOCAUCHO® BOBBINS



OPERATION AND ASSEMBLY

Their elasticity is much greater in all the directions parallel to the armatures than in the perpendicular direction. The rubber works based on compression or shear depending on the direction it is placed in at installation time. This direction is made according to the use and the objective.

It is therefore installed with nuts or screws depending on the model chosen, with one part attached to the fixed chassis and the other to

the machine to be suspended.

APPLICATIONS

The AMC MECANOCAUCHO® bobbins are particularly suitable for installation on small motor-pumps, motor-ventilators, driers, sieves, compactors, washing machines, electrical motors, on-board control panels, measuring apparatuses, control cabinets, microphones, fluorescent tubes, etc.

Type	Code	A (mm)	B (mm)	C (mm)	H (mm)	Weight (kg)	Compression load max. (dan)	Compression deflect. (mm)	Shear load max. (dan)	Shear deflect. (mm)
BOBBINS TYPE A 12-25 STAINLESS STEEL	120301	20	20	M-6	18	0,019	30	5	5	3,5
	120302	20	25	M-6	18	-	30	5,5	4,5	4,5
	120303	25	25	M-6	18	-	55	4,5	8	3,5
	120304	25	30	M-6	18	-	50	8	8	6
	120305	30	20	M-8	23	0,055	80	5	11	4
	120306	30	30	M-8	23	-	70	8	11	6
	120307	40	30	M-8	23	0,092	150	6	30	5,5
	120308	40	40	M-10	28	0,131	120	10	20	7,5
	120309	50	25	M-10	28	-	300	6	25	4,5
	120310	50	35	M-10	28	-	250	8	25	7
	120311	50	45	M-10	28	-	190	11	25	9
	120312	60	35	M-10	28	-	300	9	30	7
	120313	60	45	M-10	28	0,255	250	11	30	9
	120314	60	60	M-10	28	0,304	200	12	30	10
	120315	70	45	M-12	37	0,376	350	11	35	11

Type	Code	A (mm)	B (mm)	C (mm)	Weight (kg)	Compression load max. (dan)	Compression deflect. (mm)	Shear load max. (dan)	Shear deflect. (mm)
BOBBINS TYPE C STAINLESS STEEL	120401	60	35	M-10	-	300	9	30	7
	120402	60	60	M-10	0,272	200	12	30	10
	120403	70	55	M-12	0,361	325	11,5	35	12
	120404	80	75	M-12	0,57	450	14	40	16
	120405	100	80	M-16	-	1000	13	80	14

AMC MECANOCAUCHO® DIABOLO MOUNTS



APPLICATIONS

The AMC MECANOCAUCHO® Diabolo mounts are particularly suitable for installation on small motor-pumps, motor-ventilators, driers, sieves, compactors, washing machines, electrical motors, on-board control panels, measuring apparatuses, control cabinets, micro-phones, fluorescent tubes, etc.

TYPE A		Type	A (mm)	B (mm)	D (mm)	H (mm)	Compression load max. (dan)	Compression defect. (mm)	Shear load max. (dan)	Shear defect. (mm)	Code	C (mm)	Weight (kg)
		F.000N	12	12	8	10	4	1,5	0,4	1,5	129001	M-5	0,006
F.00N	20	19	13,5	16,5	12	2,5	3	5	129002	M-6	0,017		
F.3	30	25	24	20	40	5	4	4,5	129003	M-8	0,08		
F.0N	40	28	19	25	30	5	2,5	4,5	129004	M-10	0,093		
F.9	40	30	26	25	45	3	4	4,5	129005	M-8	0,08		
F.7	44	42	25	25	50	6	9	6	129006	M-8	0,094		
F.1	60	44	24	20	40	5	7	5	129007	M-8	0,174		
F.2	60	44	34	20	75	5	12	6	129008	M-8	0,188		
F.2	60	44	34	25	75	5	12	6	129013	M-10	0,188		
F.4	60	60	50	25	150	8	30	10	129009	M-10	0,279		
F.8	60	36	37	25	100	7	20	8	129010	M-10	0,205		
F.5	80	70	70	35	300	9,5	55	9,8	129011	M-14	0,667		
F.6	95	76	80	45	400	9,5	70	8	129012	M-16	0,952		

TYPE B		Type	A (mm)	B (mm)	D (mm)	H (mm)	Compression load max. (dan)	Compression defect. (mm)	Shear load max. (dan)	Shear defect. (mm)	Code	C (mm)	Weight (kg)
		F.000N	12	12	8	10	4	1,5	0,4	1,5	129101	M-5	0,005
F.00N	20	19	13,5	16,5	12	2,5	3	5	129102	M-6	0,016		
F.3	30	25	24	20	40	5	4	4,5	129103	M-8	0,046		
F.0N	40	28	19	25	30	5	2,5	4,5	129104	M-10	0,084		
F.9	40	30	26	25	45	3	4	4,5	128006	M-8	0,072		
F.7	44	42	25	25	50	6	9	6	129105	M-8	0,074		
F.1	60	44	24	20	40	5	7	5	129106	M-8	0,09		
F.2	60	44	34	20	75	5	12	6	129107	M-8	0,167		
F.2	60	44	34	25	75	5	12	6	129108	M-8	0,183		
F.4	60	60	50	25	150	8	30	10	128010	M-10	-		
F.8	60	36	37	25	100	7	20	8	129109	M-10	0,271		
F.5	80	70	70	35	300	9,5	55	9,8	129110	M-10	0,202		
F.5	80	70	70	35	300	9,5	55	9,8	129111	M-14	0,616		
F.6	95	76	80	45	400	9,5	70	8	129112	M-16	0,94		

TYPE C		Type	A (mm)	B (mm)	D (mm)	Compression load max. dan	Compression defect. mm	Shear load max. dan	Shear defect. mm	Code	C (mm)	Weight (kg)
		F.00N	20	19	13,5	12	2,5	3	5	129202	M-6	0,015
F.3	30	25	24	40	5	4	4,5	129203	M-8	0,055		
F.0N	40	28	19	30	5	2,5	4,5	129204	M-10	0,074		
F.9	40	30	26	45	3	4	4,5	129213	M-8	0,058		
F.7	44	42	25	50	6	9	6	129205	M-8	0,069		
F.1	60	44	24	40	5	7	5	129206	M-8	0,082		
F.1	60	44	24	40	5	7	5	129207	M-8	0,164		
F.2	60	44	34	75	5	12	6	129208	M-8	0,174		
F.2	60	44	34	75	5	12	6	128002	M-10	0,198		
F.4	60	60	50	150	8	30	10	129209	M-10	0,257		
F.8	60	36	37	100	7	20	8	129210	M-10	0,187		
F.5	80	70	70	300	9,5	55	9,8	129211	M-14	0,551		
F.5	80	70	70	300	9,5	55	9,8	129211	M-14	0,551		
F.6	95	76	80	400	9,5	70	8	129212	M-16	0,897		

TRAPEZOIDAL MOUNTS AMC MECANOCAUCHO®



APPLICATIONS

Trapezoid mounts for ventilation boxes, small air-conditioning units, etc.

Type	B (mm)	C	D (mm)	A1 (mm)	A2 (mm)	Code	Load Min (kg)	Load Max (kg)
A-35-b	24	M8	24	30	40	131001	3	30
A-35	24	M8	24	30	40	131002	25	50
A-45-b	34	M8	24	40	50	131003	50	70
A-45	34	M8	24	40	50	131004	60	85
A-60	48	M12	Female	60	65	131005	85	150
A-130	72	M18	Female	130	140	131006	500	1.000

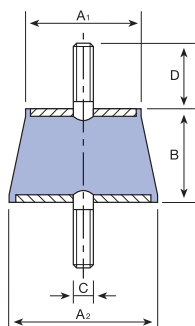

ANNULAR MOUNTS AMC MECANOCAUCHO®



APPLICATIONS

The AMC MECANOCAUCHO® Annular Mounts are comprised of a rubber ring joined by two metal parts with screws for fixation. Thanks to their design, these antivibration mounts may insulate low frequencies with low loads.

Type	A (mm)	B (mm)	C	D (mm)	E (mm)	G (mm)	Code	Load (kg)	Deflection (mm)
832	9,5	18	M4	14	14	8	130011	0,5	1,5
828	9,5	18	M4	14	14	8	130003	1,25	1,5
829	9,5	18	M4	14	14	8	130001	2,5	1
830	24	30	M8	29	24	20	130004	3,5	6
831	24	30	M8	29	24	20	130002	8	6

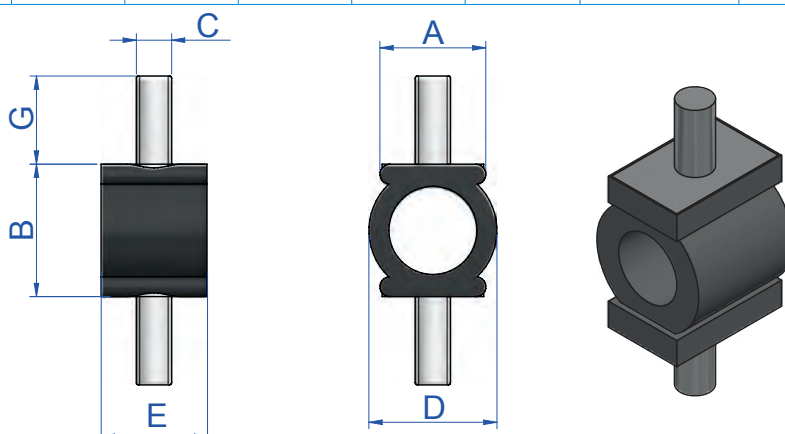

PROGRESSIVE BUFFERS AMC MECANOCAUCHO®



APPLICATIONS

As buffers: In any case for limiting a flexible element.

- End of stroke of spring or damper.
- End of stroke of cranes and hoists.
- Setting of fragile material in packings.



TYPE A		Type	Code	A (mm)	B (mm)	C	H (mm)	Load (kg)	Energy a 1 m/s Kg. M.	Dynamic Deflection (mm)
		T-25	115001	25	19	M8	20	100	0,3	8
		T-30	115002	30	30	M6	16	140	0,6	15
		T-40	113025	35	40	M10	25	180	2	20
		T-50	115003	50	50	M8	20	340	3	25
		T-50	115004	50	64	M8	35	370	4	32
		T-50	115005	50	58	M8	20	400	3,7	28
		T-70	115006	72	58	M12	30	550	5	26

TYPE C		Type	Code	A (mm)	B (mm)	C	Load (kg)	Energy a 1 m/s Kg. M.	Dynamic Deflection (mm)
		T-25	115008	25	19	M8	100	0,3	8
		T-30	115009	30	30	M6	140	0,6	15
		T-50	115010	50	50	M8	340	3	25
		T-50	115011	50	64	M8	370	4	32
		T-50	115012	50	58	M8	400	3,7	28
		T-70	115014	72	58	M12	550	5	26
		T-95	115015	95	80	M16	1100	12	37

TYPE A		Type	Code	A (mm)	B (mm)	C	H (mm)	Load (kg)	Energy a 1 m/s Kg. M.	Dynamic Deflection (mm)
		T-95	115007	95	80	M16	45	1100	12	37
		T - 85	116001	84	52	M12	35	1500	20	20
		T - 120	116002	120	75	M16	45	3000	34	22
T - 220	116003	220	137	M24	80	15000	250	40		

TYPE C		Type	Code	A (mm)	B (mm)	C	Load (kg)	Energy a 1 m/s Kg. M.	Dynamic Deflection (mm)
		T - 85	116011	84	52	M12	1500	20	20
		T - 120	116012	120	75	M16	3000	34	22
T - 220	116013	220	137	M24	15000	250	40		

DIABOLO BUFFERS AMC MECANOCAUCHO®



APPLICATIONS

As buffers: In any case for limiting a flexible element.

- End of stroke of spring or damper.
- End of stroke of cranes and hoists.
- Setting of fragile material in packings.

TYPE A							Type	Code	A (mm)	B (mm)	C (mm)	H (mm)	Weight (kg)	Static load max. daN	Dynamic load max. daN	Dynamic Deflection (mm)	Static Deflection (mm)
	F.3	114001	30	23	M-8	20	0,032	40	90	9	5						
F.7	114002	44	42	M-8	20	0,07	50	100	10	6							
F.1	114003	60	44	M-8	20	0,116	40	100	10	4							
F.2	114004	60	44	M-8	20	0,127	75	200	12	5,5							
F.4	114005	60	60	M-10	25	0,213	150	350	15	8							
F.8	114006	60	31	M-10	25	0,135	100	275	14	7							
F.5	114007	80	65	M-14	35	0,508	300	800	16	9,5							
F.6	114008	95	70	M-16	45	0,724	400	1000	18	9,5							

TYPE C							Type	Code	A (mm)	B (mm)	C (mm)	Weight (kg)	Static load max. daN	Dynamic load max. daN	Dynamic Deflection (mm)	Static Deflection (mm)
	F.3	114011	30	23	M-8	0,036	40	90	9	5						
F.7	114012	44	42	M-8	0,066	50	100	10	6							
F.1	114013	60	44	M-8	0,098	40	100	10	4							
F.2	114014	60	44	M-8	0,117	75	200	12	5,5							
F.4	114015	60	60	M-10	0,204	150	350	15	8							
F.8	114016	60	31	M-10	0,127	100	275	14	7							
F.5	114017	80	65	M-14	0,445	300	800	16	9,5							
F.6	114018	95	70	M-16	0,673	400	1000	18	9,5							

CYLINDRICAL BUFFERS AMC MECANOCAUCHC



APPLICATIONS

As buffers: In any case for limiting a flexible element.

- End of stroke of spring or damper.
- End of stroke of cranes and hoists.
- Setting of fragile material in packings.



							Type	Code	A (mm)	B (mm)	C (mm)	D (mm)	E (mm)	Load (kg)	Deflection (mm)	Weight (kg)	Energy (Nm)
	T - 150	117001	160	125	185	150	13,5	5000	50	4,172	1250						
T - 250	117002	250	208	315	250	14,5	40000	100	18	12500							

HEIGHT ADJUSTING SYSTEMS

The AMC Mecanocaucho® height adjusting systems can be used to retrofit current installations. Please take into consideration the following information:

It is recommendable to settle the mountings at least 48hours before the alignment of the engine installation, especially for close coupling tolerances.

The use of high performance glue between the bolt and the mounting is advisable in order to increase the security.

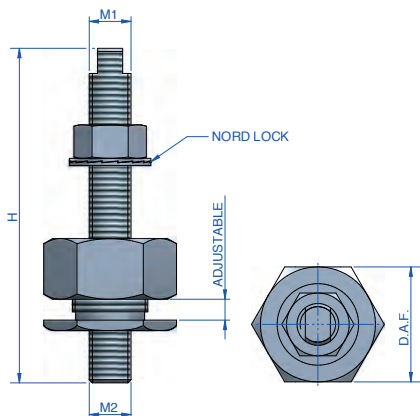

Hi-Sec

Type	Code	H (mm)	M1	M2	Adjustable (mm)	Machined head	D.A.F.	Weight (gr.)
HI SEC	708077	110	M16	M12	± 5	Y	46	357
	708007	110	M16	M16	± 5	Y	46	514
	708094	130	M20	M20	± 5	N	46	775
	708079	110	M20	M16	± 10	Y	55	1095
	708029	160	M20	M20	± 10	Y	55	1011
	708005	160	M20	M20	± 10	N	55	1096
	708011	200	M24	M24	± 10	N	120	2234

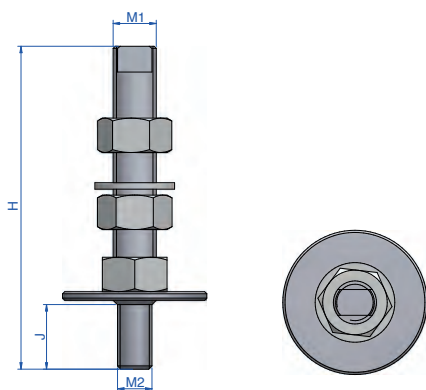

Standard height adjusters

Type	Code	H (mm)	M1	M2	J (mm)	Machined head	Weight (gr.)
STUD	708008	110	M16	M12	25	Y	215
	708003	110	M16	M16	-	Y	285
	708004	130	M20	M20	-	N	475
	708001	100	M12	M12	-	Y	174

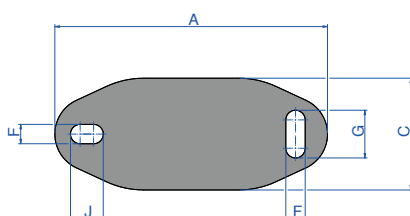

Shim

Type	Code	A (mm)	C (mm)	D (mm)	F (mm)	G (mm)	H (mm)	I (mm)	J (mm)	Weight (kg)
SMALL	136301	120	60	100	14	11	3	14	11	-
MEDIUM	136302	183	75	140	30	13	4	13	22	-
LARGE	136303	228	112	182	34	18	5	18	26	-

INSTALLATION PRINCIPLES

RECOMMENDATIONS FOR HOOD MOUNTS

The hood mounts should be installed between two parallel and perfectly flat surfaces. Mounts operating tilted or twisted do not work properly. This may be due to incorrect alignment, tolerances in the building of the chassis or over-tightened torque during the installation of the Antivibration mounts.

This applies to our marine-type, BSB, BRB or Mecanodamp mounts.

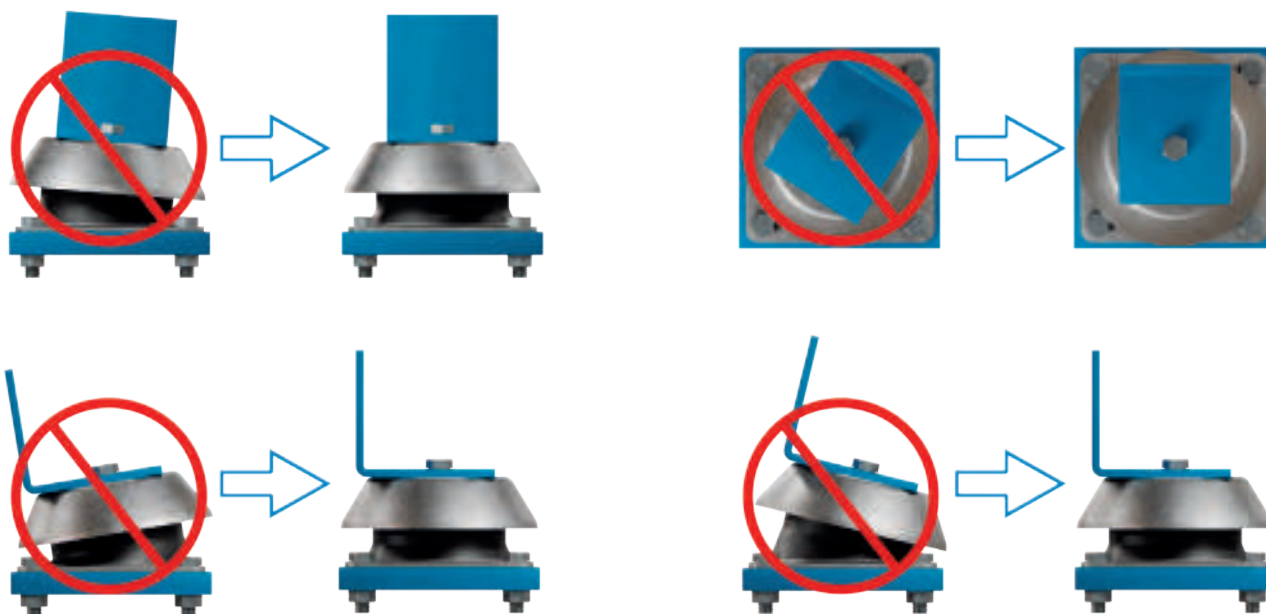

RECOMMENDATIONS FOR THE CONICAL MOUNTS

The conical mounts should always use the washers indicated for each model.

Similarly, we recommend the use of lateral limiters for cases with high loads or radial impact.

This applies to our AT, SCB, SCH or Mecanocaucho® mounts.

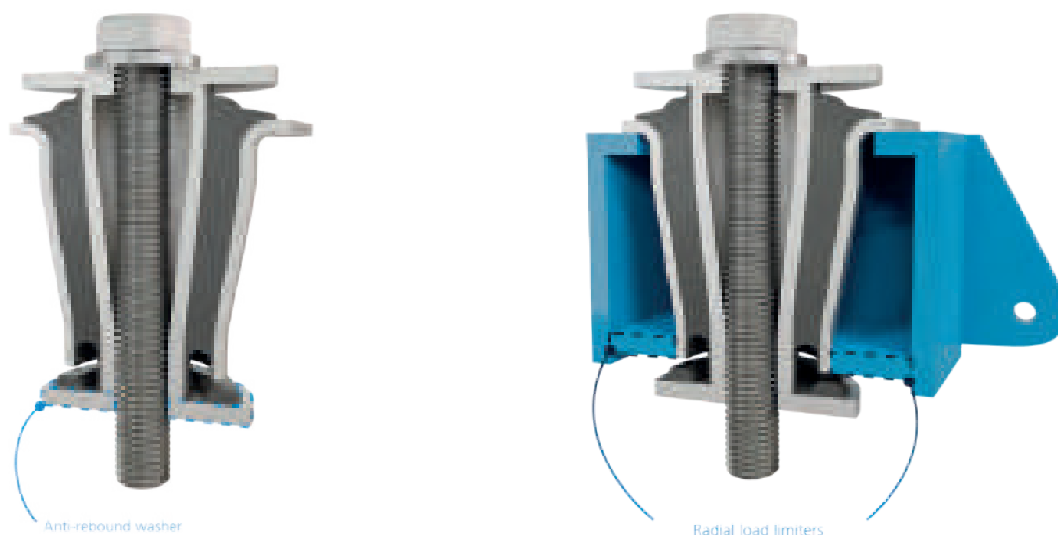

RECOMMENDATIONS FOR THE DSD AND DRD MOUNTS

Although it is not absolutely necessary, the AMC MECANOCAUCHO® hoods should be used in the DSD and DRD hoods. This hood distributes the load evenly in the event of overloads, and also provides protection from possible oil splashes.

Care should be taken to make sure that the protective hood has the same or a greater diameter than that of the diameter of the rubber element.

We have a standard range of Mecanocaucho® protection hoods. Check them out.



RECOMMENDATIONS FOR THE CYLINDRICAL MOUNTS

The cylindrical mounts should never work at traction. They should be used on a compression basis. To obtain greater deflection, use them at shear or shear /compression, although the maximum loads indicated in our catalogue for shear use should never be exceeded.

This applies to our bobbins, diablo, trapezoidal or annular mounts.



Compression

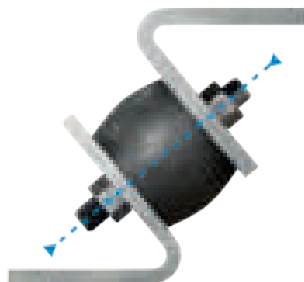

Compression-shear

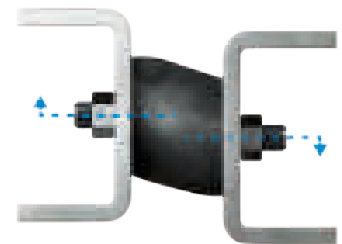

Shear

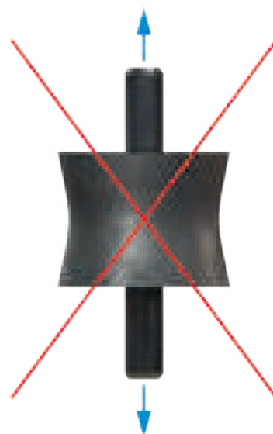

RECOMMENDATIONS FOR MACHINES THAT REQUIRE ALIGNMENT

When an alignment is required between different mechanical elements of the machine, the creeping effect should be taken into account. The increased deformation produced by the creep of the elastomer leads to a "misalignment" between suspended and rigid elements, particularly during the first 48 hours of static load in the antivibration mounts.

Alignment should therefore be checked 48 hours after the installation of the machine.

If this is not possible contact AMC's technical department and they will help you to ascertain the optimal alignment of your machine.

RECOMMENDATIONS FOR AMC MECANOCAUCHO® MACHINE MOUNTS WITHOUT ADJUSTABLE HOOD

On installing one of our AMC MECANOCAUCHO® machine mounts without adjustable hood, great care should be taken to ensure that the load of the machine does not rest on the screw, but on the hood.

This applies to our AMC MECANOCAUCHO® SV, SM and low SV series mounts.

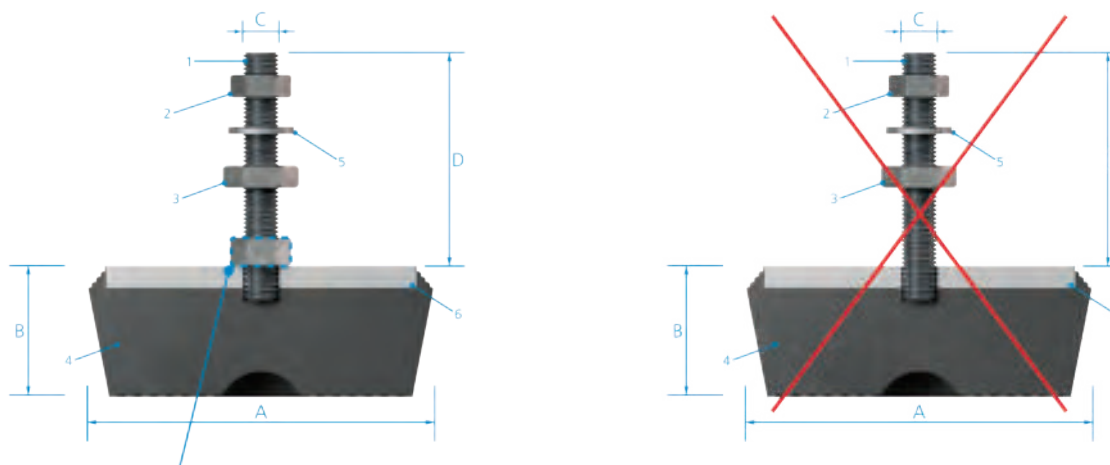

This nut spreads the load on the bell and avoids tensioning the below welded insert.

RECOMMENDATIONS FOR TORQUE TIGHTENING FOR THE BRB, BSB, MD AND MARINE MOUNTS

Before installing, make sure that the support surfaces are sufficiently rigid flat and totally parallel. The main fixing screw should be tightened according to the torques recommended in the following chart:

	M8	M10	M12	M16	M20	M24
Tightening torque Nm	16	32	55	125	190	285

RECOMMENDATIONS FOR THE INSTALLATION OF ANTIVIBRATION MOUNTS

The position of the antivibration mounts determines the vibration modes of the suspended ensemble. An even load distribution over all the mounts is advisable. One easy way of obtaining this is by installing the antivibration mounts equidistant from the CDG of the ensemble.

Mounts installed at the height of the crankshaft provide more stable suspensions and avoid over-movement of the suspended ensemble, particularly in mobile or moving applications.

The external connections to the suspended ensemble, such as cables, exhaust, hydraulic pipes, etc., must be elastic enough to prevent vibrations from being transmitted to the chassis through them.

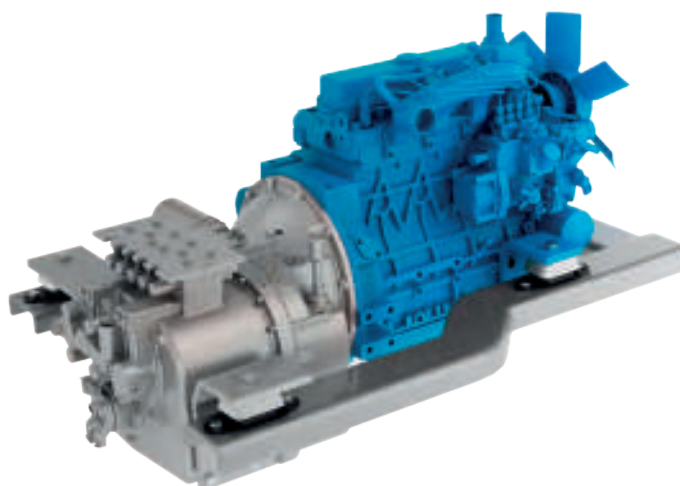

VIBRATION ISOLATOR PRO BLUETOOTH ACCELEROMETER

DESCRIPTION

AMC MECANOCAUCHO® Bluetooth Accelerometer has been developed to work in conjunction with the AMC MECANOCAUCHO® free of cost app Vibration Isolator Pro for Android and iOS.

This equipment can provide an immediate vibratory analysis in the frequency domain, by connecting it to an Android or iOS mobile phone or tablet.

The application will guide the user along several steps in order to complete the analysis in an easy way.

ADVANTAGES

- Compact design
- 3 axis accelerometer
- DC to 500Hz useful bandwidth
- Low noise
- iOS and Android compatible



QUICK GUIDE



SPECIFICATIONS

Acceleration Range	± 10g
Lower frequency limit	0Hz
Upper frequency limit	500Hz
Sensor technology	MEMS
Output Units	mm/s
Sampling rate	1024 kHz
Dimension	41 x 33 x 23 mm
Weigth	48 g
Housing material	Aluminium, plastic
Operating temperature range	-20 to 60°C
Residual Noise density	80 µg/√Hz rms
Sensitivity	19 µg/LSB
ADC resolution	20 Bits
Cross Axis sensitivity	1,50%
Maximum supported acc.	500g
Wireless protocol	Bluetooth LE 4.2

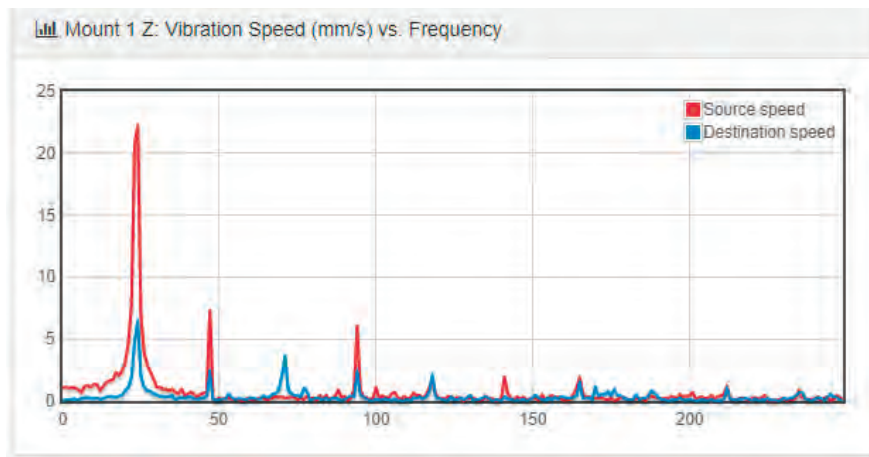

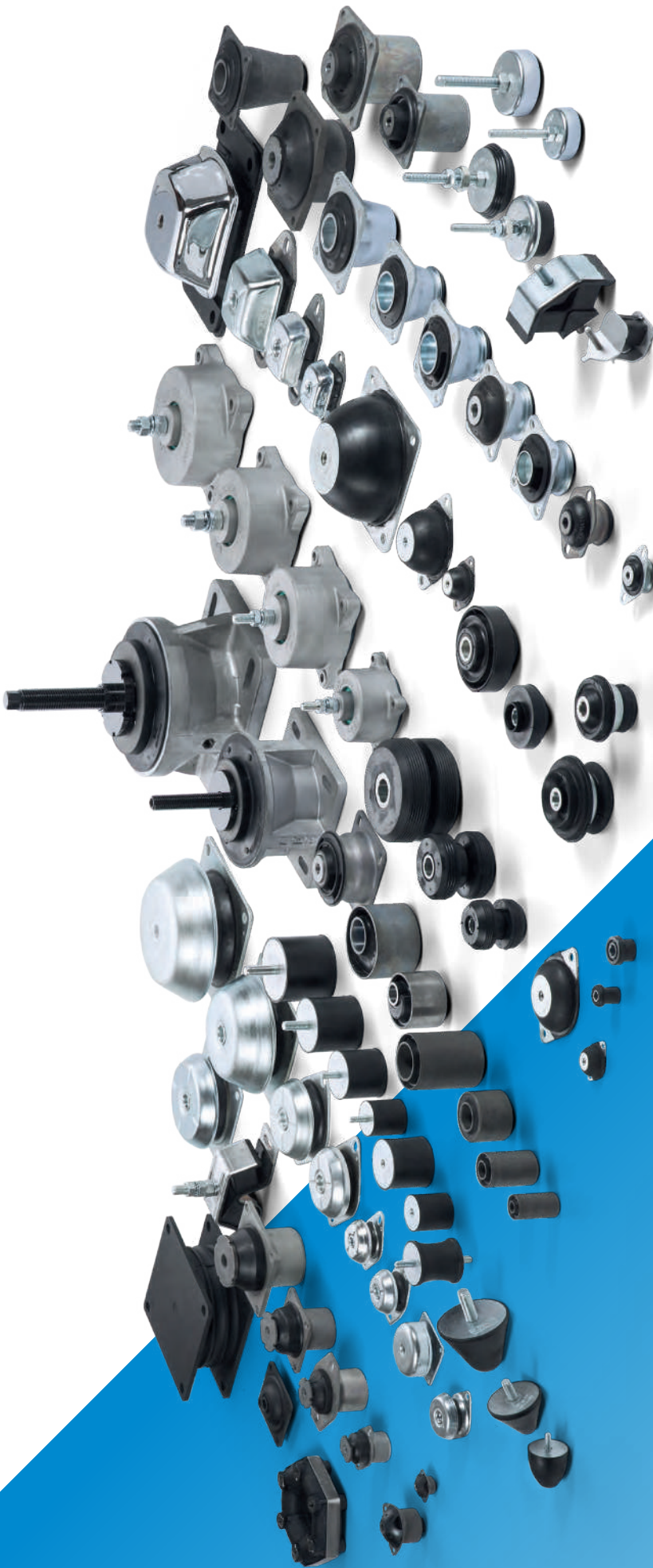

The following graph shows the expected vibration isolation performance when two key factors are known:

FREQUENCY OF EXCITATION

This is the problematic frequency which is required to be isolated. For example the vibration frequency produced from a diesel engine.

NATURAL FREQUENCY

This is the frequency at which a system will naturally oscillate at if subjected to an external force.

This frequency is dependant on the mass of the suspended element and the stiffness of the mounting points. If in doubt an AMC engineer is available to assist with calculations to determine the natural frequency of your installation.



Aplicaciones Mecánicas del Caucho S.A.
Industrialdea Parc 35 A. • E-20.159
ASTEASU (Gipuzkoa) España
Tel.: + 34 943 69 61 02 • Fax: + 34 943 69 62 19
e-mail: sales@amcsa.es
www.akustik.com
www.mecanocaucho.com